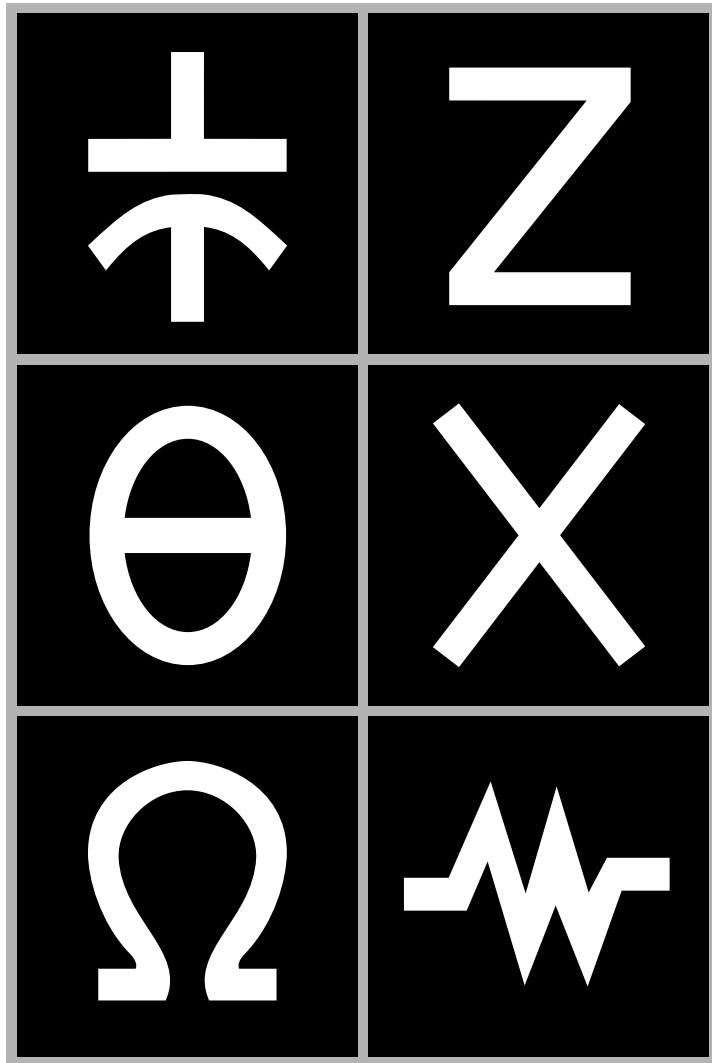


Agilent Technologies Impedance Measurement Handbook

December 2003



This page intentionally left blank.

The Impedance Measurement Handbook

A Guide to Measurement Technology and Techniques

Copyright® 2000-2003 Agilent Technologies Co. Ltd
All rights reserved.

TABLE OF CONTENTS

SECTION 1 Impedance measurement basics

Paragraph	1-1	Impedance	1-1
	1-2	Measuring impedance	1-3
	1-3	Parasitics: there are no pure R, C or L	1-3
	1-4	True, effective and indicated values	1-4
	1-5	Component dependency factors	1-5

SECTION 2 Impedance measurement instruments

Paragraph	2-1	Measurement methods	2-1
	2-2	Operating theory of practical instruments	2-5
		———— LF impedance measurement ————	
	2-3	Theory of auto balancing bridge method	2-5
	2-4	Key measurement functions	2-8
	2-4-1	OSC level	2-8
	2-4-2	DC bias	2-9
	2-4-3	Ranging function	2-10
	2-4-4	Level monitor function	2-11
	2-4-5	Measurement time and averaging	2-11
	2-4-6	Compensation function	2-12
	2-4-7	Guarding	2-13
	2-4-8	Grounded device measurement capability	2-14
		———— RF impedance measurement ————	
	2-5	Theory of RF I-V measurement method	2-16
	2-6	Difference between RF I-V and network analysis methods	2-18
	2-7	Key measurement functions	2-20
	2-7-1	OSC level	2-20
	2-7-2	Test port	2-20
	2-7-3	Calibration	2-21
	2-7-4	Compensation	2-21
	2-7-5	Measurement range	2-21
	2-7-6	DC bias	2-21

SECTION 3 Fixturing and cabling

	———— LF impedance measurement ————	
Paragraph	3-1 Terminal configuration	3-1
	3-2 Using test cables at high frequencies	3-5
	3-3 Test fixtures	3-5
	3-3-1 Agilent supplied test fixtures	3-5
	3-3-2 User fabricated test fixtures	3-6
	3-3-3 User test fixture example	3-7
	3-4 Test cables	3-8
	3-4-1 Agilent supplied test cables	3-8
	3-4-2 User fabricated test cable	3-8
	3-4-3 Test cable extension	3-9
	3-5 Eliminating the stray capacitance effects	3-12
	———— RF impedance measurement ————	
	3-6 Terminal configuration in RF region	3-12
	3-7 RF test fixtures	3-13
	3-7-1 Agilent supplied RF test fixtures	3-14
	3-8 Test port extension in RF region	3-15

SECTION 4 Measurement error and compensation

	———— Basic concepts and LF impedance measurement ————	
Paragraph	4-1 Measurement error	4-1
	4-2 Calibration and compensation	4-1
	4-2-1 Offset compensation	4-2
	4-2-2 Open and short compensations	4-2
	4-2-3 Precautions for open and short measurements	4-3
	4-2-4 Open, short and load compensations	4-4
	4-2-5 What should be used as the load?	4-5
	4-2-6 Application limit for open, short and load compensations	4-7
	4-3 Error caused by contact resistance	4-7
	4-4 Measurement cable extension induced error	4-9
	4-5 Practical compensation examples	4-11
	———— RF impedance measurement ————	
	4-6 Calibration and compensation in RF region	4-13
	4-6-1 Calibration	4-13
	4-6-2 Error source model	4-14
	4-6-3 Compensation method	4-15
	4-6-4 Precautions for open and short measurements in RF region	4-15
	4-6-5 Consideration for short compensation	4-16
	4-6-6 Calibrating load device	4-17
	4-6-7 Electrical length compensation	4-18
	4-6-8 Practical compensation technique	4-19
	4-7 Measurement correlation and repeatability	4-19

4-7-1	Variance in residual parameter value	4-19
4-7-2	A difference in contact condition	4-20
4-7-3	A difference in open and short compensation conditions	4-21
4-7-4	Electromagnetic coupling with a conductor near the DUT	4-21
4-7-5	Variance in environmental temperature	4-22

SECTION 5 Impedance measurement applications and enhancements

Paragraph 5-1	Capacitor measurement	5-1
5-2	Inductor measurement	5-5
5-3	Transformer measurement	5-9
5-4	Diode measurement	5-13
5-5	MOS FET measurement	5-14
5-6	Silicon wafer C-V measurement	5-15
5-7	High frequency impedance measurement using the probe	5-18
5-8	Resonator measurement	5-20
5-9	Cable measurements	5-23
5-10	Balanced device measurement	5-25
5-11	Battery measurement	5-27
5-12	Test signal voltage enhancement	5-28
5-13	DC bias voltage enhancement	5-30
5-14	DC bias current enhancement	5-32
5-15	Equivalent circuit analysis function and its application	5-34

APPENDIX A	The concept of a test fixture's additional error	A-1
------------	--	-----

APPENDIX B	Open and short compensation	B-1
------------	-----------------------------------	-----

APPENDIX C	Open, short and load compensation	C-1
------------	---	-----

APPENDIX D	Electrical length compensation	D-1
------------	--------------------------------------	-----

APPENDIX E	Q measurement accuracy calculation	E-1
------------	--	-----

Authors:

Kazunari Okada

Toshimasa Sekino

Agilent Technologies Co. Ltd

This page intentionally left blank.

SECTION 1

Impedance measurement basics

1-1. Impedance

Impedance is an important parameter used to characterize electronic circuits, components, and the materials used to make components. Impedance (Z) is generally defined as the total opposition a device or circuit offers to the flow of an alternating current (AC) at a given frequency, and is represented as a complex quantity which is graphically shown on a vector plane. An impedance vector consists of a real part (resistance, R) and an imaginary part (reactance, X) as shown in Figure 1-1. Impedance can be expressed using the rectangular-coordinate form $R+jX$ or in the polar form as a magnitude and phase angle: $|Z| \angle \theta$. Figure 1 also shows the mathematical relationship between R , X , $|Z|$ and θ . In some cases, using the reciprocal of impedance is mathematically expedient. In which case $1/Z = 1/(R+jX) = Y = G+jB$, where Y represents admittance, G conductance, and B susceptance. The unit of impedance is the ohm (Ω), and admittance is the siemen (S). Impedance is a commonly used parameter and is especially useful for representing a series connection of resistance and reactance, because it can be expressed simply as a sum, R and X . For a parallel connection, it is better to use admittance (see Figure 1-2).

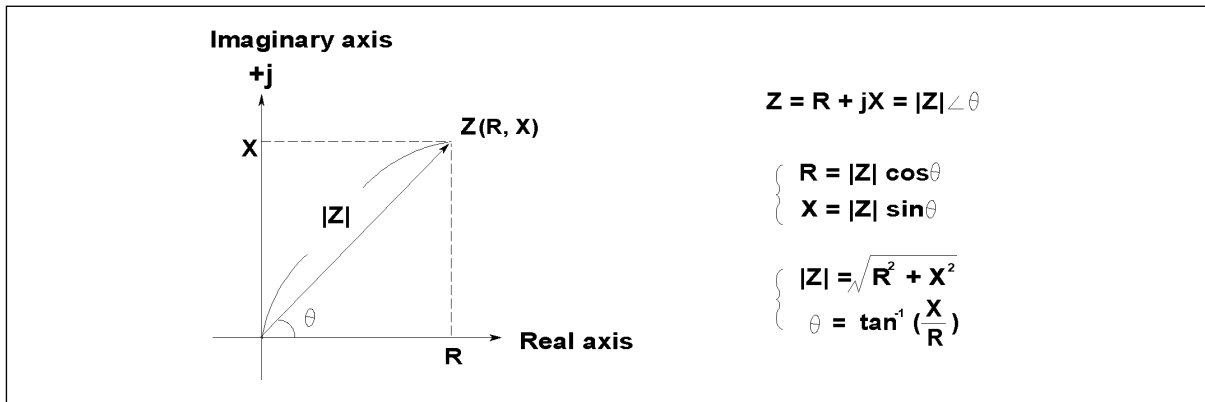


Figure 1-1. Impedance (Z) consists of a real part (R) and an imaginary part (X)

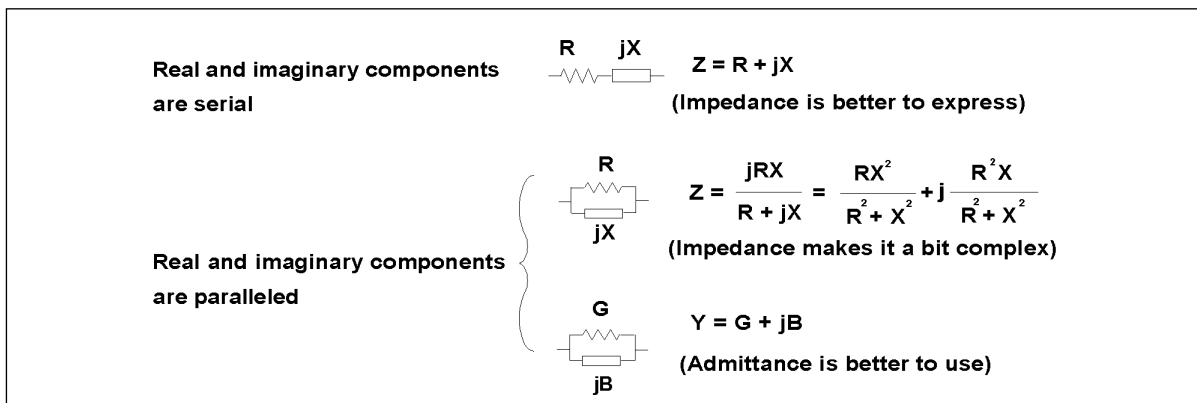


Figure 1-2. Expression of series and parallel combination of real and imaginary components

Reactance takes two forms - inductive (X_L) and capacitive (X_C). By definition, $X_L=2\pi fL$ and $X_C=1/(2\pi fC)$, where f is the frequency of interest, L is inductance, and C is capacitance. $2\pi f$ can be substituted for by the angular frequency (ω :omega) to represent $X_L=\omega L$ and $X_C=1/(\omega C)$. Refer to Figure 1-3.

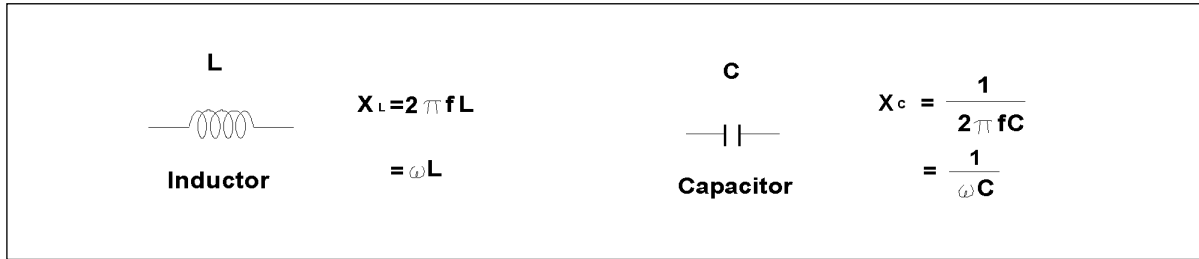


Figure 1-3. Reactance in two forms - inductive (X_L) and capacitive (X_C)

A similar reciprocal relationship applies to susceptance and admittance. Figure 1-4 shows a typical representation for a resistance and a reactance connected in series or in parallel.

The quality factor (Q) serves as a measure of a reactance's purity (how close it is to being a pure reactance, no resistance), and is defined as the ratio of the energy stored in a component to the energy dissipated by the component. Q is a dimensionless unit and is expressed as $Q=X/R=B/G$. From Figure 1-4, you can see that Q is the tangent of the angle θ . Q is commonly applied to inductors; for capacitors the term more often used to express purity is dissipation factor (D). This quantity is simply the reciprocal of Q , it is the tangent of the complementary angle of θ , the angle δ shown in Figure 1-4 (d).

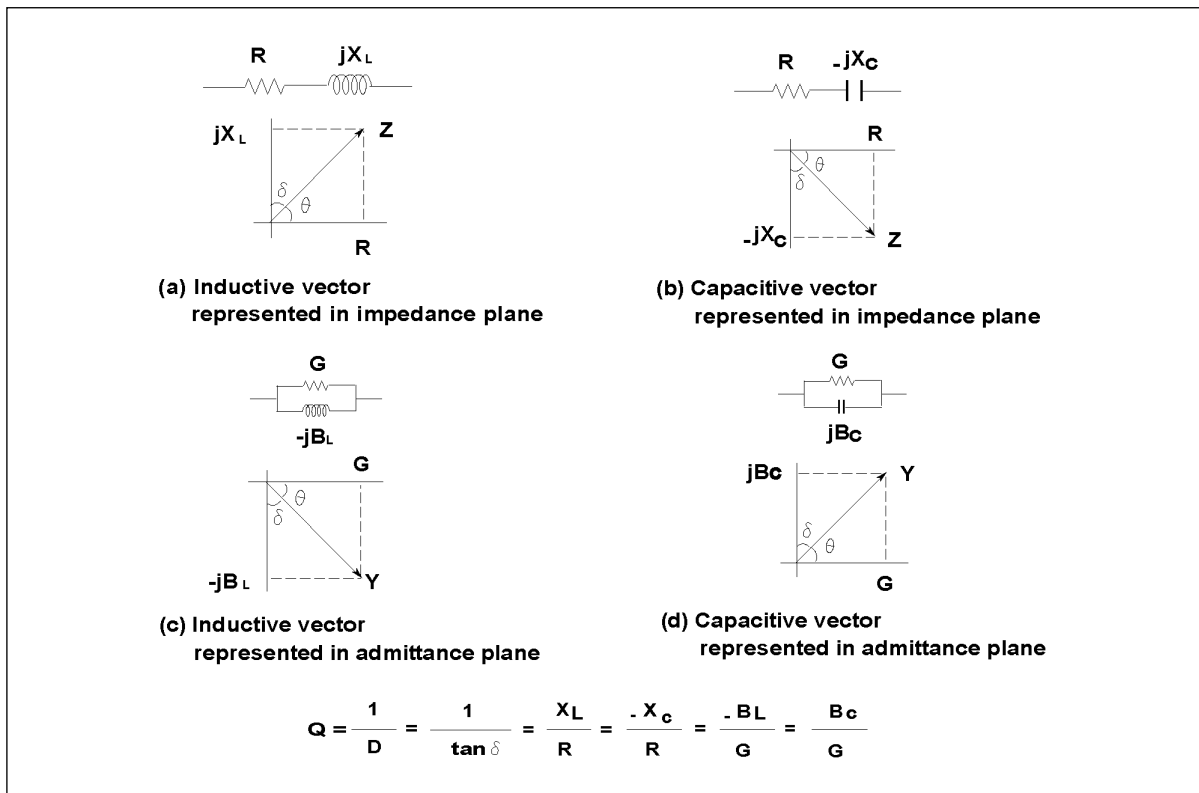


Figure 1-4. Relationships between impedance and admittance parameters

1-2. Measuring impedance

To find the impedance, we need to measure at least two values because impedance is a complex quantity. Many modern impedance measuring instruments measure the real and the imaginary parts of an impedance vector and then convert them into the desired parameters such as $|Z|$, θ , $|Y|$, R , X , G , B . It is only necessary to connect the unknown component, circuit, or material to the instrument. However, sometimes the instrument will display an unexpected result (too high or too low). One possible cause of this problem is incorrect measurement technique, or the natural behavior of the unknown device. In this section, we will focus on the traditional passive components and discuss their natural behavior in the real-world as compared to their idealistic behavior.

1-3. Parasitics: There are no pure R, C or L

All circuit components are neither purely resistive nor purely reactive, they are a combination of these impedance elements. The result is, all real-world devices have parasitics - unwanted inductance in resistors, unwanted resistance in capacitors, unwanted capacitance in inductors, etc. Of course, different materials and manufacturing technologies produce varying amounts of parasitics, affecting both a component's usefulness and the accuracy with which you can determine its resistance, capacitance, or inductance. A real-world component contains many parasitics. With the combination of a component's primary element and parasitics, a component will be like a complex circuit, if it is represented by electrical symbols as shown in Figure 1-5.

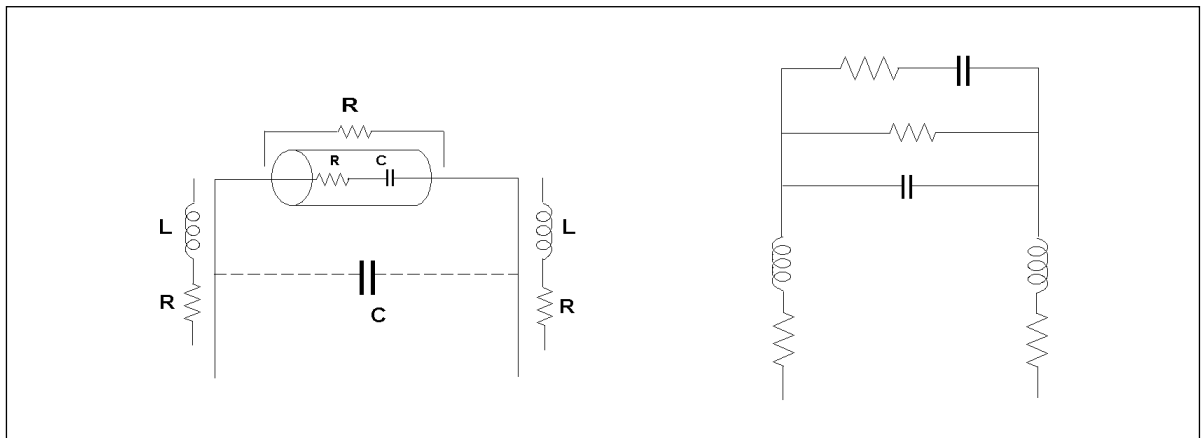


Figure 1-5. Component (capacitor) with parasitics represented by an electrical equivalent circuit

1-4. True, effective, and indicated values

A thorough understanding of true, effective, and indicated values of a component, as well as their significance to component measurements, is essential before you proceed with making practical measurements.

- A *true* value is the value of a circuit component (resistor, inductor or capacitor) that excludes the defects of its parasitics. In many cases, the true value can be defined by a mathematical relationship involving the component's physical composition. In the real-world, true values are only of academic interest (Figure 1-6 (a)).
- The *effective* value takes into consideration the effects of a component's parasitics. The effective value is the algebraic sum of the circuit component's real and reactive vectors; thus, it is frequency dependent (Figure 1-6 (b)).
- The *indicated* value is the value obtained with and displayed by the measurement instrument; it reflects the instrument's inherent losses and inaccuracies. Indicated values always contain errors when compared to true or effective values. They also vary intrinsically from one measurement to another; their differences depend on a multitude of considerations. Comparing how closely an indicated value agrees with the effective value under a defined set of measurement conditions lets you judge the measurement's quality (Figure 1-6 (c)).

The effective value is what we want to know, and the goal of measurement is to have the indicated value to be as close as possible to the effective value.

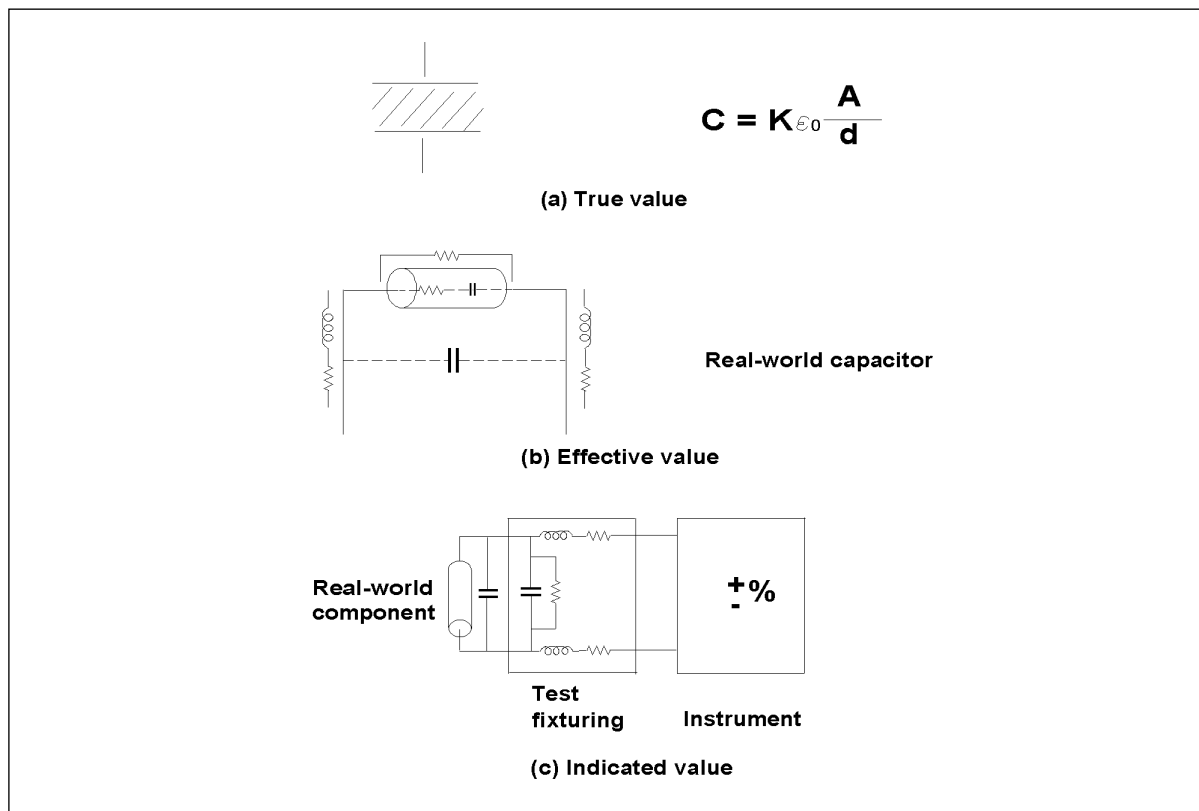


Figure 1-6. True, effective, and indicated values

1-5. Component dependency factors

The measured impedance value of a component depends on several measurement conditions, such as frequency, test signal level, and so on. Effects of these component dependency factors are different for different types of materials used in the component, and by the manufacturing process used. The following are typical dependency factors that affect measurement results.

Frequency:

Frequency dependency is common to all real-world components because of the existence of parasitics. Not all parasitics affect the measurement, but some prominent parasitics determine the component's frequency characteristics. The prominent parasitics will be different when the impedance value of the primary element is not the same. Figures 1-7 through 1-9 shows the typical frequency response for real-world resistors, inductors, and capacitors.

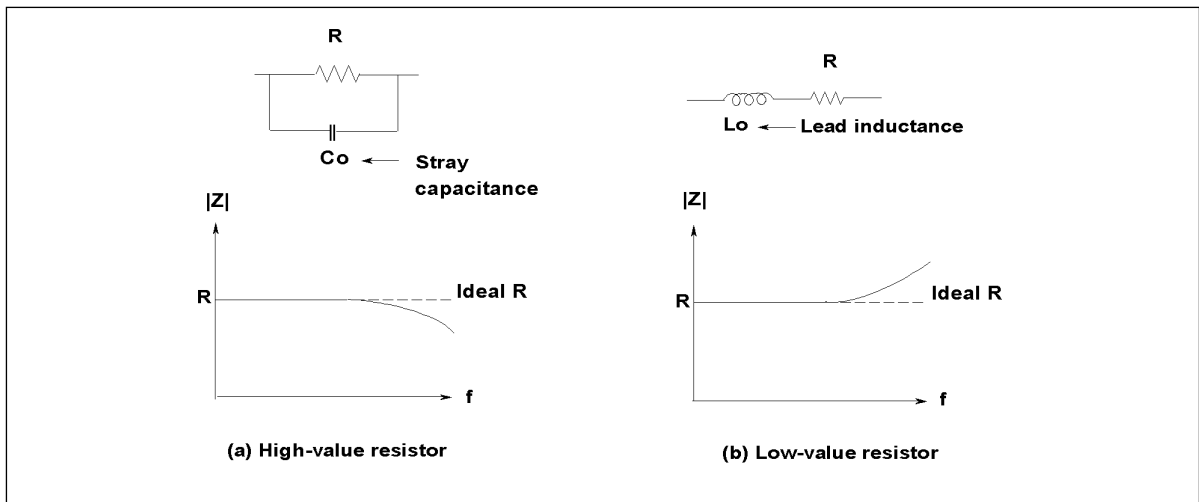


Figure 1-7. Resistor frequency response

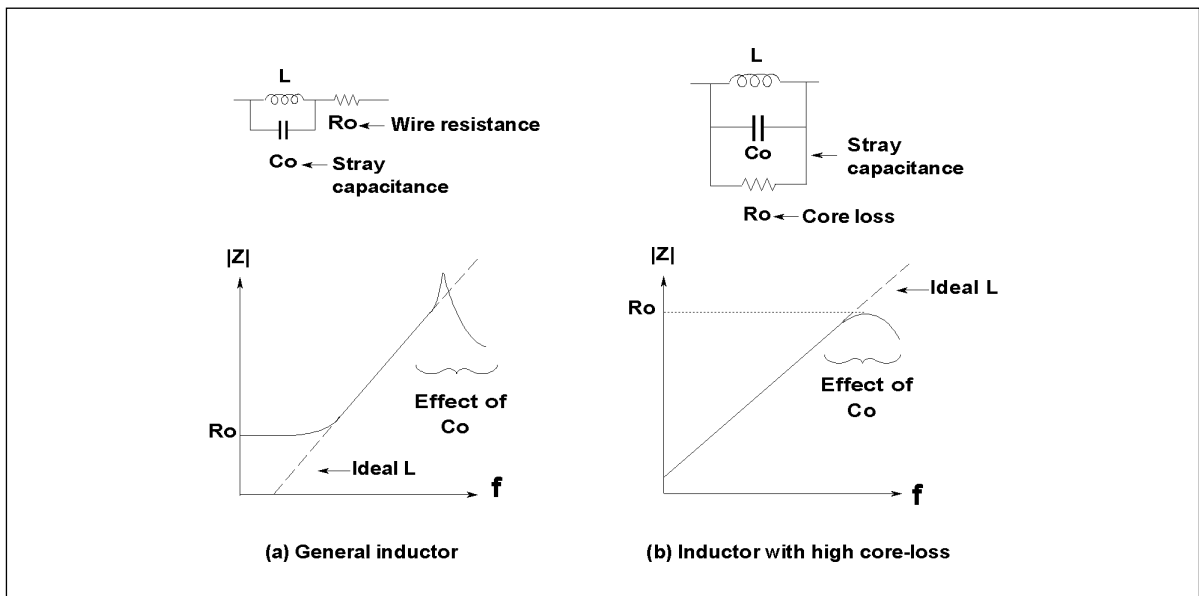


Figure 1-8. Inductor frequency response

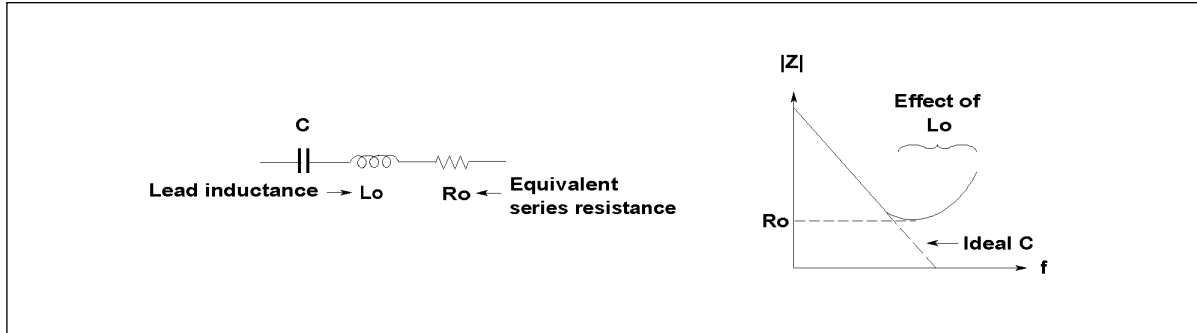


Figure 1-9. Capacitor frequency response

Test signal level:

The test signal (AC) applied may affect the measurement result for some components. For example, ceramic capacitors are test signal voltage dependent as shown in Figure 1-10 (a). This dependency varies depending on the dielectric constant (K) of the material used to make the ceramic capacitor.

Cored-inductors are test signal current dependent due to the electromagnetic hysteresis of the core material. Typical AC current characteristics are shown in Figure 1-10 (b).

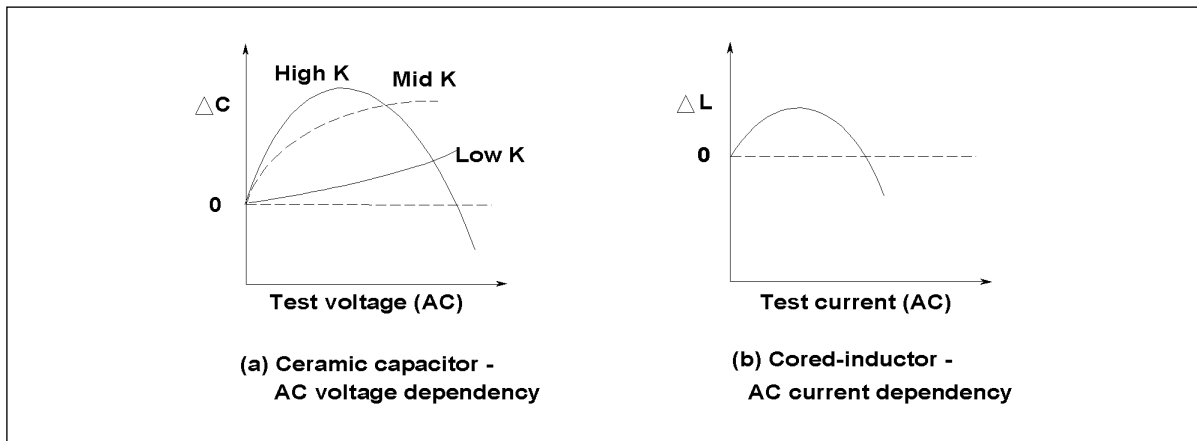


Figure 1-10. Test signal level (AC) dependencies of ceramic capacitors and cored-inductors

DC bias:

DC bias dependency is very common in semiconductor components such as diodes and transistors. Some passive components are also DC bias dependent. The capacitance of a high-K type dielectric ceramic capacitor will vary depending on the DC bias voltage applied, as shown in Figure 1-11 (a).

In the case of cored-inductors, the inductance varies according to the DC bias current flowing through the coil. This is due to the magnetic flux saturation characteristics of the core material. Refer to Figure 11 (b).

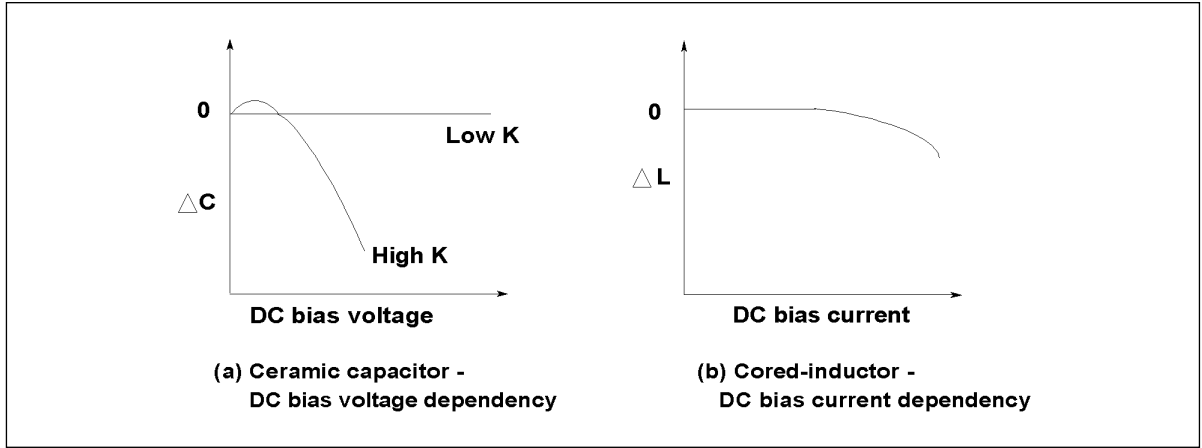


Figure 1-11. DC bias dependencies of ceramic capacitors and cored-inductors

Temperature:

Most types of components are temperature dependent. The temperature coefficient is an important specification for resistors, inductors and capacitors. Figure 1-12 shows some typical temperature dependencies that affect ceramic capacitors with different dielectrics.

Other dependency factors:

Other physical and electrical environments, e.g., humidity, magnetic fields, light, atmosphere, vibration, and time may change the impedance value. For example, the capacitance of a high-K type dielectric ceramic capacitors decreases with age as shown in Figure 1-13.

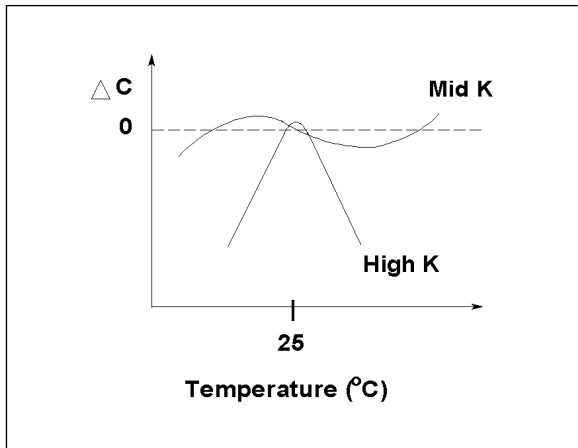


Figure 1-12. Temperature dependency of ceramic capacitors

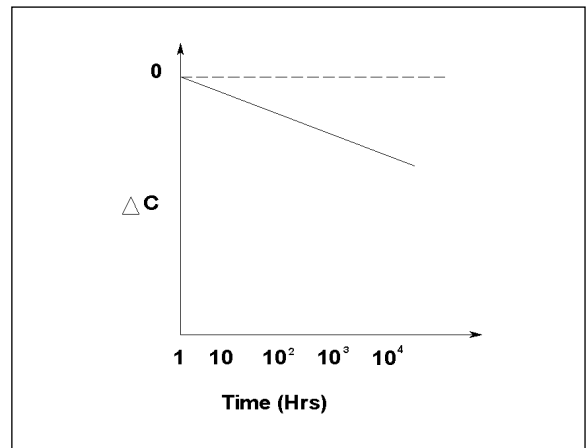


Figure 1-13. Aging dependency of ceramic capacitors

This page intentionally left blank.

SECTION 2

Impedance measurement instruments

2-1. Measurement methods

There are many measurement methods to choose from when measuring impedance, each of which has advantages and disadvantages. You must consider your measurement requirements and conditions, and then choose the most appropriate method, while considering such factors as frequency coverage, measurement range, measurement accuracy, and ease of operation. Your choice will require you to make tradeoffs as there is not a single measurement method that includes all measurement capabilities. Figure 2-1 shows six commonly used impedance measurement methods, from low frequencies up to the microwave region. Table 2-1 lists the advantages and disadvantages of each measurement method, the corresponding Agilent typical instruments, their applicable frequency range, and the typical applications for each method. Considering only measurement accuracy and ease of operation, the auto balancing bridge method is the best choice for measurements up to 110 MHz. For measurements from 100 MHz to 3 GHz, the RF I-V method has the best measurement capability, and from 3 GHz and up the network analysis is the recommended technique.

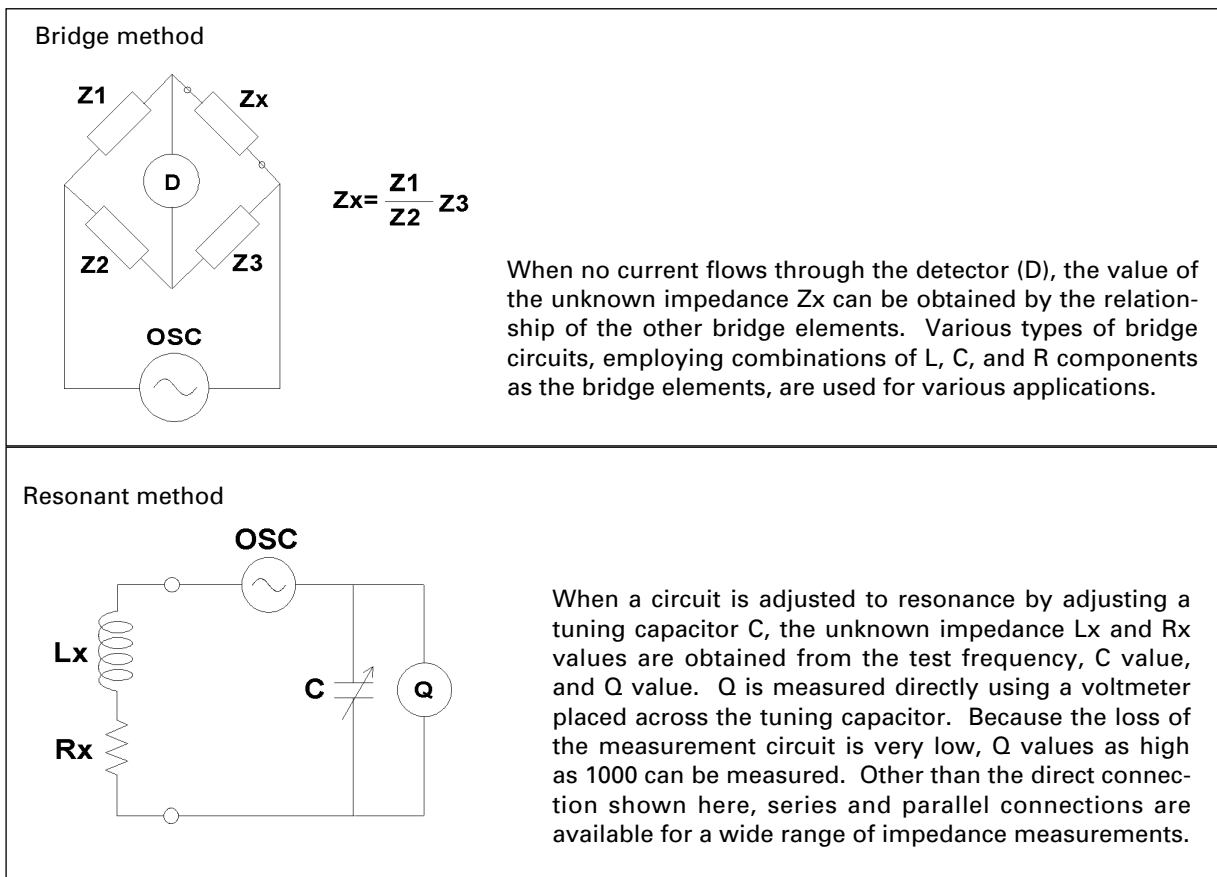
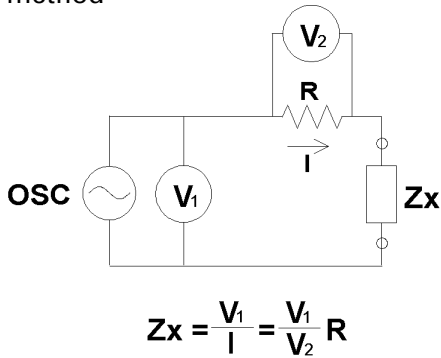


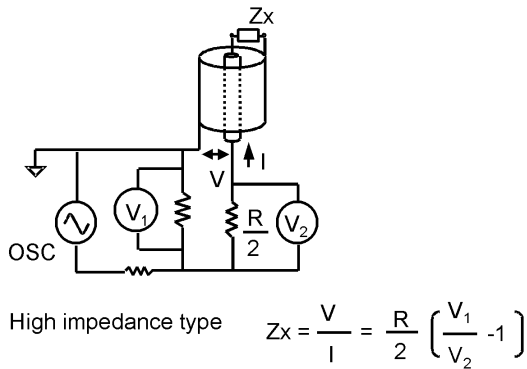
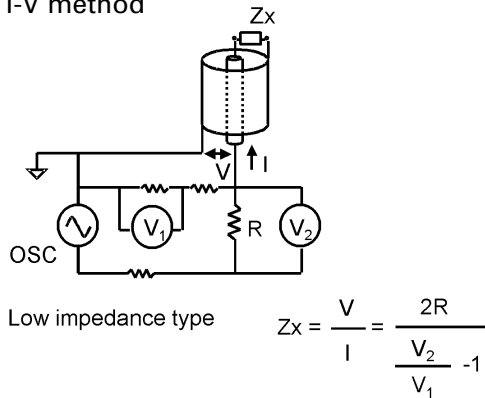
Figure 2-1. Impedance measurement method (1 of 3)

I-V method



An unknown impedance Z_x can be calculated from measured voltage and current values. Current is calculated using the voltage measurement across an accurately known low value resistor, R . In practice a low-loss transformer is used in place of R to prevent the effects caused by placing a low value resistor in the circuit. The transformer, however, limits the low end of the applicable frequency range.

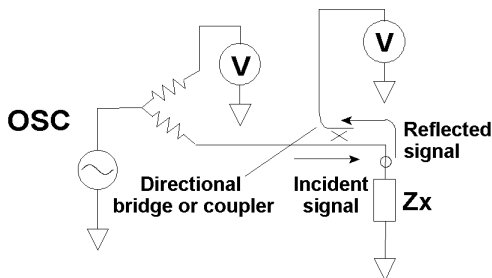
RF I-V method



While the RF I-V measurement method is based on the same principle as the I-V method, it is configured in a different way by using an impedance matched measurement circuit (50Ω) and a precision coaxial test port for operation at higher frequencies. There are two types of the voltmeter and current meter arrangements; which are suited to low impedance and high impedance measurements.

Impedance of the device under test (DUT) is derived from measured voltage and current values, as illustrated. The current that flows through the DUT is calculated from the voltage measurement across a known low value resistor, R . In practice, a low loss transformer is used in place of the low value resistor, R . The transformer limits the low end of the applicable frequency range.

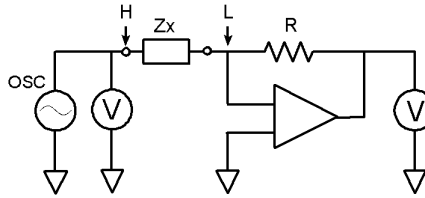
Network analysis method



The reflection coefficient is obtained by measuring the ratio of an incident signal to the reflected signal. A directional coupler or bridge is used to detect the reflected signal and a network analyzer is used to supply and measure the signals. Since this method measures reflection at the DUT, it is usable in the higher frequency range.

Figure 2-1. Impedance measurement method (2 of 3)

Auto balancing bridge method



The current, flowing through the DUT, also flows through resistor R . The potential at the "L" point is maintained at zero volts (thus called a "virtual ground"), because the current through R balances with the DUT current by operation of the I-V converter amplifier. The DUT impedance is calculated using voltage measurement at High terminal and that across R .

Note: In practice, the configuration of the auto balancing bridge differs for each type of instrument.

Generally LCR meters, in a low frequency range typically below 100 kHz, employ a simple operational amplifier for its I-V converter. This type of instrument has a disadvantage in accuracy, at high frequencies, because of performance limits of the amplifier. Wideband LCR meters and impedance analyzers employ the I-V converter consisting of sophisticated null detector, phase detector, integrator (loop filter) and vector modulator to ensure a high accuracy for a broad frequency range over 1 MHz. This type of instrument can attain to a maximum frequency of 110 MHz.

Figure 2-1. Impedance measurement method (3 of 3)

Table 2-1. Common impedance measurement methods

	Advantages	Disadvantages	Applicable frequency range	Typical Agilent products	Common application
Bridge method	High accuracy (0.1%typ.). Wide frequency coverage by using different types of bridges. Low cost.	Need to be manually balanced. Narrow frequency coverage with a single instrument.	DC to 300 MHz	None	Standard lab
Resonant method	Good Q accuracy up to high Q.	Need to be tuned to resonance. Low impedance measurement accuracy.	10 kHz to 70 MHz	None	High Q device measurement.
I-V method	Grounded device measurement. Suitable to probe type test needs.	Operating frequency range is limited by transformer used in probe.	10 kHz to 100 MHz	None	Grounded device measurement.
RF I-V method	High accuracy (1% typ.) and wide impedance range at high frequencies.	Operating frequency range is limited by transformer used in test head.	1 MHz to 3 GHz	4287A 4395A+43961A 4396B+43961A E4991A	RF component measurement.
Network analysis method	High frequency Range. Good accuracy when the unknown impedance is close to the characteristic impedance	Recalibration required when the measurement frequency is changed. Narrow impedance measurement range.	300 kHz and above	8753E 4395A	RF component measurement.
Auto balancing bridge method	Wide frequency coverage from LF to HF. High accuracy over a wide impedance measurement range. Grounded device measurement	Higher frequency ranges not available.	20 Hz to 110 MHz	4284A 4294A 4294A+42941A (*1) 4294A+42942A (*1)	Generic component measurement (*1) Grounded device measurement

Note: Agilent Technologies currently offers no instruments for the bridge method and the resonant method shaded in the above table.

2-2. Operating theory of practical instruments

The operating theory and key functions of the auto balancing bridge instrument are discussed in the paragraphs 2-3 through 2-4-8. A discussion of the RF I-V instrument is described in paragraphs 2-5 through 2-7-6.

2-3. Theory of auto balancing bridge method

The auto balancing bridge method is commonly used in modern LF impedance measurement instruments. Its operational frequency range has been extended up to 110 MHz. A detailed discussion of the operating theory of a practical instrument using Agilent 4294A precision impedance analyzer as an example will now be discussed. Table 2-2 lists the 4294A's key specifications, and Figure 2-2 shows the simplified block diagram of the 4294A analog section.

Table 2-2. Agilent 4294A precision impedance analyzer key specifications

Test signal	Frequency: 40 Hz to 110 MHz, 1 mHz resolution Signal level: 5 mV to 1 V rms
Impedance measurement parameters	$ Z $, $ Y $, θ , R, X, G, B, L, C, D, Q
Impedance measurement range	3 m Ω to 500 M Ω
Basic measurement accuracy	0.08% of reading
Display	Color graphic display, 6 digits
DC bias	0 V to ± 40 V, 0 mA to ± 100 mA

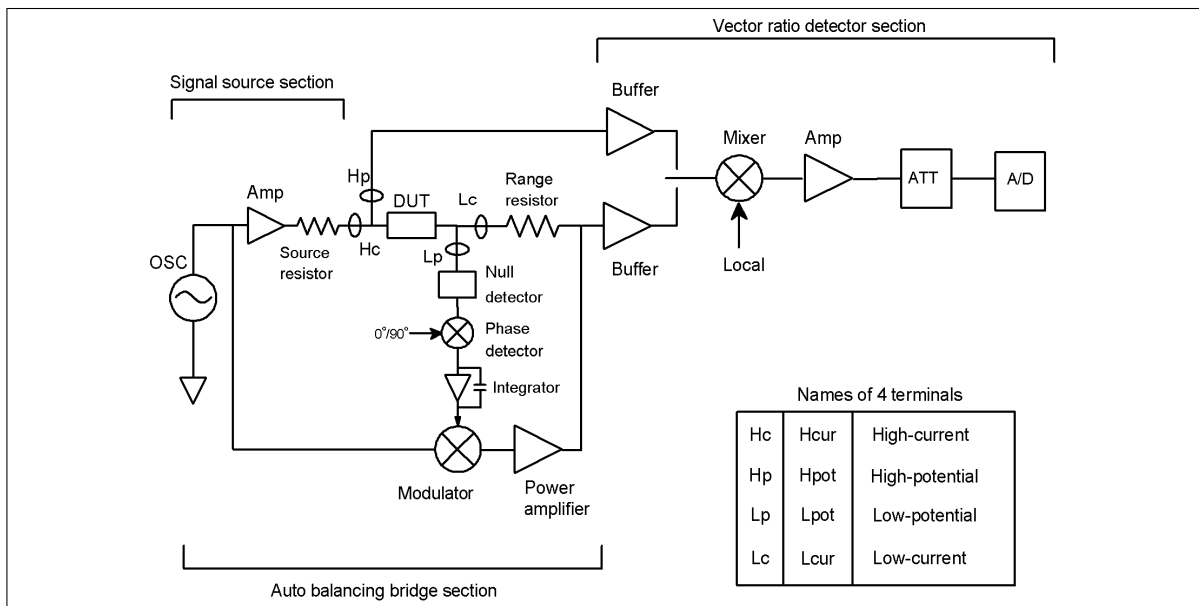


Figure 2-2. Simplified analog-section block diagram for the Agilent 4294A precision impedance analyzer

The measurement circuit is functionally divided into following three sections.

The **signal source section** generates the test signal applied to the unknown device. The frequency of the test signal (f_m) is variable from 40 Hz to 110 MHz, and the maximum frequency resolution is 1 mHz. A microprocessor controlled frequency synthesizer is employed to generate these high-resolution test signals. The output signal level, variable from 5 mV to 1 V, is adjusted using an attenuator. Figure 2-3 shows a diagram of the signal source section. In addition to generating the test signal which is fed to the DUT, the internally used reference signals are also generated in this section.

The **auto balancing bridge section** balances the range resistor current with the DUT current to maintain a zero potential at the low terminal. Figure 2-4 (a) shows a simplified block diagram of the bridge section. The detector D detects potential at the low terminal and controls both magnitude and phase of the OSC2 output, so that the detected potential becomes zero. The actual balancing operation is shown in Figure 2-4 (b). When the bridge is “unbalanced”, the null detector detects an error current and the phase detectors, at the next stage, separate it into 0° and 90° vector components. The output signals of the phase detectors go through loop filters (integrators) and are applied to the modulator to drive the 0° and 90° component signals. The resultant signal is amplified and fed back through range resistor R_r to cancel the current through the DUT, therefore no error current flows into the null detector. This balancing operation is performed automatically over the full frequency range of 40 Hz to 110 MHz.

The **vector ratio detector section** measures two vector voltages across the DUT (E_{dut}) and range resistor R_r (E_{rr}) series circuit (Figure 2-5). Since the range resistor value is known, measuring two voltages will give the impedance vector Z_x of the DUT by $Z_x = R_r \times (E_{dut}/E_{rr})$. Selector S1 selects either the E_{dut} or E_{rr} signal so that these signals alternately flow identical paths to eliminate tracking errors between the two signals. Each vector voltage is measured using an A to D converter and separated into its 0° and 90° components by digital processing.

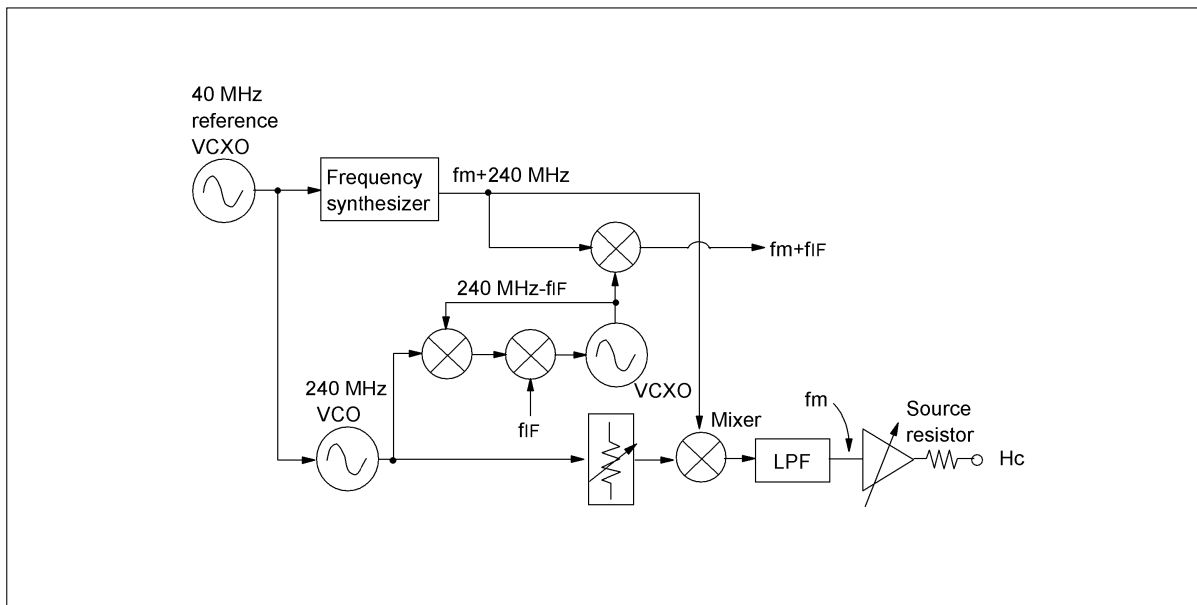


Figure 2-3. Signal source section block diagram

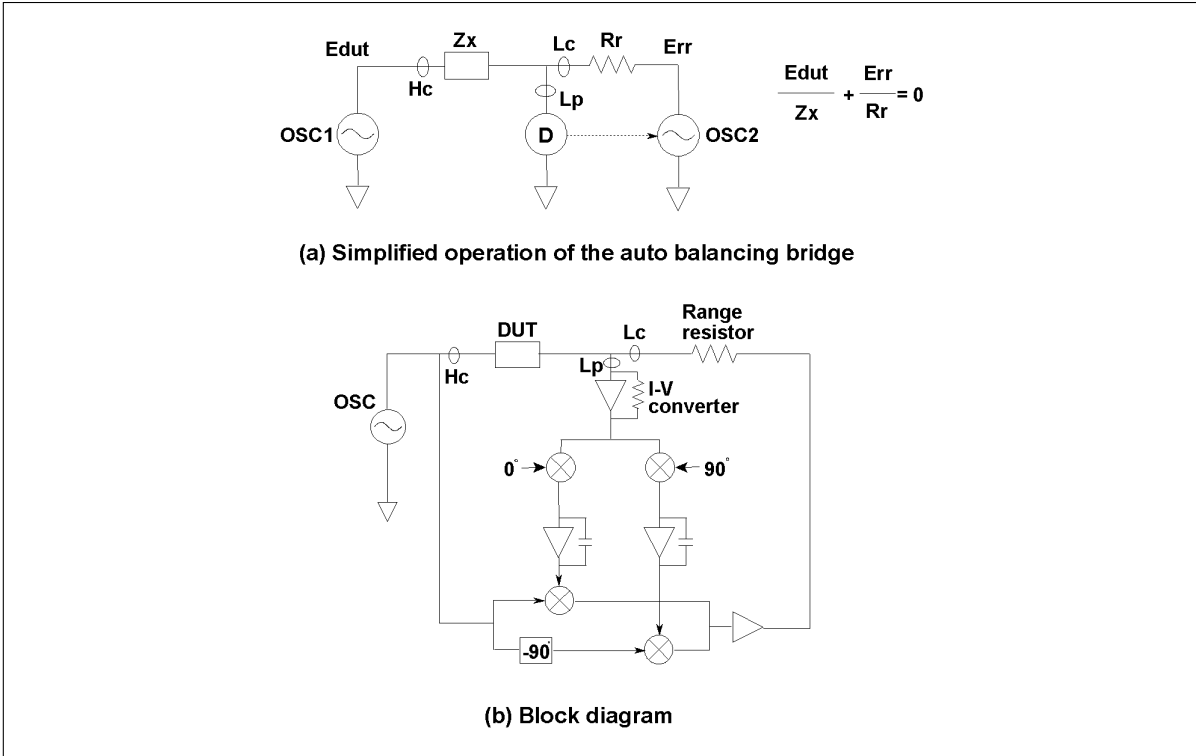


Figure 2-4. Auto balancing bridge section block diagram

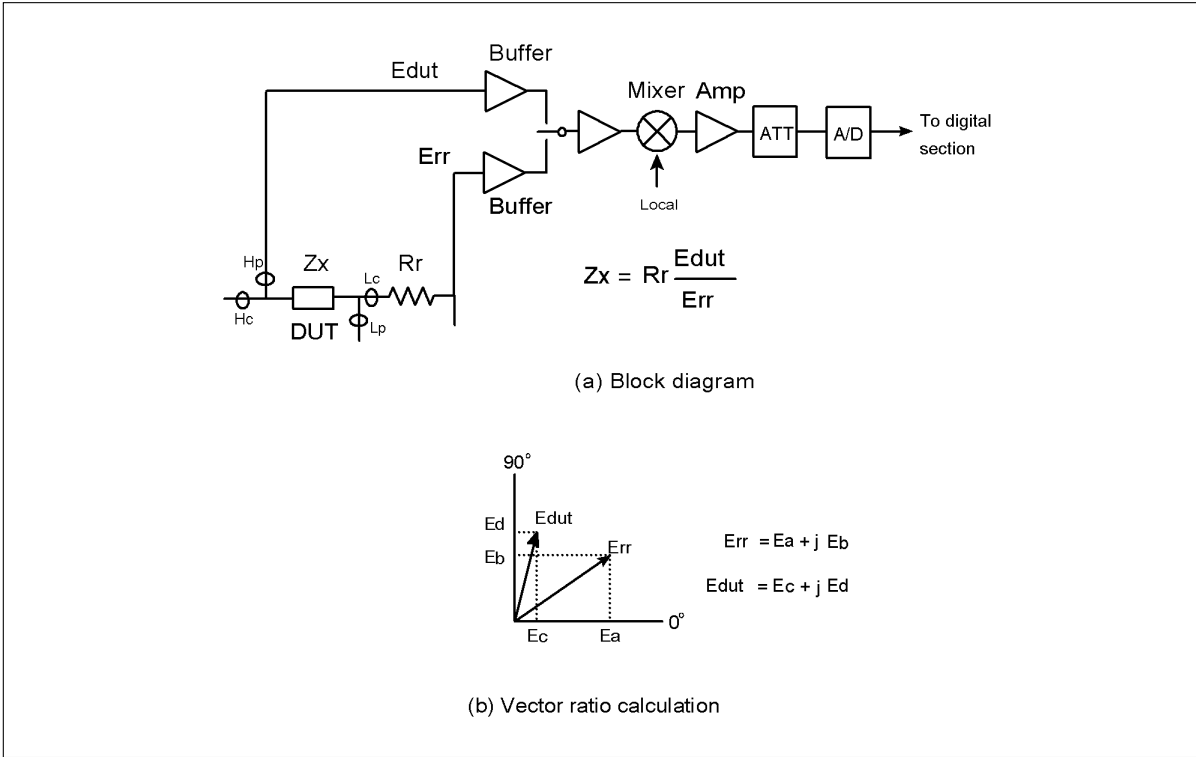


Figure 2-5. Vector ratio detector section block diagram

2-4. Key measurement functions

The following discussion describes the key measurement functions for advanced impedance measurement instruments. Thoroughly understanding these measurement functions will eliminate the confusion sometimes caused by the measurement results obtained.

2-4-1. OSC level

The oscillator output signal is output through the Hc terminal and can be varied to change the test signal level applied to the DUT. The specified output signal level, however, is not always applied directly to the DUT. In general, the specified OSC level is obtained when the High terminal is open. Since source resistor R_s is connected in series with the oscillator output, as shown in Figure 2-6, there is a voltage drop across R_s . So, when the DUT is connected, the applied voltage V_x depends on the value of the Source resistor and the DUT's impedance value, Z_x . This must be taken into consideration especially when measuring low values of impedance (low inductance or high capacitance). The OSC level should be set as high as possible to obtain a good S/N ratio for the vector ratio detector section. A high S/N ratio improves the accuracy and stability of the measurement. In some cases, however, the OSC level should be decreased, such as when measuring core-inductors, and when measuring semiconductor devices in which the OSC level is critical for the measurement and to the device itself.

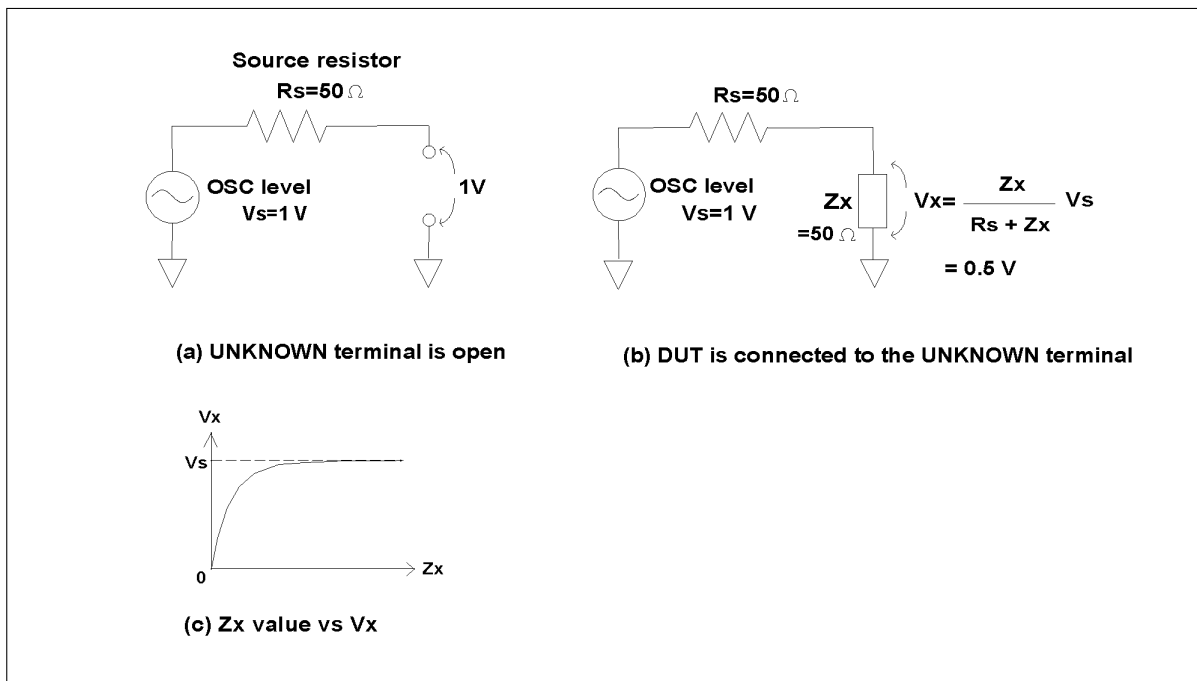


Figure 2-6. OSC level divided by source resistor (R_s) and DUT impedance (Z_x)

2-4-2. DC bias

In addition to the AC test signal, a DC voltage can be output through the Hc terminal and applied to the DUT. A simplified output circuit, with a DC bias source, is shown in Figure 2-7. Many of the conventional impedance measurement instruments have a voltage bias function, which assumes that almost no bias current flows (the DUT has a high resistance). If the DUT's DC resistance is low, a bias current flows through the DUT and into the range resistor R_r , thereby raising the DC potential of the virtual ground point. Also the bias voltage is dropped at source resistor R_s . As a result, the specified bias voltage is not applied to the DUT and, in some cases, it may cause measurement error. This must be taken into consideration when a low resistivity semiconductor device is measured.

The Agilent 4294A (and some other impedance analyzers) has advanced DC bias function that can be set to either voltage source mode or current source mode. Because the bias output is automatically regulated according to the monitored bias voltage and current, the actual bias voltage or current applied across the DUT is always maintained at the setting value regardless of the DUT's DC resistance. The bias voltage or current can be regulated when the output is within the specified compliance range.

Inductors are conductive at DC. Often a DC current dependency of inductance needs to be measured. Generally the internal bias output current is not enough to bias the inductor at the required current levels. To apply a high DC bias current to the DUT, an external current bias unit or adapter can be used with specific instruments. The 42841A and its bias accessories are available for high current bias measurements using the 4284A and 4285A precision LCR meters.

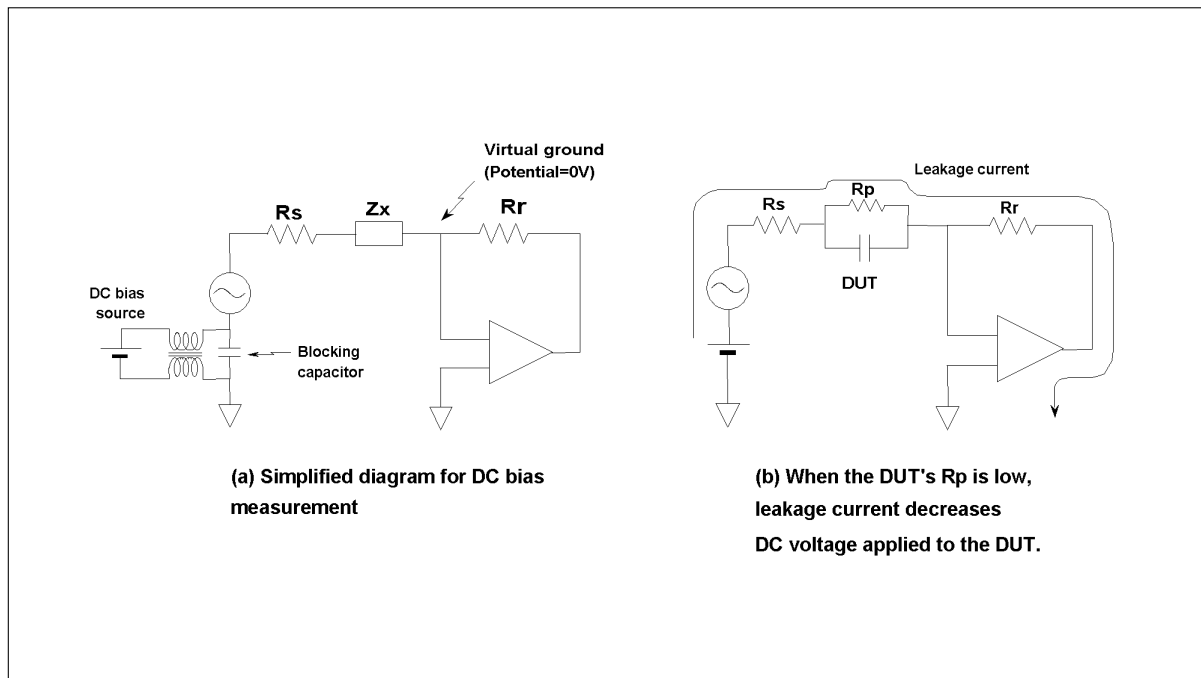


Figure 2-7. DC bias applied to DUT referenced to virtual ground

2-4-3. Ranging function

To measure impedance from low values to high values, impedance measurement instruments have several measurement ranges. Generally, 7 to 10 measurement ranges are available and the instrument can automatically select the appropriate measurement range according to the DUT's impedance. Range changes are generally accomplished by changing gain multiplier of the vector ratio detector, and by switching the range resistor (Figure 2-8 (a)). This insures that the maximum signal level is fed into the A to D converter to give the highest S/N ratio for maximum measurement accuracy.

The range boundary is generally specified at two points to give an overlap between adjacent ranges. Range changes occurs with hysteresis as shown in Figure 2-8 (b), to prevent frequent range changes due to noise.

On any measurement range, the maximum accuracy is obtained when the measured impedance is close to the full-scale value of the range being used. Conversely, if the measured impedance is much lower than the full-scale value of the range being used, the measurement accuracy will be degraded. This sometimes causes a discontinuity in the measurement values at the range boundary. When the range change occurs, the impedance curve will skip. To prevent this, the impedance range should be set manually to the range which measures higher impedance.

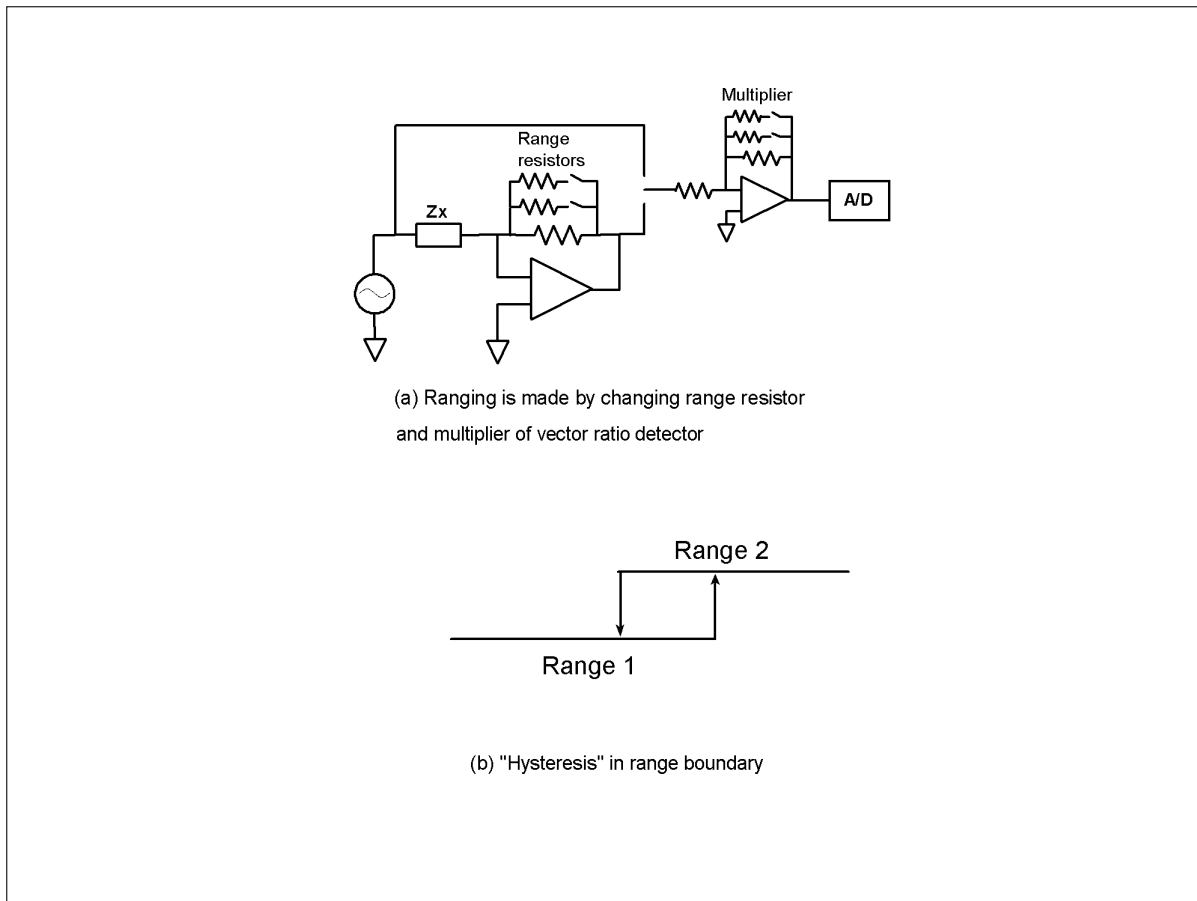


Figure 2-8. Ranging function

2-4-4. Level monitor function

Monitoring the test signal voltage or current applied to the DUT is important for maintaining accurate test conditions, especially when the DUT has a test signal level dependency. The level monitor function measures the actual signal level across the DUT. As shown in Figure 2-9, the test signal voltage is monitored at the High terminal and the test signal current is calculated using the value of range resistor R_r and the voltage across it.

Instruments equipped with Auto Level Control (ALC) function can automatically maintain a constant test signal level. By comparing the monitored signal level with the test signal level setting value, the ALC adjusts the oscillator output until the monitored level meets the setting value. There are two ALC methods: analog and digital. The analog type has an advantage in providing a fast ALC response, whereas the digital type has an advantage in performing a stable ALC response for a wide range of DUT impedance (capacitance and inductance.)

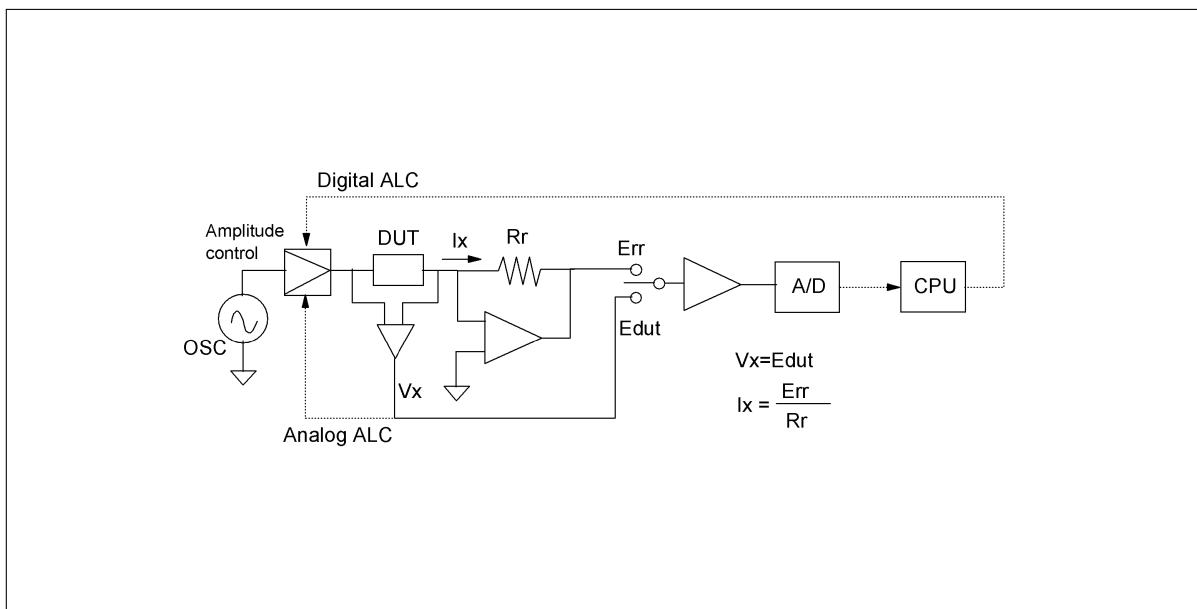


Figure 2-9. Test signal level monitor and ALC function

2-4-5. Measurement time and averaging

Achieving optimum measurement results depends upon measurement time, which may vary according to the control settings of the instrument (frequency, IF bandwidth, etc.). When selecting the measurement time modes, it is necessary to take some tradeoffs into consideration. Speeding up measurement normally conflicts with the accuracy, resolution, and stability of measurement results.

The measurement time is mainly determined by operating time (acquisition time) of the A-D converter in the vector ratio detector. To meet the desired measurement speed, modern impedance measurement instruments use a high speed sampling A-D converter, in place of the previous technique which used a phase detector and a dual-slope A-D converter. Measurement time is proportional to the number of sampling points taken to convert the analog signal (E_{dut} or Err) into digital data for each measurement cycle. Selecting a longer measurement time results in taking a greater number of sampling points for more digital data, thus improving measurement precision.

Theoretically, random noise (variance) in a measured value proportionately decreases inversely to the square root of the A-D converter operating time.

Averaging function calculates the mean value of measured parameters from the desired number of measurements. Averaging has the same effect on random noise reduction as that by using a long measurement time.

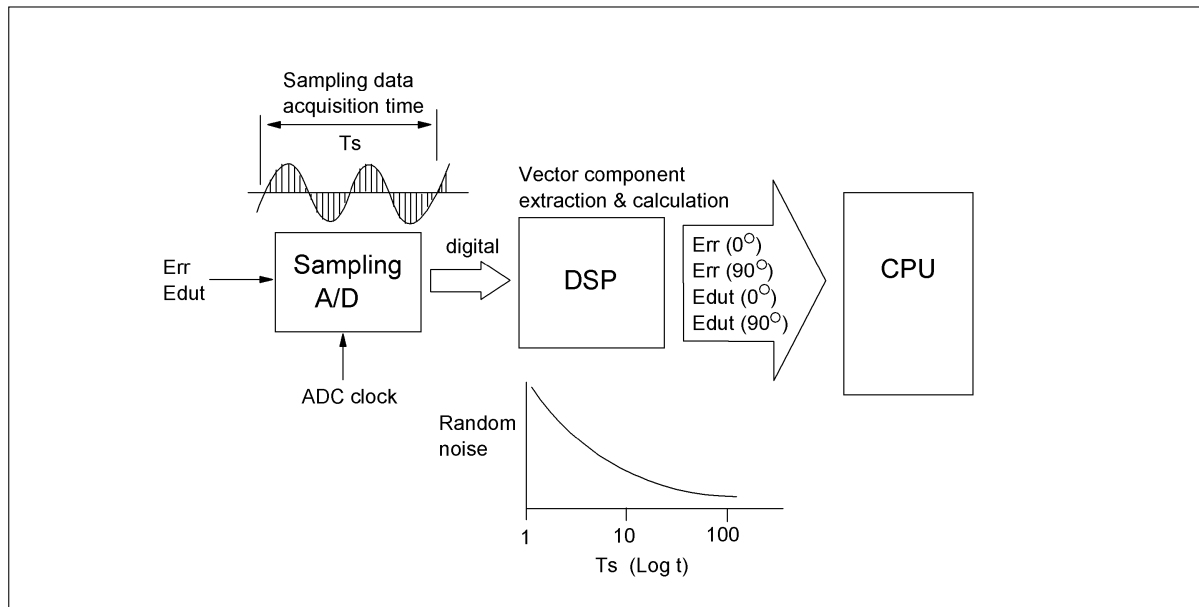


Figure 2-10. Relationship of measurement time and precision

2-4-6. Compensation function

Impedance measurement instruments are calibrated at UNKNOWN terminals and, measurement accuracy is specified at the calibrated reference plane. However, an actual measurement cannot be made directly at the calibration plane because the UNKNOWN terminals do not geometrically fit to the shapes of components that are to be tested. Various types of test fixtures and test leads are utilized to ease connection of the DUT to the measurement terminals. (The DUT is placed across the test fixture's terminals, not at the calibration plane.) As a result, a variety of error sources (such as residual impedance, admittance, electrical length, etc.) are involved in the circuit between the DUT and the UNKNOWN terminals. The instrument's compensation function eliminates measurement errors due to these error sources. Generally, the instruments have the following compensation functions:

- Open/short compensation or open/short/load compensation
- Cable length compensation

The open/short compensation function removes the effects of the test fixture's residuals. The open/short/load compensation allows complicated errors to be removed where the open/short compensation is not effective. The cable length compensation offsets the error due to the test lead's transmission characteristics.

The induced errors are dependent upon test frequency, test fixture, test leads, DUT connection configuration, and surrounding conditions of the DUT. Hence, the procedure to perform compensation with actual measurement setup is a key technique to obtain accurate measurement results. The compensation theory and practice are discussed comprehensively in Section 4.

2-4-7. Guarding

When in-circuit measurements are being performed or when one parameter of a three terminal device is to be measured, for the targeted component, as shown in Figure 2-11 (a), the effects of paralleled impedance can be reduced by using guarding techniques. The guarding techniques can also be utilized to reduce the outcome of stray capacitance when the measurements are affected by the strays present between the measurement terminals or between the DUT terminals and a closely located conductor. (Refer to paragraph 3-5 for the methods of eliminating the stray capacitance effects.)

The guard terminal is the circuit common of the auto balancing bridge and is connected to the shields of the 4-terminal pair connectors. The guard terminal is electrically different from the ground terminal which is connected directly to the chassis (Figure 2-11 (b)). When the guard is properly connected as shown in Figure 2-11 (c), it reduces the test signal current but does not affect the measurement of the DUT's impedance Z_x , because Z_x is calculated using current I_x .

The details of the guard effects are described as follows. The current I_1 , which flows through Z_1 , does not flow into the ammeter. As long as I_1 does not cause a significant voltage drop of the applied test signal, it scarcely influences on measurements. The current I_2 , which is supposed to flow through Z_2 , is small and negligible compared to I_x , because the internal resistance of the ammeter (equivalent input impedance of the auto balancing bridge circuit) is very low in comparison to Z_2 . In addition, the potential at the Low terminal of the bridge circuit, in the balanced condition, is zero (virtual ground). However, if Z_2 is too low, the measurement will become unstable because ammeter noise increases.

Note: In order to avoid possible bridge unbalance and not cause significant measurement errors, Z_2 should not be lower than certain impedance. Minimum allowable value of Z_2 depends on Z_x , test cable length, test frequency and other measurement conditions.

The actual guard connection is shown in Figure 2-11 (d). The guard lead impedance Z_g should be as small as possible. If Z_g is not low enough, an error current will flow through the series circuit of Z_1 and Z_2 and, it is parallel with I_x .

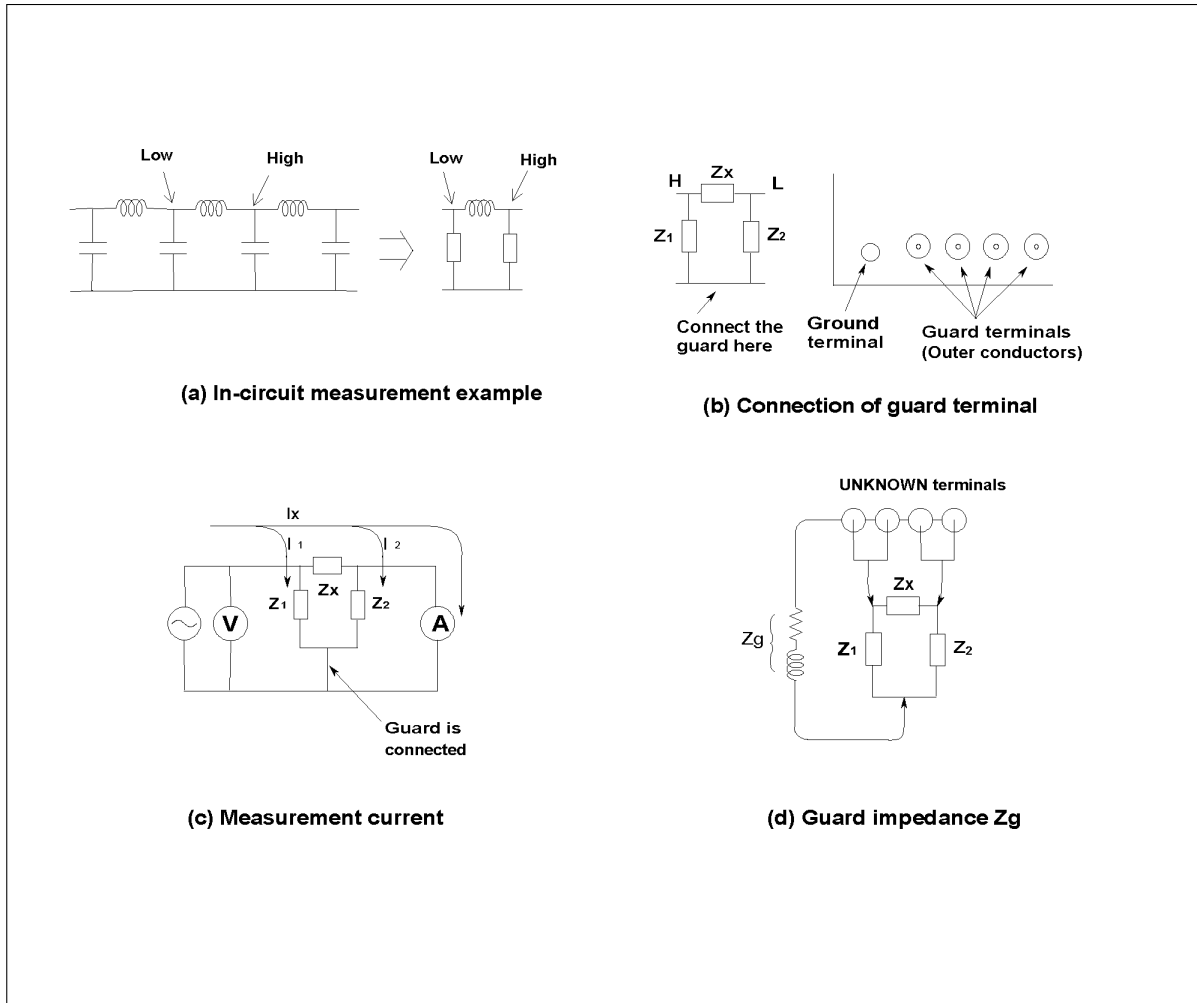


Figure 2-11. Guarding techniques

2-4-8. Grounded device measurement capability

Grounded devices such as the input/output of an amplifier can be measured directly using the I-V measurement method or the reflection coefficient measurement method (Figure 2-12 (a)). However, it is difficult for an auto balancing bridge to measure low-grounded devices because the measurement signal current bypasses the ammeter (Figure 2-12 (b)). Measurement is possible only when the chassis ground is isolated from the DUT's ground. (Note: The 4294A used with the 42941A or the 42942A will result in grounded measurements.)

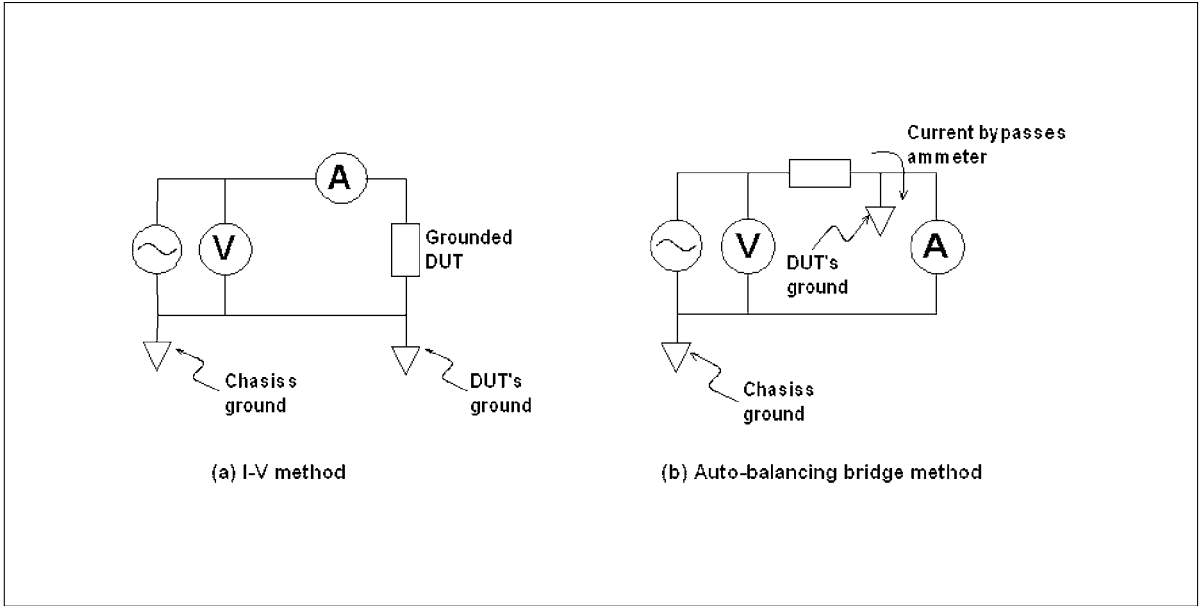


Figure 2-12. Low-grounded device measurement

2-5. Theory of RF I-V measurement method

The RF I-V method featuring Agilent's RF impedance analyzers and RF LCR meters is an advanced technique to measure impedance parameters in the high frequency range, beyond the frequency coverage of the auto balancing bridge method. It provides better accuracy and wider impedance range than the network analysis (reflection coefficient measurement) instruments can offer. This paragraph discusses the brief operating theory of the RF I-V method using a simplified block diagram as shown in Figure 2-13.

The **signal source section** generates an RF test signal applied to the unknown device and has a variable frequency range from 1 MHz to 3 GHz (typical). Generally, a frequency synthesizer is used to meet frequency accuracy, resolution and sweep function needs. The amplitude of signal source output is adjusted for the desired test level by the output attenuator.

The **test head section** is configured with a current detection transformer, V/I multiplexer, and test port. The measurement circuit is matched to the characteristic impedance of $50\ \Omega$ to ensure optimum accuracy at high frequencies. The test port also employs a precision coaxial connector of $50\ \Omega$ characteristic impedance. Since the test current flows through the transformer, in series with the DUT connected to the test port, it can be measured from the voltage across the transformer's winding. The V channel signal, E_{dut} , represents the voltage across the DUT and the I channel signal, E_{tr} , represents the current flowing through the DUT. Because the measurement circuit impedance is fixed at $50\ \Omega$, all measurements are made in reference to $50\ \Omega$ without ranging operation.

The **vector ratio detector section** has similar circuit configurations as the auto balancing bridge instruments. The V/I input multiplexer alternately selects the E_{dut} and E_{tr} signals so that the two vector voltages are measured with identical vector ratio detector to avoid tracking errors. The measuring ratio of the two voltages derives the impedance of the unknown device as $Z_x = 50 \times (E_{dut}/E_{tr})$. To make the vector measurement easier, the mixer circuit down-converts frequency of the E_{dut} and E_{tr} signals to an IF frequency suitable for the A-D converter's operating speed. In practice, double or triple IF conversion is used to obtain spurious-free IF signals. Each vector voltage is converted into digital data by the A-D converter and is digitally separated into 0° and 90° vector components.

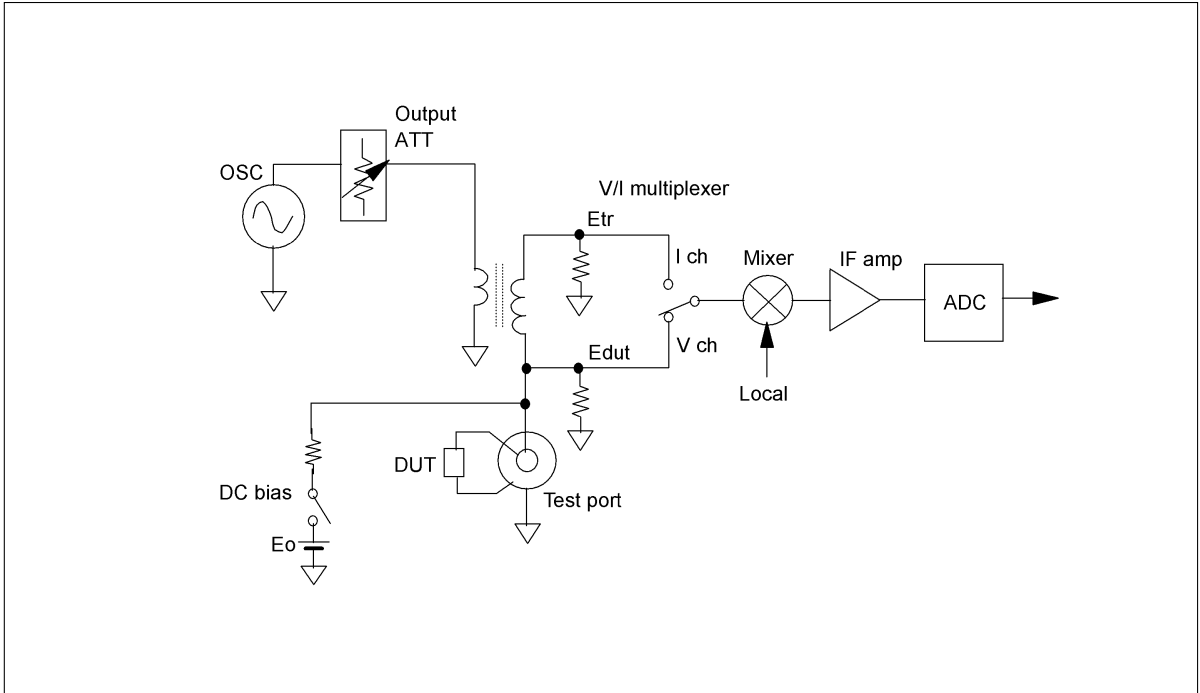


Figure 2-13. Simplified block diagram for RF I-V method

2-6. Difference between RF I-V and network analysis measurement methods

When testing components in the RF region, the RF I-V measurement method is often compared with network analysis. The difference in principle is highlighted as the clarifying reason why the RF I-V method has advantages over the reflection coefficient measurement method, commonly used with network analysis.

The network analysis method measures the reflection coefficient value, Γ_x , of the unknown device. Γ_x is correlated with impedance, by the following equation:

$$\Gamma_x = (Z_x - Z_0) / (Z_x + Z_0)$$

Where, Z_0 is the characteristic impedance of the measurement circuit (50 Ω) and Z_x is DUT impedance. In accordance with this equation, measured reflection coefficient varies from -1 to 1 depending on the impedance, Z_x . The relationship of reflection coefficient to impedance is graphically shown in Figure 2-14. The reflection coefficient curve in the graph affirms that the DUT is resistive. As the graph indicates, the reflection coefficient sharply varies, with difference in impedance (ratio), when Z_x is near Z_0 (that is, when Γ_x is near zero). The highest accuracy is obtained at Z_x equal to Z_0 because the directional bridge for measuring reflection detects the “null” balance point. The gradient of reflection coefficient curve becomes slower for both the lower and higher impedance, causing deterioration of impedance measurement accuracy. In contrast, the principle of the RF I-V method is based on the linear relationship of voltage-current ratio to impedance, as given by ohm’s law. Thus, the theoretical impedance measurement sensitivity is constant, regardless of measured impedance (Figure 2-15 (a)). The RF I-V method has measurement sensitivity which is superior to the reflection coefficient measurement except for a very narrow impedance range around the null balance point ($\Gamma=0$ or $Z_x=Z_0$) of the directional bridge.

Note: Measurement sensitivity is a change in measured signal levels ($\Delta V/I$ or $\Delta V/V$) relative to a change in DUT impedance ($\Delta Z/Z$). The measurement error approximates to the inverse of the sensitivity.

The reflection coefficient measurement never exhibits such high peak sensitivity for capacitive and inductive DUTs, because the directional bridge does not have the null balance point for reactive impedance. The measurement sensitivity of the RF I-V method also varies, depending on the DUT’s impedance, because the measurement circuit involves residuals and the voltmeter and current meter are not ideal (Figure 2-15 (b)). (Voltmeter and current meter arrangement influences the measurement sensitivity.) Though the measurable impedance range of the RF I-V method is limited by those error sources, it can cover a wider range than in the network analysis method. The RF I-V measurement instrument provides a typical impedance range from 0.2 Ω to 20 k Ω at the calibrated test port, while the network analysis is typically from 2 Ω to 1.5 k Ω (depending upon the required accuracy and measurement frequency).

Note: Typical impedance range implies measurable range within 10% accuracy.

Moreover, because the vector ratio measurement is multiplexed to avoid phase tracking error and, because calibration referenced to a low loss capacitor can be used, accurate and stable measurement of low dissipation factor (high Q factor) is enabled. The Q factor accuracy of the network analysis and the RF I-V methods are compared in Figure 2-16.

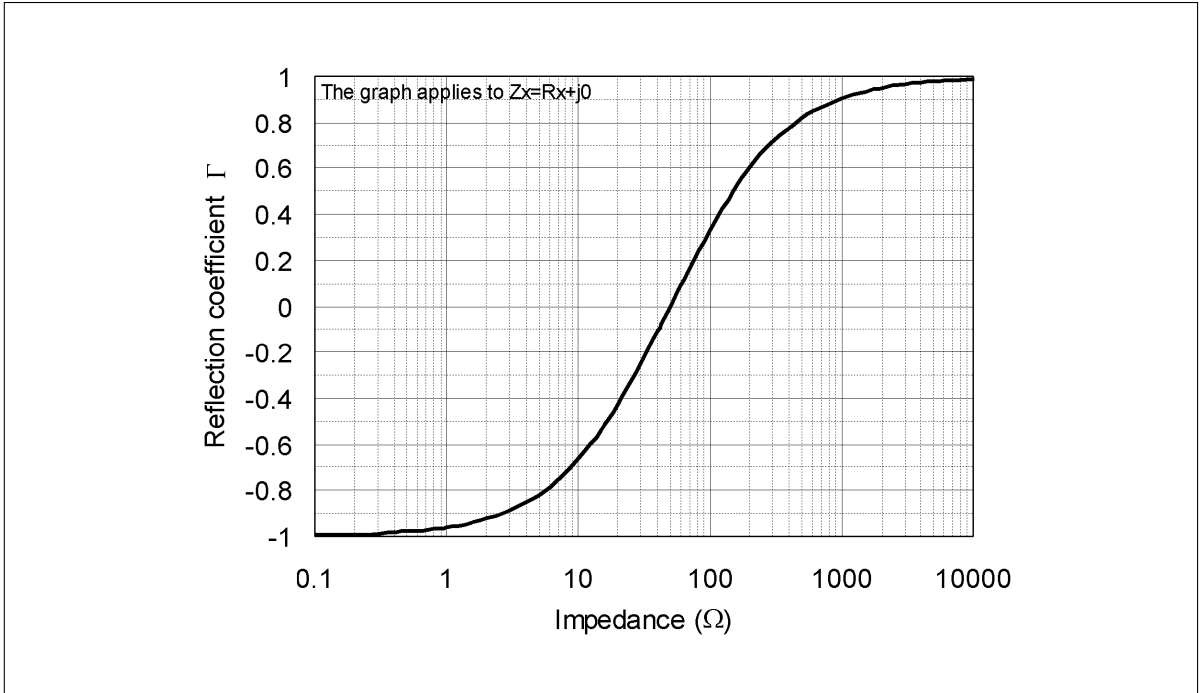


Figure 2-14. Relationship of reflection coefficient to impedance

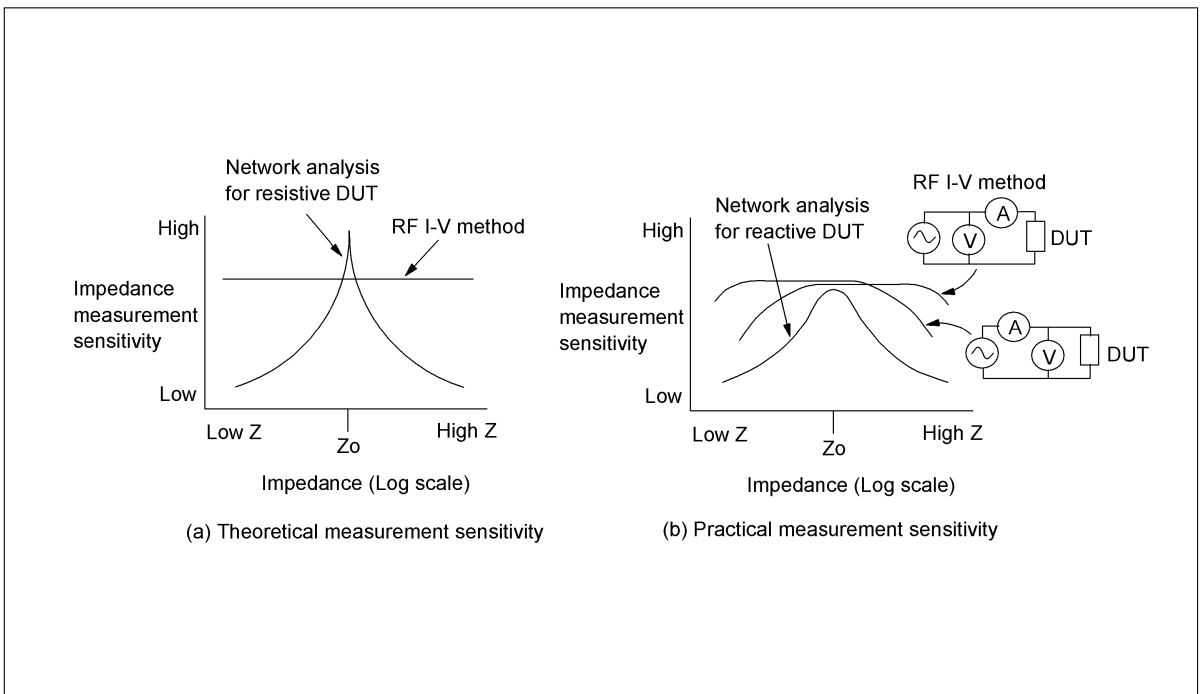


Figure 2-15. Measurement sensitivity of network analysis and RF I-V methods

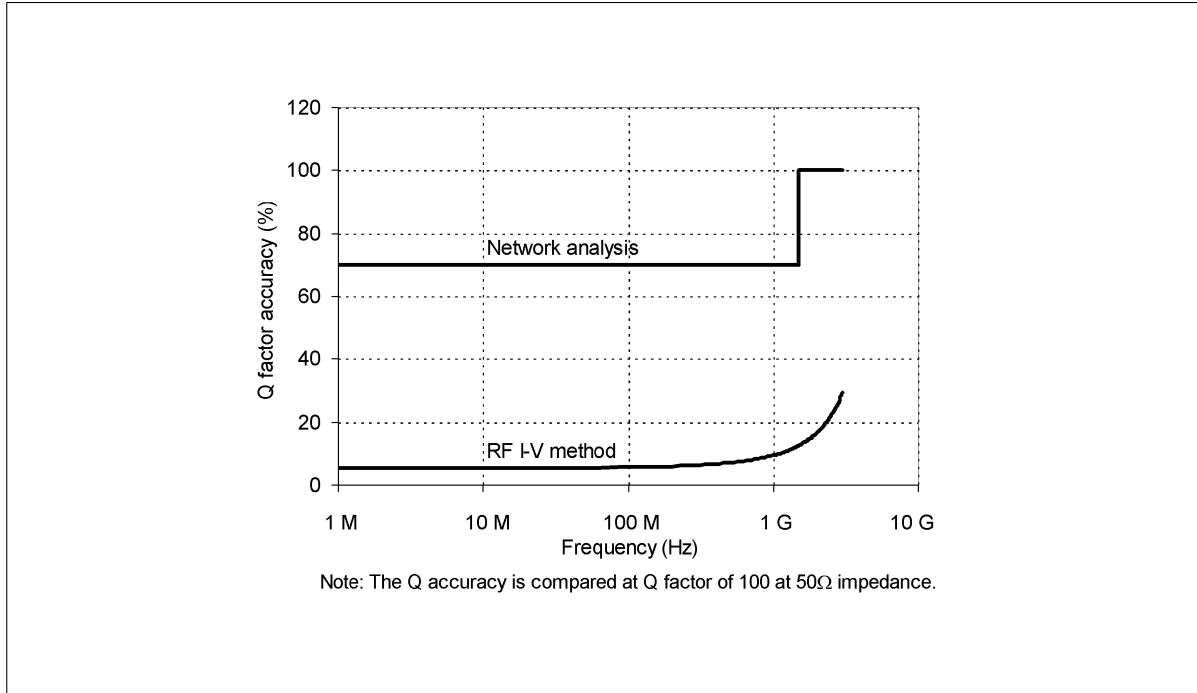


Figure 2-16. Comparison of typical Q accuracy

2-7. Key measurement functions

2-7-1. OSC level

The oscillator output signal is output through the coaxial test port (coaxial connector) with source impedance of 50 Ω . The oscillator output level can be controlled to change the test signal level applied to the DUT. Specified test signal level is obtained when the connector is terminated with a 50 Ω load (The signal level for open or short condition is calculated from that for 50 Ω). When a DUT is connected to the measurement terminals, the current that flows through the DUT will cause a voltage drop at the 50 Ω source impedance (resistive). Actual test signal level applied to the device can be calculated from the source impedance and the DUT's impedance as shown in Figure 2-6. Those instruments equipped with level monitor function can display the calculated test signal level and measurement results.

2-7-2. Test port

The test port of the RF I-V instrument usually employs a precision coaxial connector to ensure optimum accuracy throughout high frequency range. The coaxial test port allows RF test fixtures to be attached and the instrument to be calibrated using traceable coaxial standard terminations. The test port is a two-terminal configuration and does not have a guard terminal separate from a ground terminal. Therefore, the guarding technique does not apply as well to the RF I-V measurements as compared to network analysis.

2-7-3. Calibration

Most of the RF vector measurement instruments such as network analyzers need to be calibrated each time a measurement is initiated or a frequency setting is changed. The RF I-V measurement instrument requires calibration as well. At higher frequencies, a change in the instrument's operating conditions, such as, environmental temperature, humidity, frequency setting, etc., have a greater effect on measurement accuracy. This nature of RF vector measurement makes it difficult to sufficiently maintain the calibrated measurement performance over a long period of time. Thus, users have to periodically perform requisite calibration.

Note: Calibration is necessary each time a measurement setup is changed.

Calibration is executed in reference to three standard terminations, open, short and load, and all three must be performed. To improve the accuracy of low dissipation factor measurements (high Q factor), calibration with a low loss capacitor can be performed. The theory of calibration and appropriate calibration methods are discussed in Section 4.

2-7-4. Compensation

Two kinds of compensation functions are provided: open/short compensation for eliminating the errors due to test fixture residuals and electrical length compensation for minimizing the test port extension induced error. Practical compensation methods are discussed in Section 4.

2-7-5. Measurement range

RF I-V measurement method as well as network analysis covers the full measurement range from low impedance to high impedance without ranging operation. All measurements are made at single broad range.

2-7-6. DC bias

The internal DC bias source is connected to the center conductor of the coaxial test port and applies a bias voltage to the DUT. The internal bias function can be set to either the voltage source mode or the current source mode. The voltage source mode is adequate to the voltage-biased measurement of capacitive DUT. The current source mode is to the current-biased measurement of inductive DUT. Actual bias voltage and current across the DUT are monitored and, within specified voltage/current output compliance ranges, automatically regulated at the same level as the bias setting value regardless of the DUT's DC resistance, thus allowing accurate DC bias to be applied across the DUT. Since the internal bias source cannot output bias current large enough for inductor measurements, generally, current-biased measurement (in excess of maximum output current) requires an external bias method to be used. For biasing up to 5 A and 40 V in frequency range below 1 GHz, the 16200B bias adapter compatible with RF I-V instruments is available.

This page intentionally left blank.

SECTION 3

Fixturing and cabling

When interconnecting a device under test (DUT) to the measurement terminals of the auto balancing bridge instrument, there are several connection configurations to choose from. This section will introduce the basic theory and use of each connection configuration focussing on the auto balancing bridge instrument. In RF impedance measurements, the usable connection configuration is the two terminal method only. Since the measurement technique for RF impedance is different from that for LF, it is described separately after the discussion of the auto balancing bridge instrument.

3-1. Terminal configuration

An auto balancing bridge instrument is generally equipped with four BNC UNKNOWN terminals (Hc, Hp, Lp and Lc) on its front panel. There are several connection configurations used to interconnect a DUT to the UNKNOWN terminals. Because each method has advantages and disadvantages, the most suitable method must be selected based on the DUT's impedance and required measurement accuracy.

The **two-terminal (2T) configuration** is the simplest way but contains many error sources. Lead inductance, lead resistance, and stray capacitance between two leads have been added to the measurement result (Figure 3-1). Because of the existence of these error sources, the typical impedance measurement range (without doing compensation) is limited to 100 Ω to 10 k Ω .

The **three-terminal (3T) configuration** employs coaxial cables to reduce the effects of stray capacitance. The outer conductors (shield) of the coaxial cables are connected to the guard terminal. Measurement accuracy is improved on the higher impedance measurement range but not on lower impedance measurement range because lead inductance and resistance still remain. (See Figure 3-2.) The typical impedance range will be extended above 10 k Ω . If the outer conductor is connected as shown in Figure 3-2 (d), lower impedance measurement accuracy is a little improved. (Shielded 2T configuration.)

The **four-terminal (4T) configuration** can reduce the effects of lead impedances because the signal current path and the voltage sensing cables are independent (Figure 3-3). Accuracy for the lower impedance measurement range is improved typically down to 1 Ω . When the DUT's impedance is lower than 1 Ω , a large signal current flows through the current path and mutual (M) coupling to the voltage sensing cable will cause an error.

The **five-terminal (5T) configuration** is a combination of the 3T and 4T configurations. It is equipped with four coaxial cables and all of the outer conductors of the four cables are connected to the guard terminal (Figure 3-4). This configuration has a wide measurement range from 1 Ω to 10 M Ω , but the mutual coupling problem still remains. If the outer conductor is connected as shown in Figure 3-4 (d), lower impedance measurement accuracy is a little improved. (Shielded 4T configuration.)

The **four-terminal pair (4TP) configuration** solves the mutual coupling problem because it uses coaxial cable to isolate the voltage sensing cables from the signal current path (Figure 3-5). Since the return current flows through the outer conductor of the coaxial cable, the magnetic flux generated by the inner conductor is canceled by that of the outer conductor (shield). The measurement range for this configuration can be improved to below $1\ \Omega$. The impedance measurement range realizable for this configuration depends on the measurement instrument and on how well the 4TP configuration is strictly adhered to up to the connection point of the DUT. If the cables are not connected properly, measurement range will be limited, or in some cases, measurement cannot be made. Figure 3-5 (d) shows an example of incorrect configuration.

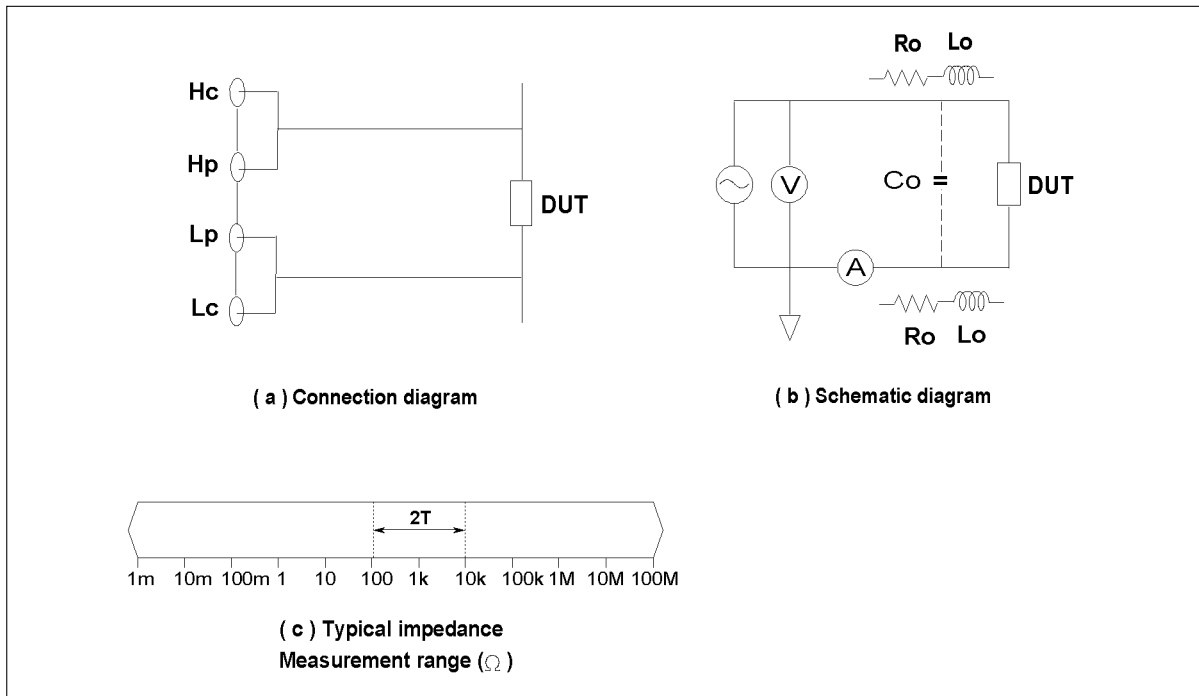


Figure 3-1. Two-terminal (2T) configuration

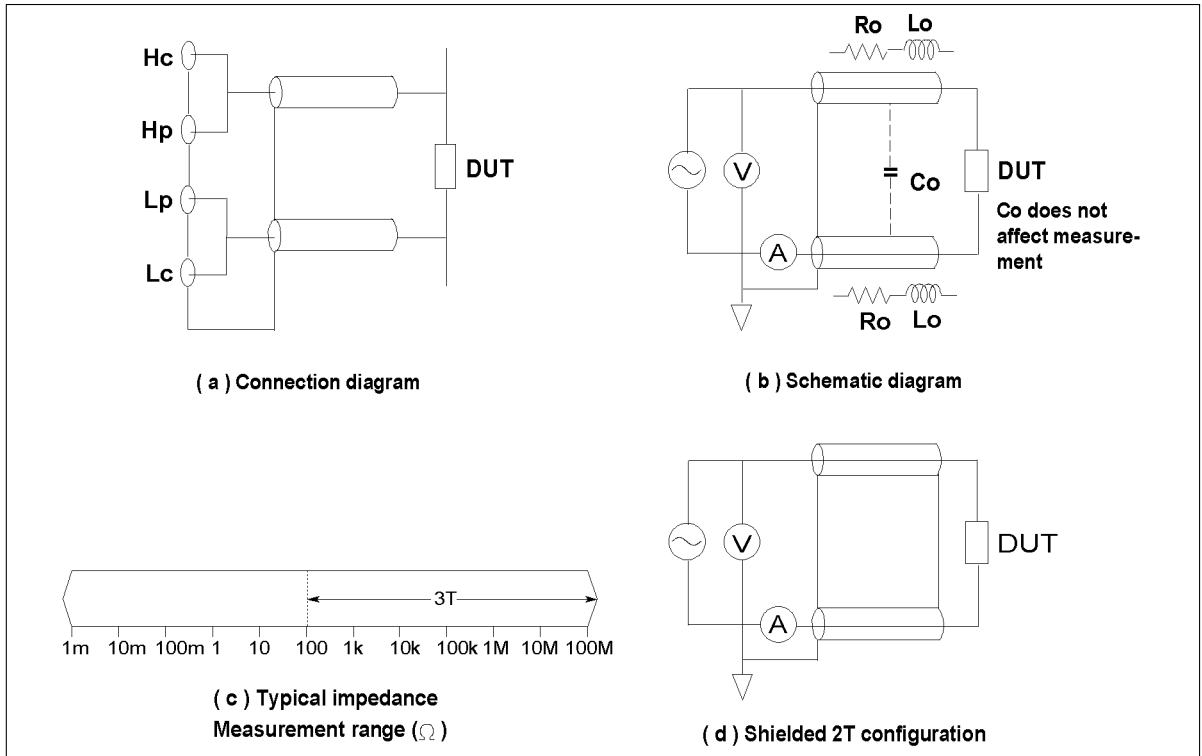


Figure 3-2. Three-terminal (3T) configuration

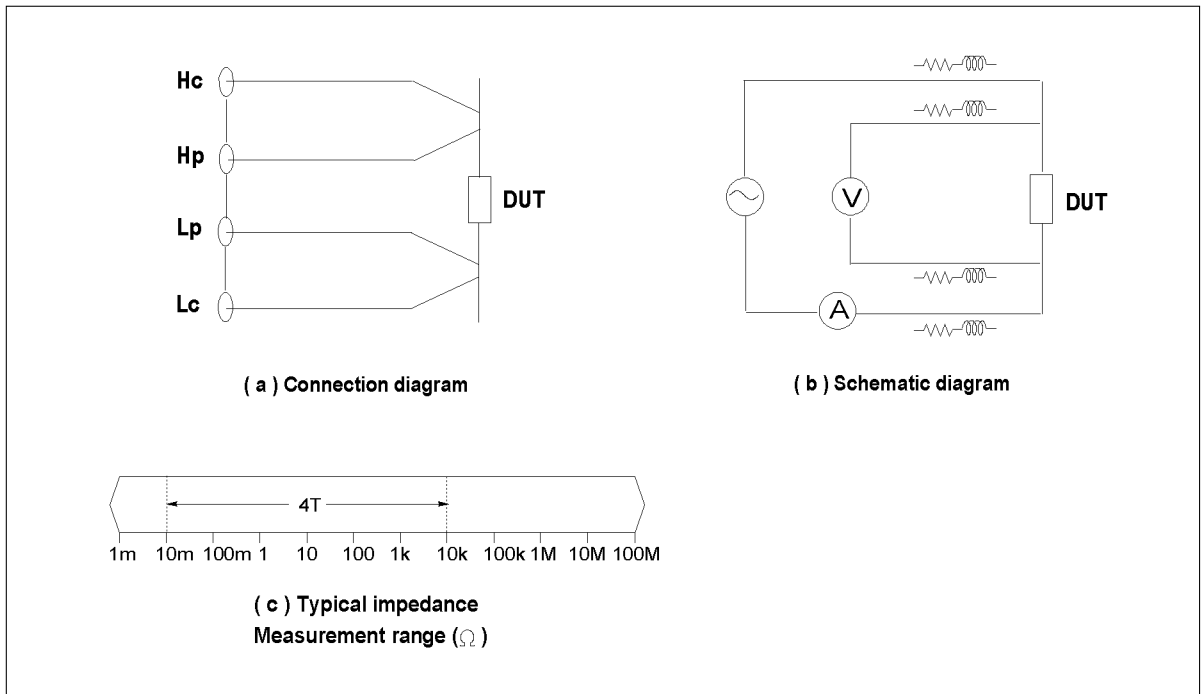


Figure 3-3. Four-terminal (4T) configuration

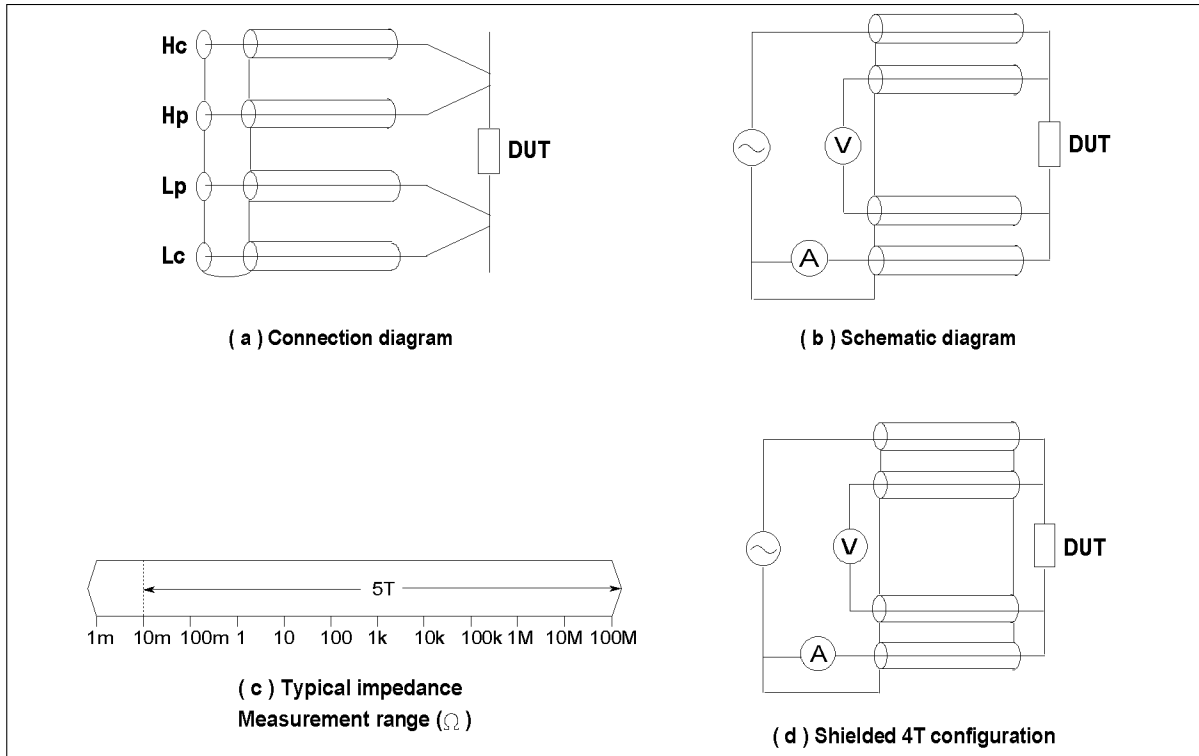


Figure 3-4. Five-terminal (5T) configuration

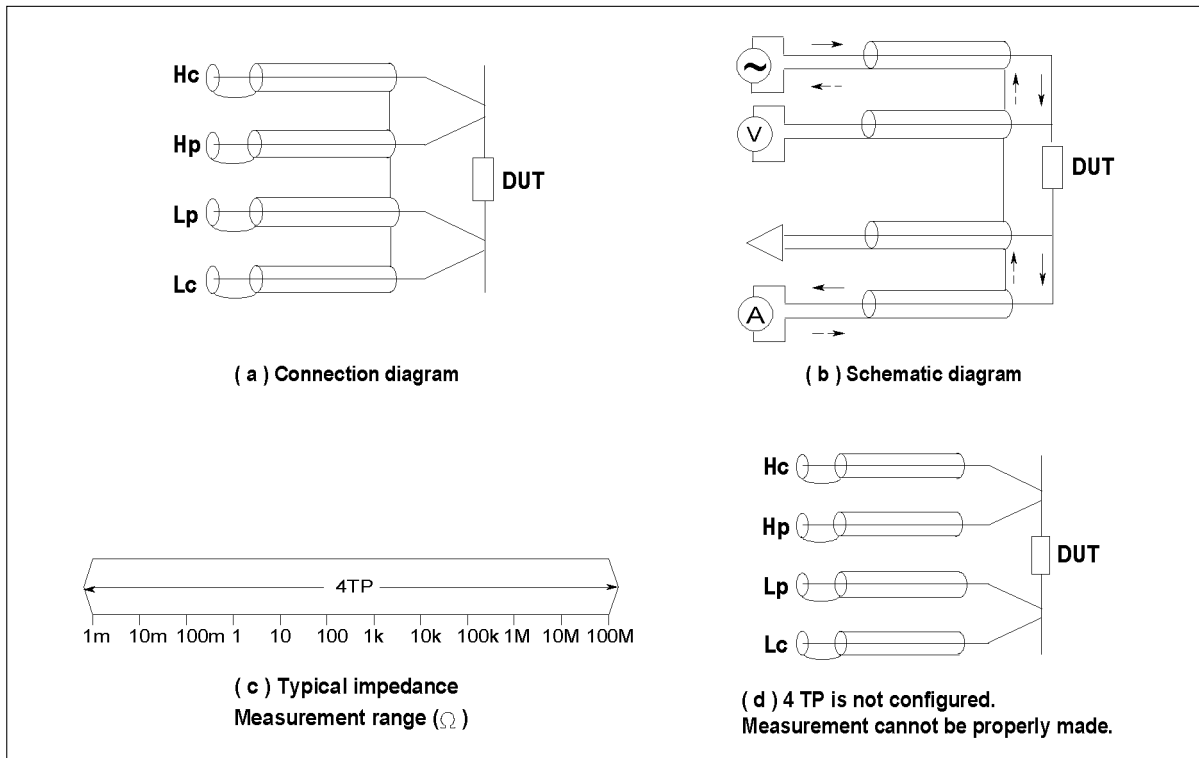


Figure 3-5. Four-terminal pair (4TP) configuration

3-2. Using test cables at high frequencies

The 4TP configuration is the best solution for wide-range impedance measurement. However, in basic 4TP measurement, its cable length is limited by the measurement frequency because the length of the cable must be much shorter than the wavelength. The following equation gives a typical guideline for determining the limitation:

$$F \times L \leq 15$$

Where: F is the measurement frequency (MHz)

L is the cable length (m)

When the cable length is 1 m, the maximum frequency limit will be approximately 15 MHz. If the cable length or frequency exceeds this limit, the auto balancing bridge may not balance. Generally, 4TP measurement instruments have this cable length limitation, but there are some exceptional instruments, such as 4294A, which permit using test cables at frequencies over the limits. These instruments obviate the limitation by having measurement circuit impedance matched to the characteristic impedance of specified test cables at high frequencies. (Note that practical cable length limit due to increase in measurement error still exists.)

Cable length compensation is also necessary for higher frequency impedance measurement (typically above 100 kHz). In the higher frequency region, transmission characteristics of the cable will cause an error and it depends on the type of cable used. As a recommendation, use the standard Agilent test cables. Agilent's impedance measurement instruments can compensate for known transmission characteristics of the cables. A detailed discussion on the error and how to compensate for it is provided in Section 4.

3-3. Test fixtures

The test fixture plays an important role in impedance measurement in both mechanically and electrically. The quality of the fixture determines the limit of the total measurement quality. Discussion on how to choose or fabricate a fixture follows.

3-3-1. Agilent supplied test fixtures

Agilent Technologies supplies various types of test fixtures depending on the type of device being tested. To choose the most suitable test fixture for the DUT, consider not only the physical layout of the contacts but also the usable frequency range, residual parameters (usable impedance range), and the allowable DC voltage that can be applied.

The contact terminals of the test fixtures (DUT connection) can be either 2-terminal or 4-terminal that are suited to different applications. The DUT connection configuration and suitable application of Agilent's test fixtures are summarized in Table 3-1.

Note: The terminal configuration in this case is described for the contact terminals only, not the whole circuit in the test fixture.

Table 3-1. Test fixture's DUT connection configuration and applications

DUT connection configuration	Applicable device type	Agilent test fixture	Basic characteristics	Suitable application
2-terminal	Leaded device	16047D 16047E 16065A 42842A/B/C	<ul style="list-style-type: none"> • Measurement is susceptible to the effect of residual impedance and contact resistance • Usable frequency limit is high • Additional error at high frequencies is smaller than in 4-terminal connection 	Middle and high impedance DUTs and high frequency measurements.
	Surface mounted device	16034E 16034G 16034H 16334A		
	Material	16451B 16452A		
	In-circuit device	16095A 42941A		
4-terminal	Leaded device	16047A 16089A/B/C/D/E	<ul style="list-style-type: none"> • Measurement is less affected by residual impedance and contact resistance (at relatively low frequencies) • Usable frequency limit is low • Additional error at high frequencies is greater than in 2-terminal connection 	Low and middle impedance DUTs and low frequency measurements.
	Surface mounted device	16044A		

3-3-2. User fabricated test fixtures

If the DUT is not applicable to Agilent supplied test fixtures, create an application specific test fixture. Key points to consider when fabricating a test fixture are:

- (1) **Residuals must be minimized.** To minimize the residuals, the 4TP configuration should be maintained as close as possible to the DUT. Also, proper guarding techniques will eliminate the effects of stray capacitance. See “Eliminating the stray capacitance effect” given in this section for practical use of guarding.
- (2) **Contact resistance must be minimized.** Contact resistance will cause additional error. In the case of the 2T configuration, it directly affects the measurement result. The contact electrodes should hold the DUT firmly and should always be clean. Use a corrosion-free material for the electrodes.
- (3) **Contacts must be able to be opened and shorted.** Open/short compensation can easily reduce the effects of the test fixture residuals. To perform an open/short measurement, you must open and short the contact electrodes. For an open measurement, the contact electrodes should be located the same distance apart as when the DUT is connected. For the short measurement, a lossless (low impedance) conductor should be connected between the electrodes, or contact electrodes should be connected directly. If the four-terminal configuration is kept to the electrodes, make the connections of current and potential terminals and then make an open or short as shown in Figure 3-6.

3-3-3. User test fixture example

Figure 3-7 shows an example of a user fabricated test fixture. It is equipped with alligator clips as the contact electrodes for flexibility in making a connection to DUTs. Also, this test fixture can be connected directly to 4TP instruments. The assembly procedure for this test fixture is shown in Figure 3-7.

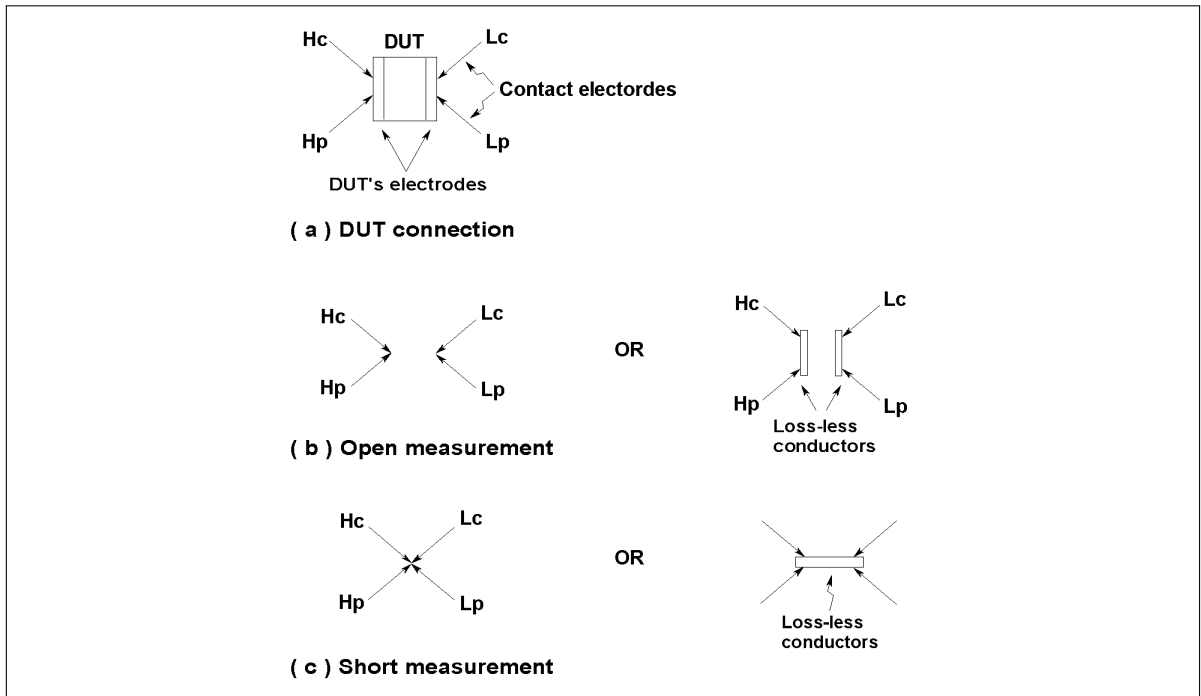


Figure 3-6. User fabricated test fixture open/short methods

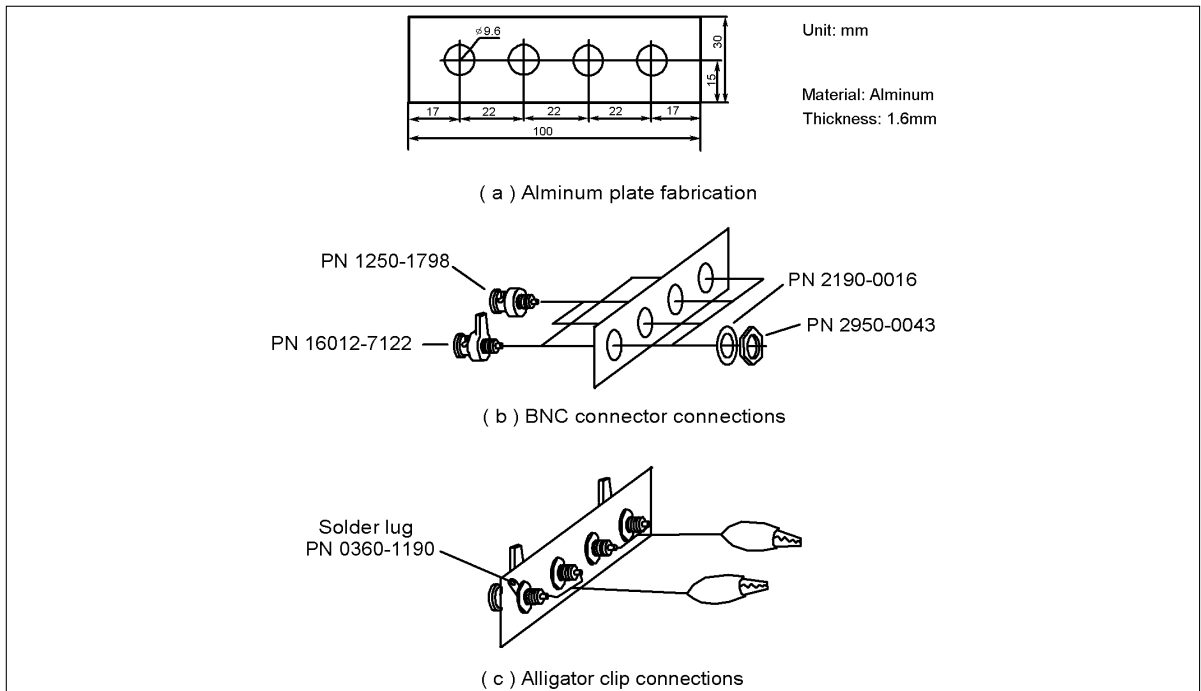


Figure 3-7. Example of fixture fabrication

3-4. Test cables

When the DUT is tested apart from the instrument, it is necessary to extend the test ports (UNKNOWN terminals) using cables. If the cables are extended without regard to their length, it will cause not only an error, but will also result in bridge unbalance making measurement impossible.

3-4-1. Agilent supplied test cables

Agilent Technologies supplies 1 m, 2 m and 4 m cables as listed in Table 3-2. The test cables from 16048A to 16048E are constructed using the same cable material. The 16048G and 16048H employ a high quality cable to insure low-loss transmission characteristics that specifically match to the 4294A. The cable length and the usable frequency range must be considered when selecting a test cable. Agilent's instruments can minimize the effects of test cables because the error of the cable is known. The measurement error will increase according to the cable length and the measurement frequency.

Table 3-2. Agilent supplied test cables

Test cable	Cable length	Maximum frequency	Connector type	Applicable instruments
16048A	1 m	30 MHz	BNC	4263B, 4268A, 4279A,
16048B			SMC	4284A, 4285A, 4288A
16048D	2 m	30 MHz	BNC	4263B, 4268A, 4279A, 4284A, 4285A, 4288A
16048E	4 m	1 MHz		4263B, 4284A
16048G	1 m	110 MHz		4294A
16048H	2 m	110 MHz		4294A

3-4-2. User fabricated test cable

Using cables other than those supplied by Agilent is not recommended. The cable compensation function of the instrument may not work properly in non-Agilent cables. If there is an unavoidable need to use non-Agilent cables, then use the same or equivalent cable that is used to make the Agilent test cables. The Agilent part number of the cable used for frequency below 30 MHz is 8120-0367 (not applicable to the 4294A.) Electrical specifications for these cables are provided in Figure 3-8. Do not use test cables other than Agilent supplied cables for higher frequencies. To extend the cables using the 4TP configuration, the cable length should be 1 m or 2 m so that the measurement instrument can compensate for it (depending on the instrument's cable length compensation function). If there is an error in the cable length, it will cause additional error. A detailed discussion is provided in Section 4.

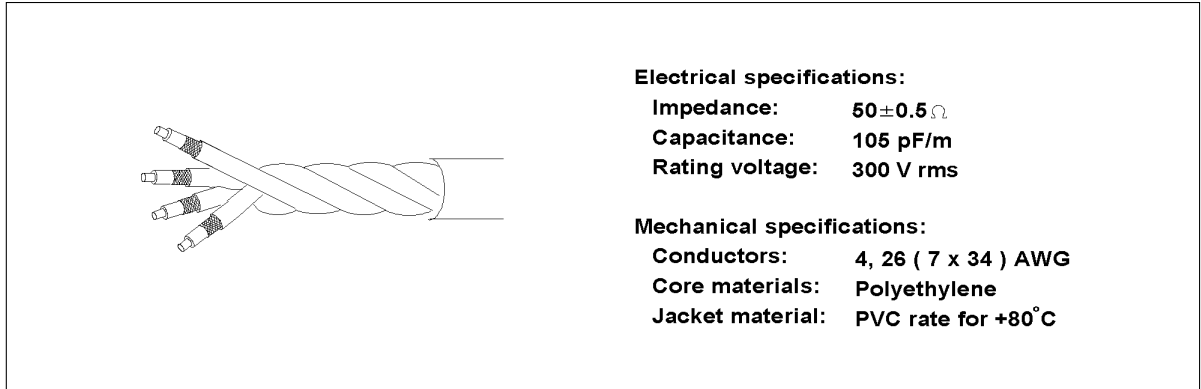


Figure 3-8. Specifications of recommended cable (Agilent PN 8120-0367)

3-4-3. Test cable extension

If the required test cable is longer than 1 m, 2 m, or 4 m, it is possible to extend the Agilent supplied test cable by using the following techniques.

4TP-4TP extension: As shown in Figure 3-9 (a), extension of the four coaxial cables should be connected together at the end of the extension. The actual connection is as shown in Figure 3-9 (b). An insulated connection plate must be used in order not to break the 4TP configuration. Four BNC(f) to BNC(f) adapters (Agilent PN 1250-0080 × 4) are used in this example. This technique can provide the best accuracy, especially for low impedance measurement. However, in basic 4TP measurement, its extension length is limited by the measurement frequency. $F(\text{MHz}) \times L(\text{m}) \leq 15$ is a typical estimation for extension limitation. For higher frequency measurements and longer extension, the shielded 2T extension technique, which is described next, should be utilized.

Shielded 2T extension: As shown in Figure 3-10 (a), the 4TP configuration is terminated and the extension cable configures a modified 3T (shielded 2T). The two outer conductors are connected together at each end of the cable. This will cancel the magnetic field induced by the inner conductors. This technique is used in the higher frequency region, up to 15 MHz. The residual impedance of the cable will be directly added to the measurement result but can be insignificant error source if the DUT's impedance is greater than the impedance due to the residuals. For the actual connection, a connector plate (Agilent PN 16032-60001) supplied with Agilent test cable can be used as shown in Figure 3-10 (b).

Shielded 4T extension: Lower impedance can be measured accurately when the shielded 4T configuration is connected as shown in Figure 3-11 (a). The actual connection is shown in Figure 3-11 (b).

Table 3-2 summarizes the extension techniques and their applicable impedance/frequency range.

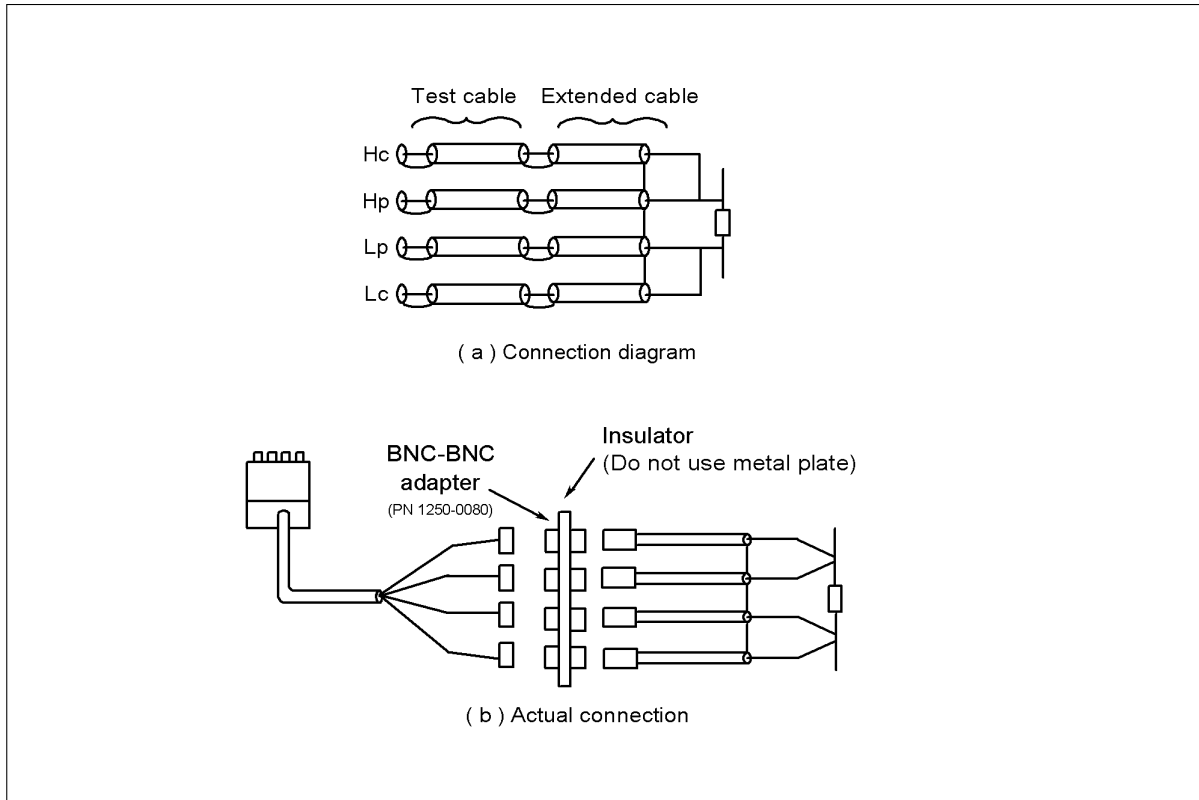


Figure 3-9. 4TP-4TP extension

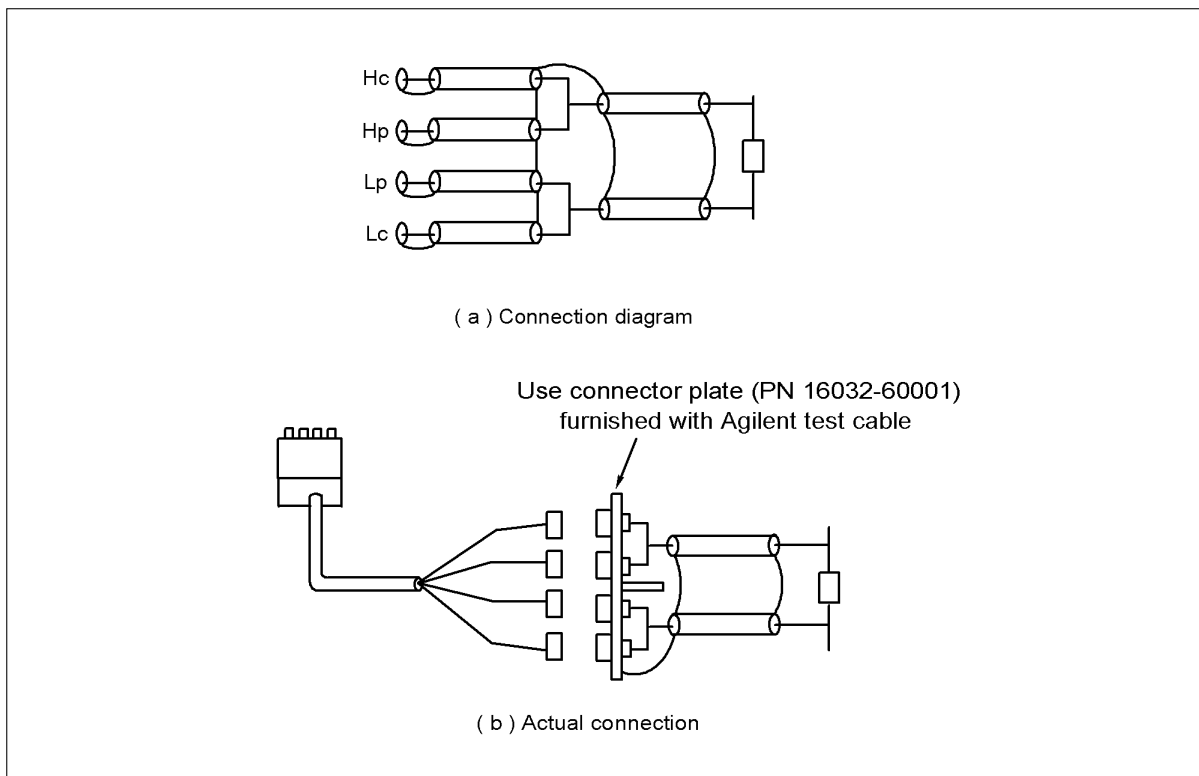


Figure 3-10. Shielded 2T extension

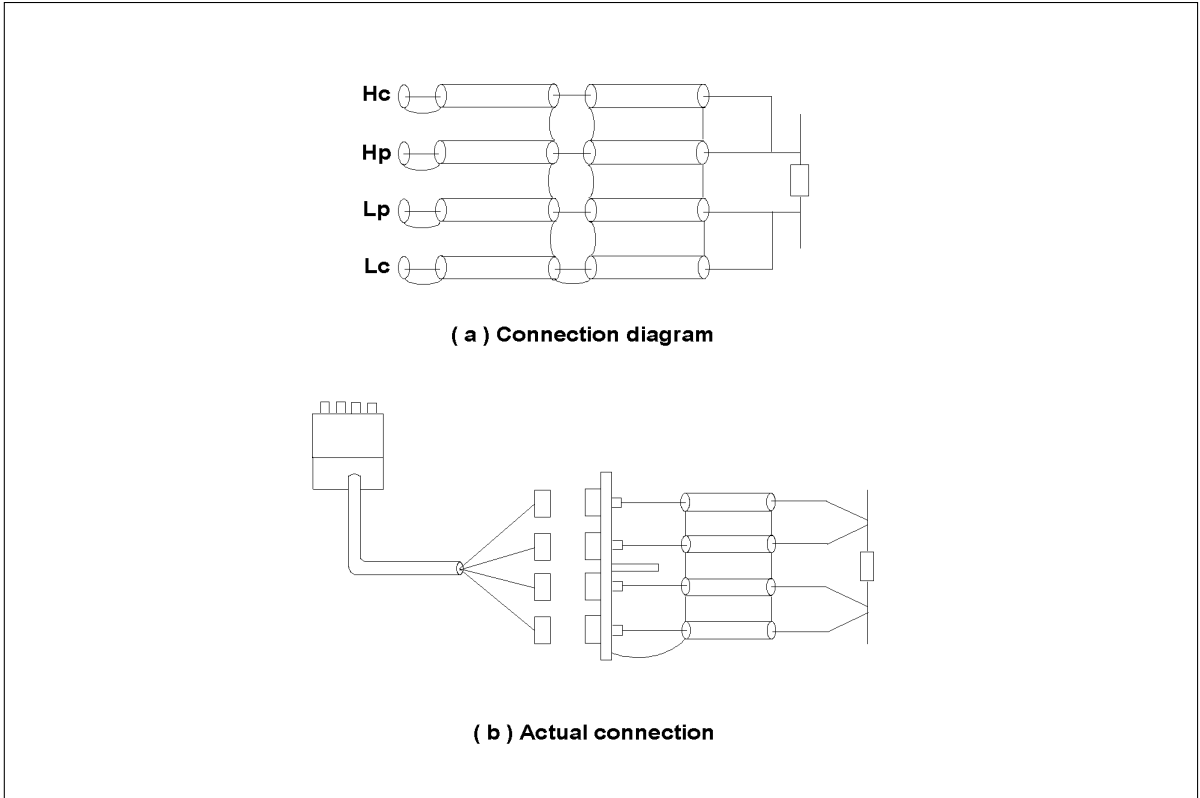


Figure 3-11. Shielded 4T extension

Table 3-2. Summary of cable extension

		Measurement frequency	
		100 kHz and below	100 kHz and above
Measured impedance	Low (Typically 100 Ω and below)	4TP-4TP	4TP-4TP
	Medium (Typically 100 Ω to 100 k Ω)		Shielded 4T
	High (Typically 100 k Ω and above)		Shielded 2T

3-5. Eliminating the stray capacitance effects

When the DUT has high impedance (e.g. Low Capacitance), the effects of stray capacitance are not negligible. Figure 3-12(a) shows an example of measuring a DUT using 4 terminal contacts. In this example, C_d is in parallel with the DUT. When a conductive plate is placed under the DUT, the combined capacitance ($C_h//C_l$) is also in parallel with the DUT, resulting in measurement error. By placing a guard plate between the high and low terminals, C_d can be minimized (Figure 3-12 (b)). Also, by connecting the guard terminal to the conductor, the effects of C_h and C_l can be canceled. In actual measurement setup, the outer shield conductor of coaxial test cables in the 3T, 4T, 5T and 4TP configuration works as the guard terminal. The guarding technique cannot apply to the 2T configuration.

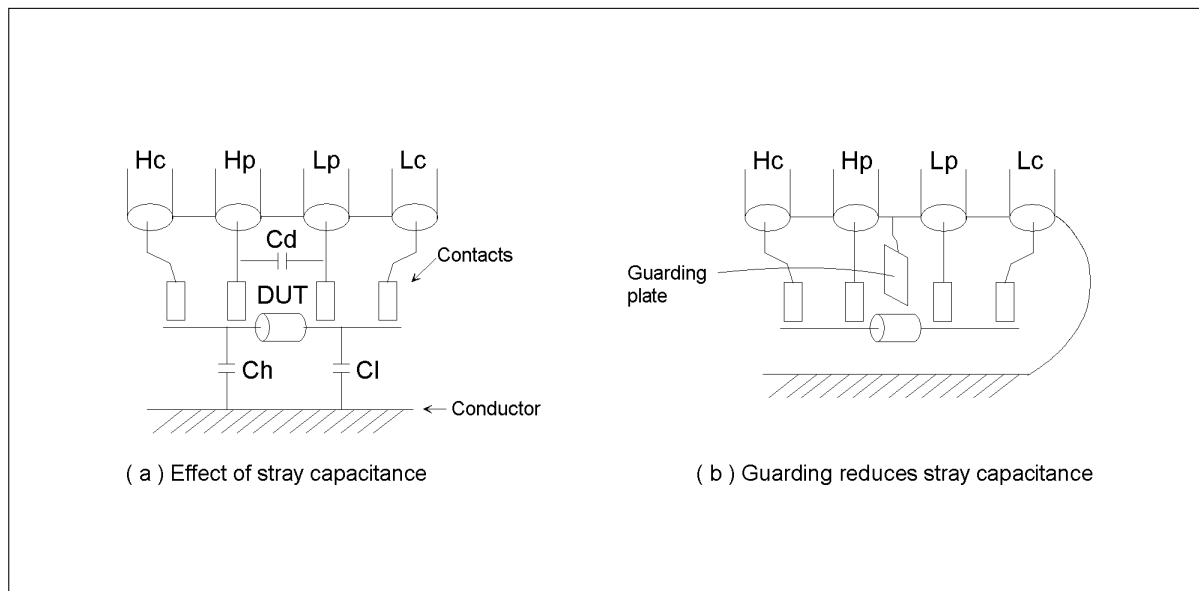


Figure 3-12. Guarding techniques to eliminate the stray capacitance effects

3-6. Terminal configuration in RF region

RF impedance measuring instruments have a precision coaxial test port, which is actually a 2 terminal configuration in principle. The center conductor of coaxial test port connector is active High side terminal and the outer conductor is grounded Low side terminal, as shown in Figure 3-13. To measure the DUT, only the simplest 2-terminal connection configuration can be used. Residual inductance, residual resistance, stray capacitance and stray conductance of the test fixture will add to measurement results (before compensation). Whether the RF I-V method or network analysis, RF impedance measurement has lower accuracy as the measured impedance differs greater from 50Ω . Instrument inaccuracy rather than the error factors in 2-terminal test fixture primarily limits the measurement range. The effect of residuals increases with frequency and narrows the measurable impedance range in very high frequencies.

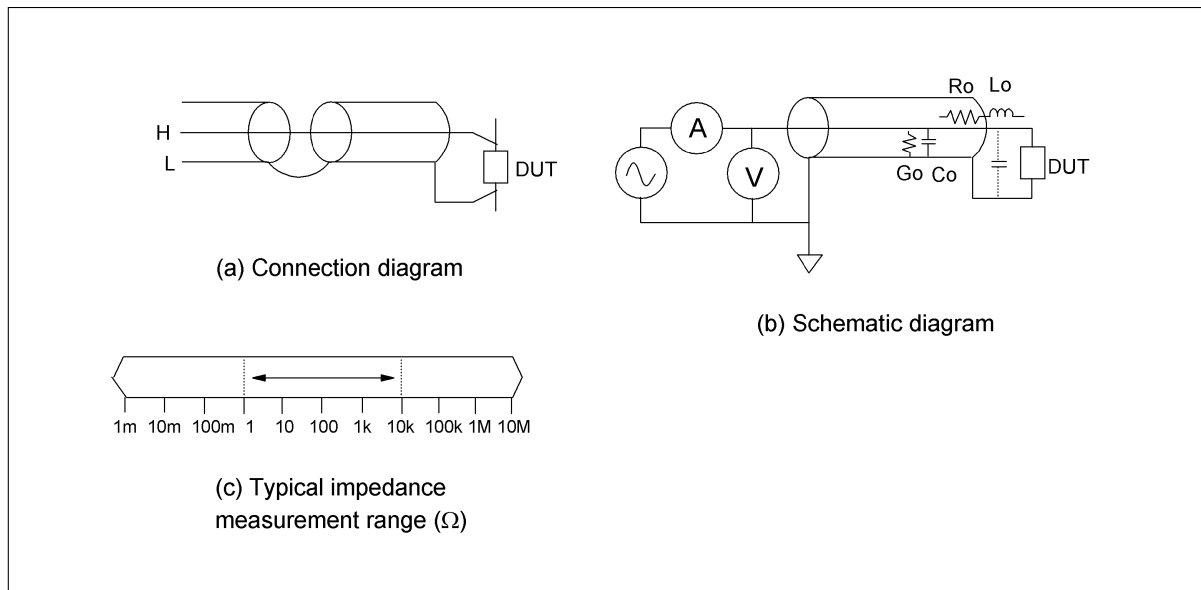


Figure 3-13. Coaxial test port circuit configuration

3-7. RF test fixtures

RF test fixtures are designed so that the lead length (electrical path length) between the DUT and the test port is made as short as possible to minimize residuals. At frequencies typically below 100 MHz, measurement error due to test fixture residuals is small compared to instrument error and is normally negligible after compensation is made. But, especially when measuring low or high impedance close to the residual parameter values, variance in the residuals of the test fixture will cause measurement repeatability problem. For example, when measuring a 1 nH inductor (a very low inductance), a slight variance of 0.1 nH in residual inductance will produce a 10% difference in measured value. The variance in residuals and resultant measurement instability is dependent on the accuracy of positioning the DUT on the test fixture terminals. For repeatable measurements, RF test fixtures should be able to precisely position DUT across measurement terminals.

The test fixture residuals will have greater effects on measurement at higher frequencies (typically above 500 MHz) and will narrow practical measurement range. Therefore, the usable frequency range of the test fixture is limited to the maximum frequency specified for each test fixture. The measurement inaccuracy for the DUT is given by sum of the instrument inaccuracy and the test fixture induced errors. Because only the 2-terminal measurement configuration is available, compensation method is crucial to optimize measurement accuracy. The measurement error sources and compensation techniques are discussed in Section 4.

Each test fixture has unique characteristics and different structure from others. Since not only the residuals but also the surrounding conditions of the DUT (such as ground plate, terminal layout, dielectric constant of insulator, etc.) influence the measured values of the DUTs, the same type of test fixture should be used to achieve good measurement correlation.

3-7-1. Agilent supplied RF test fixtures

Agilent Technologies offers various types of RF test fixtures that meet the type of the DUT and required test frequency range. Consider measurable DUT size, electrode type, frequency, and bias condition to select a suitable test fixture.

There are two types of RF test fixtures: coaxial and non-coaxial test fixtures, which are different from each other for both geometrical structures and electrical characteristics. As the non-coaxial test fixture has open-air measurement terminals as shown in Figure 3-14 (a), it features ease of connecting and disconnecting DUTs. The non-coaxial type is suitable for testing a large number of devices efficiently. Trading off the benefit of measurement efficiency, the measurement accuracy tends to be sacrificed at high frequencies because discontinuity (miss-match) in electrical characteristics exists between the coaxial connector part and the measurement terminals. The coaxial test fixture holds DUT using similar configuration to the coaxial terminations, as shown in Figure 3-14 (b). The DUT is connected across the center electrode and the outer conductor cap electrode of the test fixture. With $50\ \Omega$ characteristic impedance maintained continuously from test port to the DUT, the coaxial test fixture provides the best measurement accuracy and the best frequency response. As the diameter of its replaceable insulator can be selected to minimize the gap between the DUT and the insulator, the DUT can be positioned with a good repeatability across the test fixture's terminals independently of operator skill. The coaxial test fixture ensures less additional errors and much better measurement repeatability than the non-coaxial test fixtures.

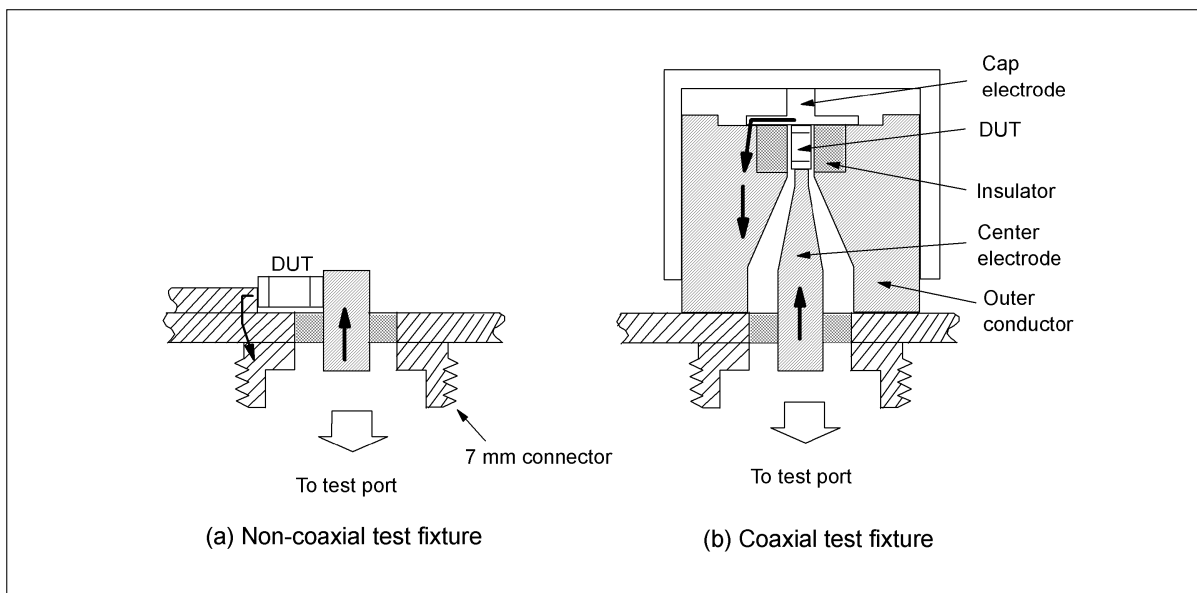


Figure 3-14. Types of RF impedance test fixtures

3-8. Test port extension in RF region

In RF measurements, connect the DUT closely to the test port to minimize additional measurement errors. When there is an unavoidable need of extending the test port, such as in-circuit testing of devices and on-wafer device measurement using a prober, make the length of test port extension as short as possible. If the instrument has a detachable test head, it is better for accuracy to place the test head near the DUT in order to minimize the test port extension length, and interconnect the test head and the instrument using coaxial cables. (Observe the limit of maximum interconnection cable length specified for instrument.) Using a long test port extension will involve large residual impedance and admittance of the extension cable in the measurement results and significantly deteriorate the accuracy even if calibration and compensation are completed.

Figure 3-15 shows an equivalent circuit model of the port extension. The inductance, L_o , resistance, R_o , capacitance, C_o , and conductance, G_o , represent the equivalent circuit parameter values of the extension cable. When the DUT's impedance, Z_x , is nearly $50\ \Omega$, the test signal is mostly fed to the DUT as the cable causes only a phase shift and (relatively small) propagation loss like a transmission line terminated with its characteristic impedance. However, most likely DUTs have different value from $50\ \Omega$. If the impedance of the DUT is greater than that of C_o , the test signal current mainly bypasses through C_o , flowing only a little through the DUT. Conversely, if the impedance of the DUT is lower than that of L_o and R_o , the test signal voltage decreases by voltage drop across the cable and is applied only a little to the DUT. As a result, the cable residuals lead to measurement inaccuracy and instability, particularly, in high impedance and low impedance measurements. As illustrated in Figure 3-15, the L_o , R_o , C_o and G_o not only get involved in the measurement results (before compensation), but also affect measurement sensitivity. Note that the measurable impedance range becomes narrow due to port extension even though the calibration and compensation have been performed appropriately.

In addition, electrical length of the extension cable will vary with environmental temperature and, thereby causing phase measurement instability. Using longer extension makes measurement results more susceptible to the influence of environmental temperature changes. Bending the cable will also cause variance in measured phase angle, deteriorating measurement repeatability. Accordingly, in any applications the port extension should be minimized. Discussion for practical method of extending test port follows.

The RF I-V and network analysis instruments commonly employ an N-type or 7 mm type coaxial connector as the UNKNOWN terminal. Naturally, test port extension is made using a low loss, electrically stable coaxial transmission line (cable) with $50\ \Omega$ characteristic impedance. When choosing the cable, care should be taken for both temperature coefficients of propagation constants and rigidity to restrain the cable from easily bending. Figure 3-16 shows an example when the test fixture is connected at the end of a 7 mm-7 mm cable. Calibration should be performed first at the end of the extension before connecting the test fixture. As the next step the electrical length and open/short compensations for the test fixture can be performed. (Open/short/load calibration may be performed instead of compensation with working standards connected at test fixture's measurement terminals. This method does not require the calibration at the end of the extension.) Detailed discussion for measurement error sources, calibration and compensation is provided in Section 4.

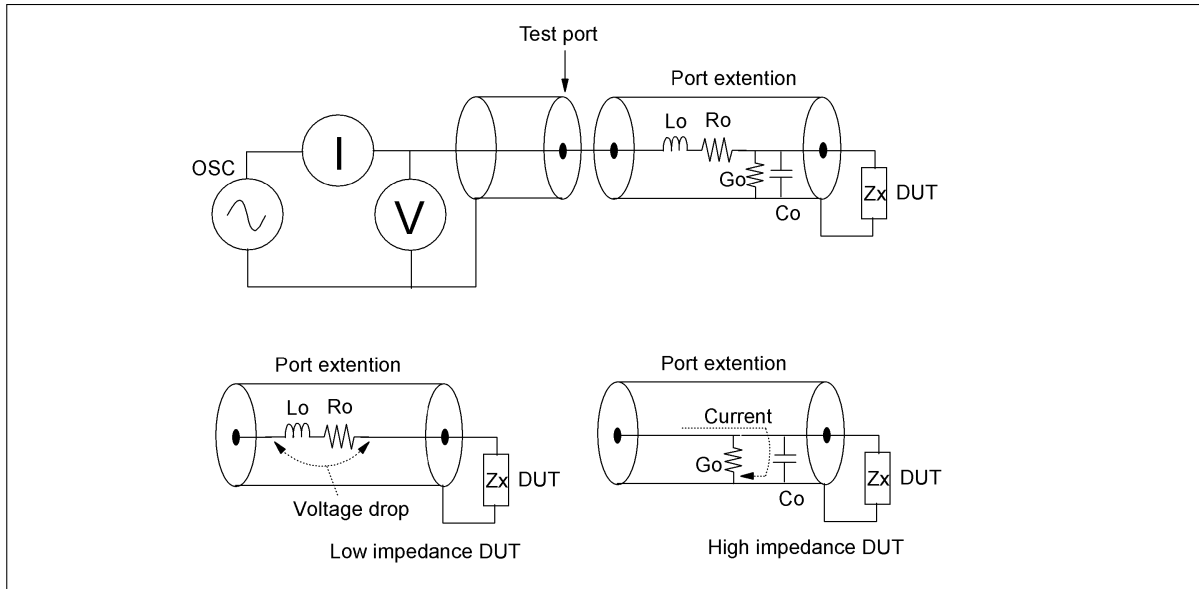


Figure 3-15. Calibration plane extension

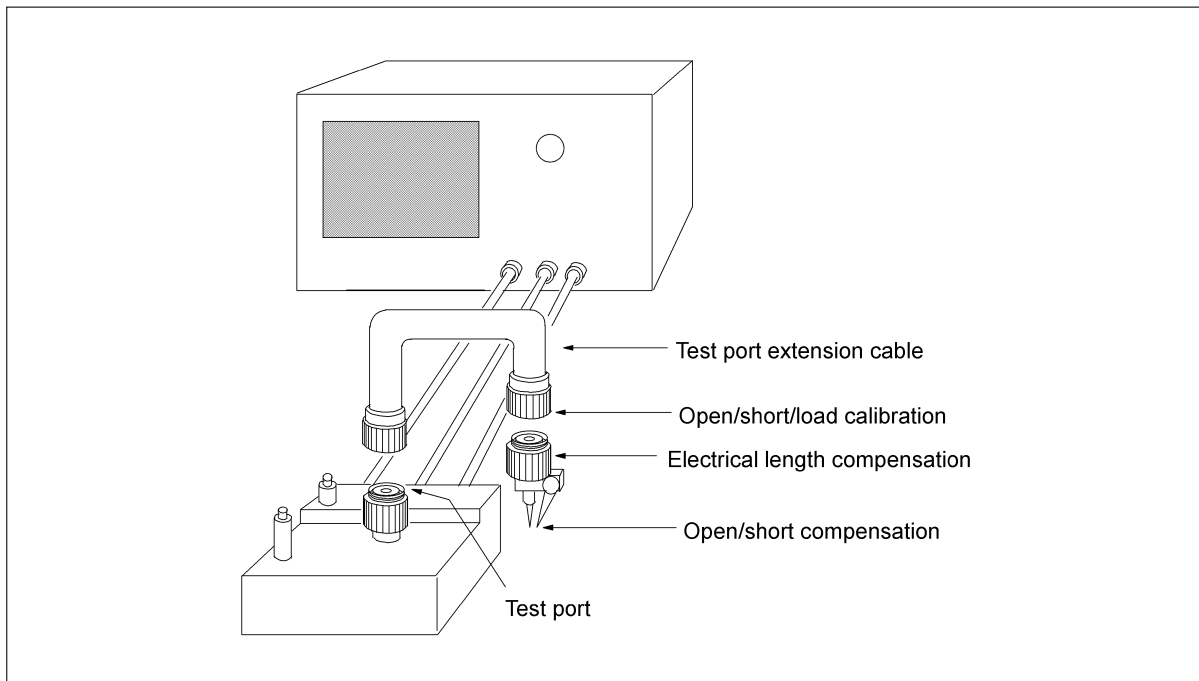


Figure 3-16. Practical calibration and compensation at extended test port

SECTION 4

Measurement error and compensation

4-1. Measurement error

For real-world measurements, we have to assume that the measurement result always contains some error. Some typical error sources are:

- Instrument inaccuracies (including DC bias inaccuracy and OSC level inaccuracy)
- Residuals in the test fixture and cables
- Noise

The DUT's parasitics were not listed because the DUT's parasitics are a part of the DUT and we need to measure the DUT's impedance including its parasitics. In the listed error sources, residuals in the test fixture and test cables can be compensated if they are constant and stable.

4-2. Calibration and compensation

Calibration is to define the “calibration plane”, at which the specified measurement accuracy can be obtained. To calibrate an instrument, “standard devices” are connected at the calibration plane and the instrument is adjusted (through computation/data storage) so that it measures within its specified accuracy. In the case of 4TP configured instruments, the calibration plane is at the UNKNOWN BNC connectors (Figure 4-1).

Compensation reduces the effects of the error sources existing between the DUT and the instrument's calibration plane. Compensation, however, can not always completely remove the error, and the measurement accuracy obtained after compensation is not as good as that obtained at the “calibration plane.” Compensation is not the same as calibration and can not replace calibration, the measurements required for compensation depend on the calibration accuracy of the instrument, so compensation must be performed after calibration has been completed. Compensation improves the effective measurement accuracy of an instrument. The following paragraphs describe three commonly used compensation techniques.

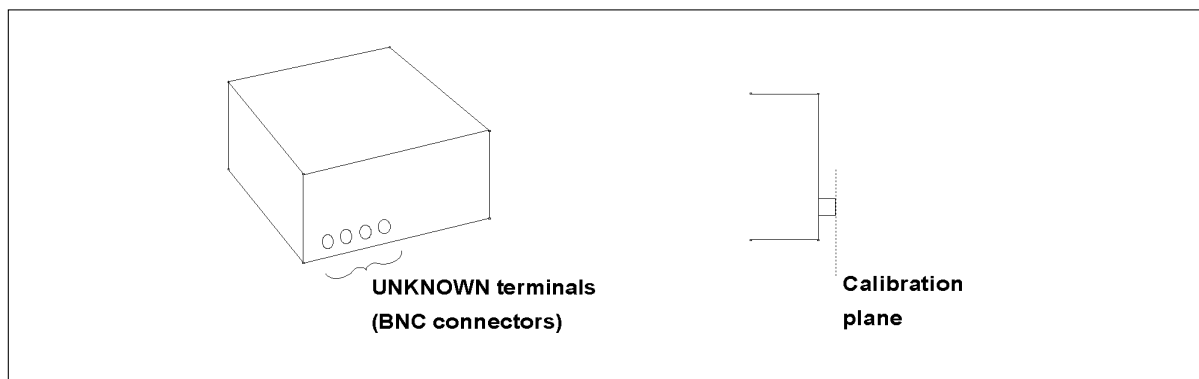


Figure 4-1. Calibration plane of 4TP instrument

4-2-1. Offset compensation

When a measurement is affected by only a single component of the residuals, the effective value can be obtained by simply subtracting the error value from the measured value. For example, in the case of the low value capacitance measurement shown in Figure 4-2, the stray capacitance C_o paralleled with the DUT's capacitance C_x is significant to the measurement and can be compensated by subtracting the stray capacitance value from the measured capacitance value C_m . The stray capacitance value is obtained with the measurement terminals left open.

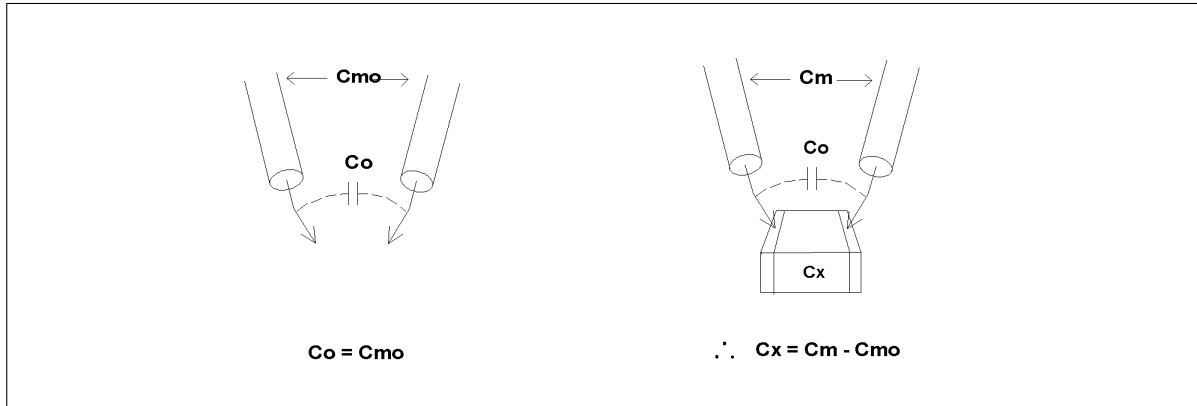


Figure 4-2. Offset compensation

4-2-2. Open and short compensations

Open and short compensations are the most popular compensation technique used in recent LCR measurement instruments. This method assumes that the residuals of the test fixture can be represented by the simple L/R/C/G circuit. The method is represented in Figure 4-3 (a). When the UNKNOWN terminals are open, as shown in Figure 4-3 (b), stray admittance $G_o + j\omega C_o$ is measured as Y_o because residual impedance Z_s is negligible. When the UNKNOWN terminals are shorted, as shown in Figure 4-3 (c), the measured impedance represents residual impedance $Z_s = R_s + j\omega L_s$ because Y_o is bypassed. As a result, each residual parameter is known and, the DUT's impedance, Z_{dut} , can be calculated from the equation given in Figure 4-3 (d).

Note: Agilent's impedance measurement instruments actually use a slightly different equation. Refer to APPENDIX B for more detailed information.

This compensation method can minimize the errors when the actual residual circuit matches the assumed model in the specific situations listed below:

- Measurement by connecting an Agilent test fixture to the UNKNOWN terminals
- Measurement with an Agilent test fixture connected by an Agilent test cable that is compensated for electrical length

In other situations, the open/short compensation will not thoroughly correct the measured values. In addition, this method cannot correlate measurement results from different instruments. To resolve these compensation limitations, the open, short and load compensations are required. Refer to Paragraph 4-2-4 for details.

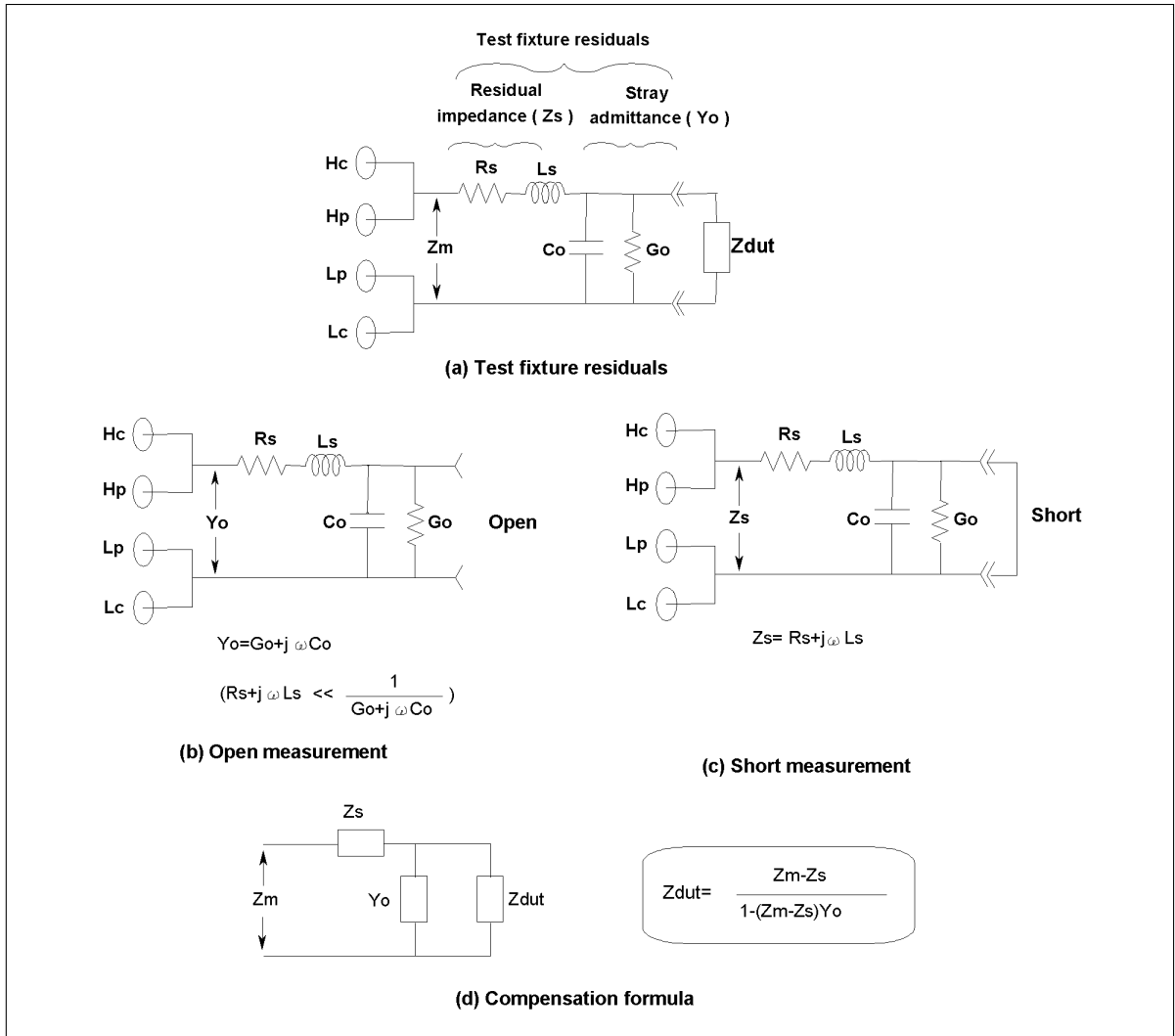


Figure 4-3. Open/short compensation

4-2-3. Precautions for open and short measurements

When an open measurement is made, it is important to accurately measure the stray capacitance. To do this, keep the distance between the test fixture terminals the same as when they are holding the DUT, set the integration time, averaging, and OSC level so that the instrument measures with maximum accuracy. If an open measurement is performed under improper conditions, stray admittance Y_o is not correctly measured, resulting in measurement error.

Short measurement is performed by connecting the test fixture terminals directly together or by connecting a shorting device to the terminals. The residual impedance contained in the shorting device should be much lower than the DUT's impedance, otherwise it will directly affect the measurement results. Figure 4-4 shows an example of a shorting device that is applicable to the 16047A, 16047C and 16047D test fixtures. This shorting bar (Agilent PN: 5000-4226) typically has residuals of 20 nH and 1 mΩ. Hence, the shorting bar is not suitable for low impedance measurement. For very low impedance measurement, you should use a test fixture in which the fixture terminals can be connected directly together.

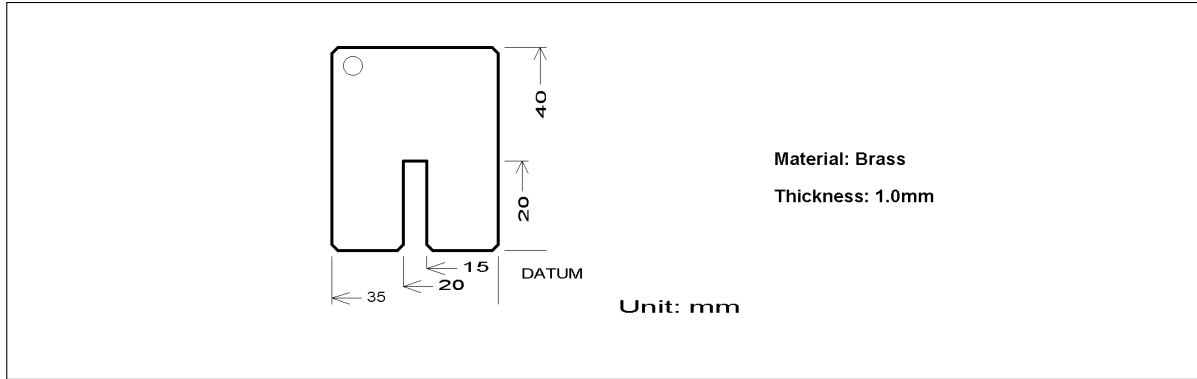


Figure 4-4. Example of shorting device. (Agilent PN: 5000-4226)

4-2-4. Open, short and load compensations

There are numerous measurement conditions where complicated residual parameters cannot be modeled as the simple equivalent circuit in Figure 4-3. Open/short/load compensation is an advanced compensation technique that is applicable to complicated residual circuits. To perform open/short/load compensation, three measurements are required before measuring the DUT, with the test fixture terminals opened, shorted, and with a reference DUT (load) connected. These measurement results (data) are used for calculation when the DUT is undergoing measurement. As shown in Figure 4-5, the open/short/load compensation models the test fixture residuals as a four-terminal network circuit represented by the ABCD parameters. Each parameter is known if three conditions are known and if the four-terminal circuit is a linear circuit.

The open/short/load compensation should be used in the following situations:

- (1) An additional passive circuit or component (e.g. external DC bias circuit, balun transformer, attenuator and filter) is connected.
- (2) A scanner, multiplexer or matrix switch is used.
- (3) A non-standard length test cable is used or the 4TP cable is extended from the standard Agilent test cable.
- (4) An amplifier is used to enhance test signal.
- (5) A component handler is used.
- (6) A custom-made test fixture is used.

In the cases listed above, open/short compensation will not work effectively and the measurement result contains some error.

It is not necessary to use open/short/load compensation for simple measurement, like measuring an axial leaded component using the 16047A test fixture. Open/short compensation is adequate for such measurements.

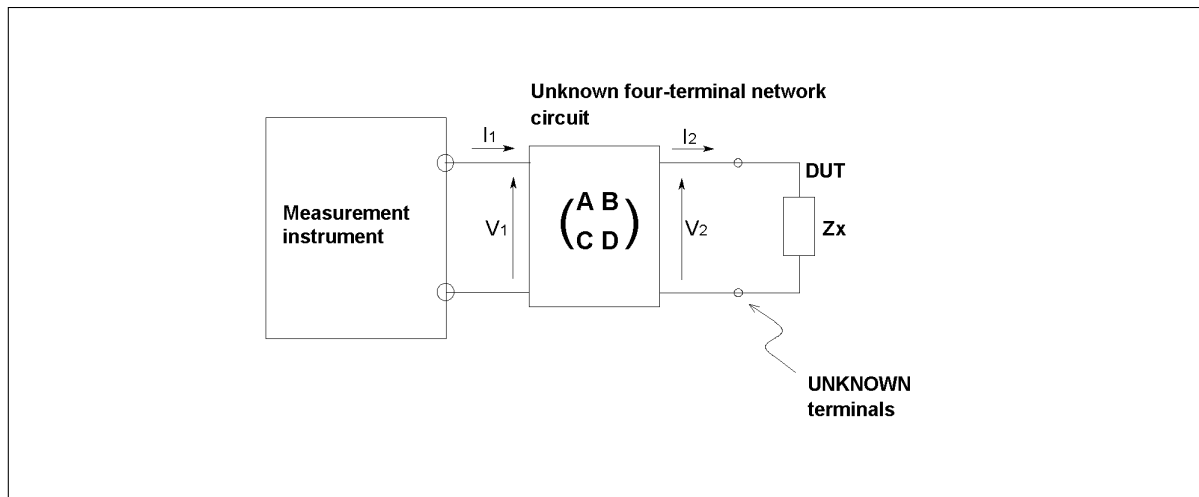


Figure 4-5. Open/short/load compensation

4-2-5. What should be used as the load?

The key point in open/short/load compensation is to select a load whose impedance value is accurately known. The criteria is as follows.

Use a stable resistor or capacitor as the load device. The load device's impedance value must be stable under conditions of varying temperature, magnetic flux, and other component dependency factors. So, avoid using inductors which are relatively sensitive to measurement conditions, for the load.

Use a load of same size and measure it in the same way as the DUT will be measured. As shown in Figure 4-6, if the load is measured under different electrode conditions, its measured data will not effectively compensate the residuals. It is a good idea to use one of the actual DUTs as a working standard. If the load is a different type from the DUT (e.g. load is C and DUT is R), at least keep the same distance between the electrodes.

Use a load that is close in value to the DUT. Whatever the load value is, the load compensation is effective over the entire measurement range if the measurement circuit has a linear characteristic. In practice, the circuit between the UNKNOWN terminals and the DUT may have a non-linear factor, especially when an additional circuit includes a non-linear component such as an inductor, active switch, amplifier, etc.. As shown in Figure 4-7, additional measurement error will be added when the measured DUT value is far from the load value used for the compensation. So, the impedance value of the load should be as close as possible to that of the DUT to be measured. If various impedances are to be measured, select a load that is nearly the center value of the DUT's impedance range. In addition, the load value should not be near the open or short impedance. Otherwise, the load compensation will not be effective and the result of the open/short/load compensation will be much the same as (or even worse than) that of open/short compensation.

Use an accurately known load value. The impedance value of the load must be known before performing the open/short/load compensation. To measure the load value, it is practical to use the same measurement instrument, but under the best possible measurement conditions. Set the

measurement time, averaging and OSC level so that the instrument can measure the load with maximum accuracy. Also, use a test fixture which mounts directly to the instrument. Figure 4-8 shows an example of such a measurement.

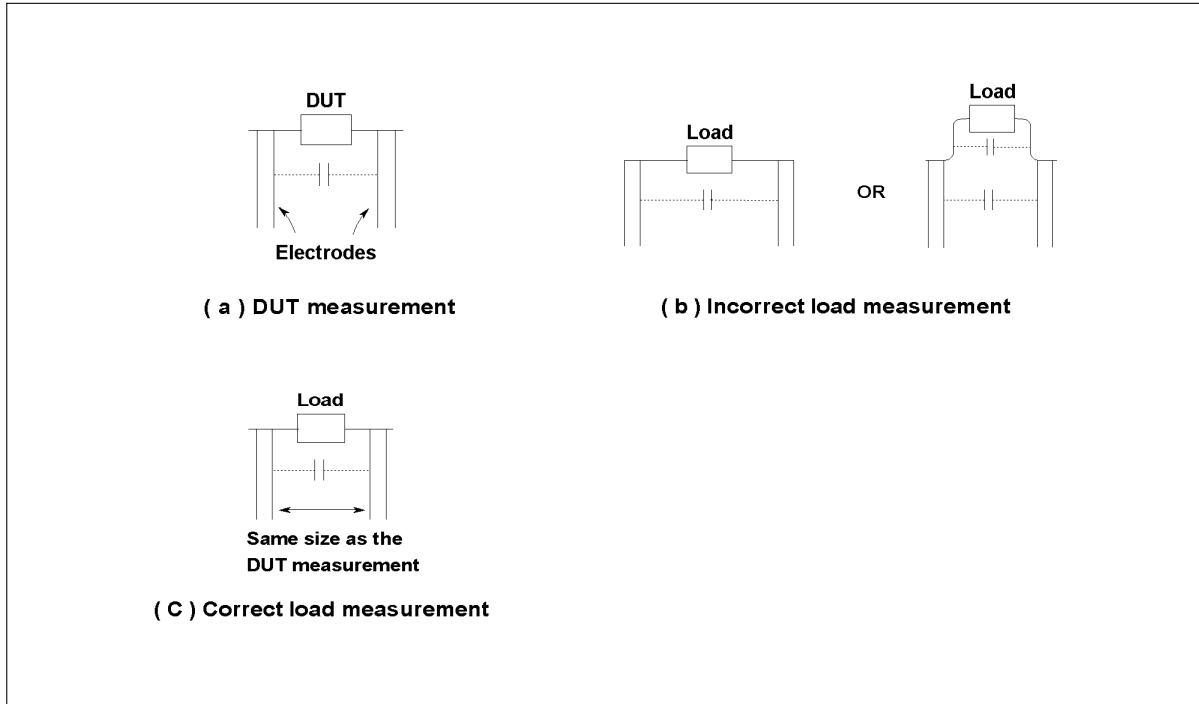


Figure 4-6. Electrode distance in load measurement

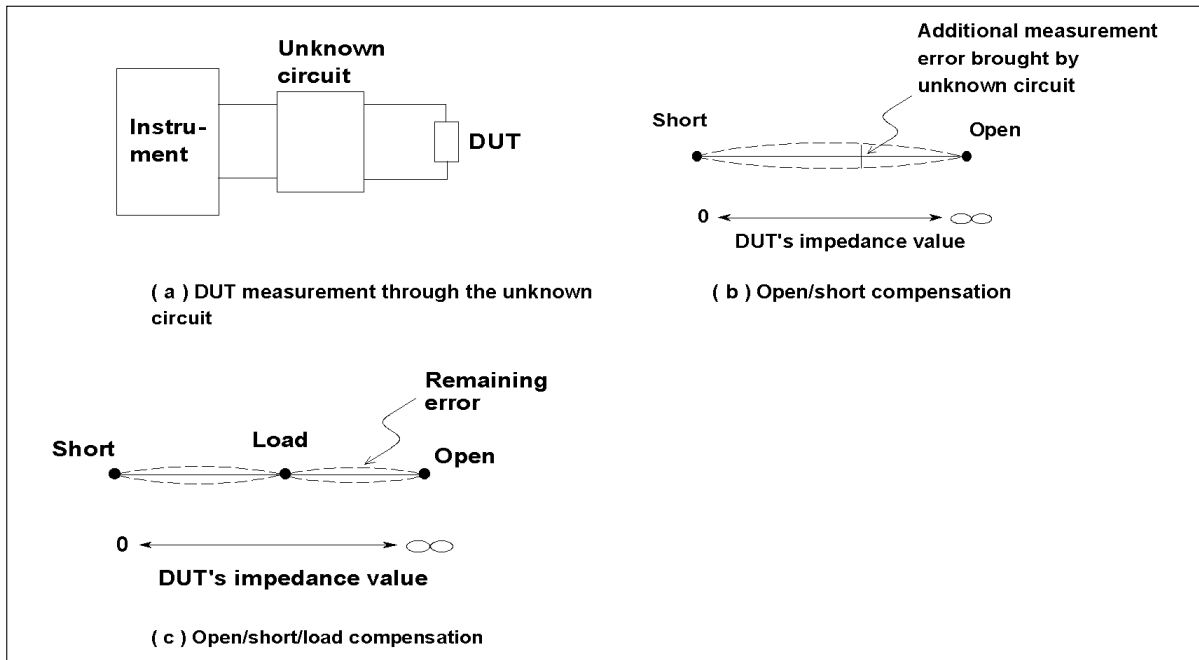


Figure 4-7. Load value must be close to DUT's value

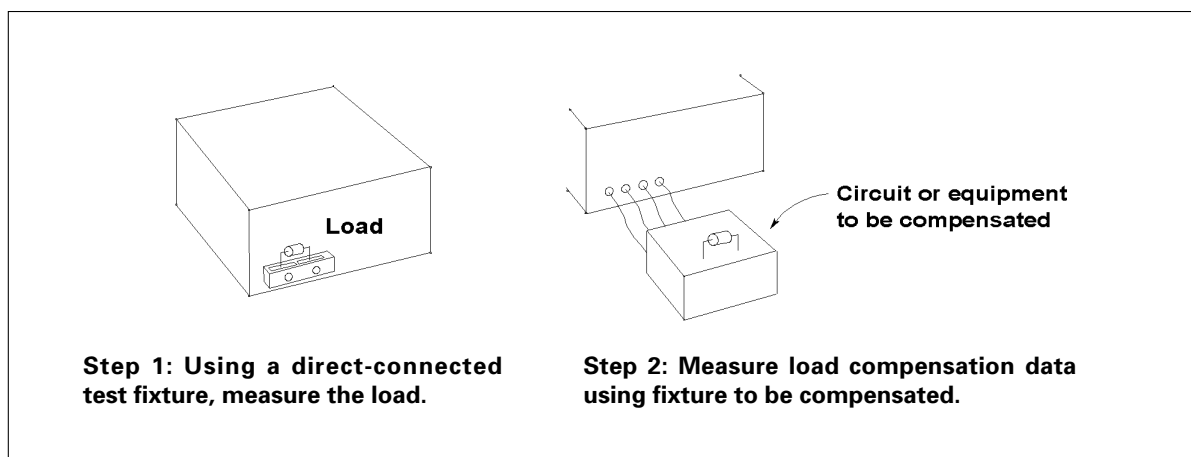


Figure 4-8. Actual open/short load measurement example

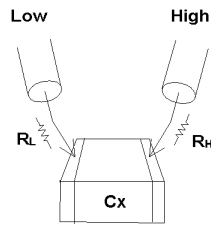
4-2-6. Application limit for open, short and load compensations

When the residuals are too significant compared to the DUT's impedance value, compensation may not work properly. For example, if the measured short impedance Z_{sm} is about the same as DUT's impedance, total measurement error will be doubled. The following are typical criteria for this limitation:

- (1) Measured open impedance Z_{om} must be more than 100 times that of the DUT's impedance.
- (2) Measured short impedance Z_{sm} should be less than 1/100 that of the DUT's impedance.

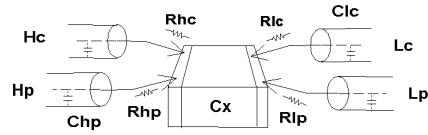
4-3. Error caused by contact resistance

Any contact resistance existing between the DUT electrodes and the contact electrodes of the test fixture or test station will result in measurement error. The effects of the contact resistance are different for the DUT connection methods, 2-terminal and 4-terminal. In the case of a 2-terminal connection, the contact resistance is added to the DUT impedance in series and produces a positive error in D (dissipation factor) reading (Figure 4-9 (a)). In the case of a 4-terminal connection, contact resistances R_{hc} , R_{hp} , R_{lc} and R_{lp} exist as shown in Figure 4-9 (b). The effects of the contact resistance differ depending on the terminals. R_{hc} decreases the test signal level applied to the DUT, but it does not directly produce measurement error. R_{lp} may cause the auto balancing bridge to be unstable, but generally its effect is negligible. R_{hp} and C_{hp} (distributed capacitance of the coaxial test lead) form a low-pass filter, which causes attenuation and phase shift of the H_p input signal, producing measurement error. R_{lc} and C_{lc} also form a low-pass filter and cause an error in measured DUT current and phase angle. Since the resultant dissipation factor error is proportional to $-\omega R_{hp} \times C_{hp}$ and $-\omega R_{lc} \times C_{lc}$, the D error is a negative value and increases with frequency. This error becomes significant when the 4-terminal connection method is used in high frequency measurements. The 4-terminal connection gives a constant D error (that is determined by the contact resistance and test lead capacitance only) while the error of the 2-terminal connection varies depending on the DUT's value (Figure 4-9 (c)). The 4-terminal connection provides minimal error only when the effects of contact resistance and test lead capacitance are negligible (mainly at low frequencies).



$$\text{D error} = \omega C_x (R_L + R_H)$$

(a) Contact resistance in 2-terminal connection



Error caused by Rhp with Chp:

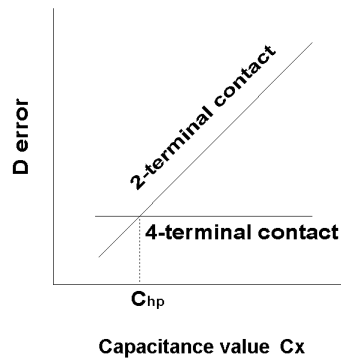
$$\text{Magnitude error: } \frac{1}{\sqrt{1 + \omega^2 C_{hp}^2 R_{hp}^2}} - 1$$

$$\text{Phase error: } \omega C_{hp} R_{hp} \text{ (rad)}$$

Error caused by Rlc with Clc:

$$\text{D Error} = -\omega (C_{hp} R_{hp} + C_{lc} R_{lc})$$

(b) Contact resistance in 4-terminal connection



(c) Error of 2-terminal and 4-terminal connections

If $R_H = R_L = R_{hp} = R_{lc}$ and $C_{hp} = C_{lp}$, D errors of 2-terminal and 4-terminal become the same when $C_x = C_{hp}$

This means that the 2-terminal connection is a better choice when the DUT capacitance is smaller than cable capacitance (C_{hp} or C_{lc}).

Figure 4-9. Effect of contact resistance

4-4. Measurement cable extension induced error

Extending a 4TP measurement cable from the instrument will cause a magnitude error and phase shift of the measurement signal according to the extension cable length and measurement frequency.

The following two problems will arise from the cable extension:

- (1) Error in impedance measurement result
- (2) Bridge unbalanced

The measurement error is mainly caused by the cable connected to the Hp and Lc terminals, and it can be compensated by the instrument if the cable length and propagation constants of the cable are known (refer to Figure 4-10). Bridge unbalance is caused by the phase shift in the feedback loop that includes the R_r , amplifier, and the Lp and Lc cables. This can be compensated by an intentional phase shift in the feedback loop. These two problems are critical only at frequencies higher than 100 kHz, and Agilent's impedance measurement instruments can compensate for Agilent-supplied test cables. In the frequency region lower than 100 kHz, the capacitance of the cable will only degrade the measurement accuracy (but does not affect the bridge balance). This effect of cable extension is shown in Figure 4-11.

Note: Cable length and electrical length are different and should not be confused.

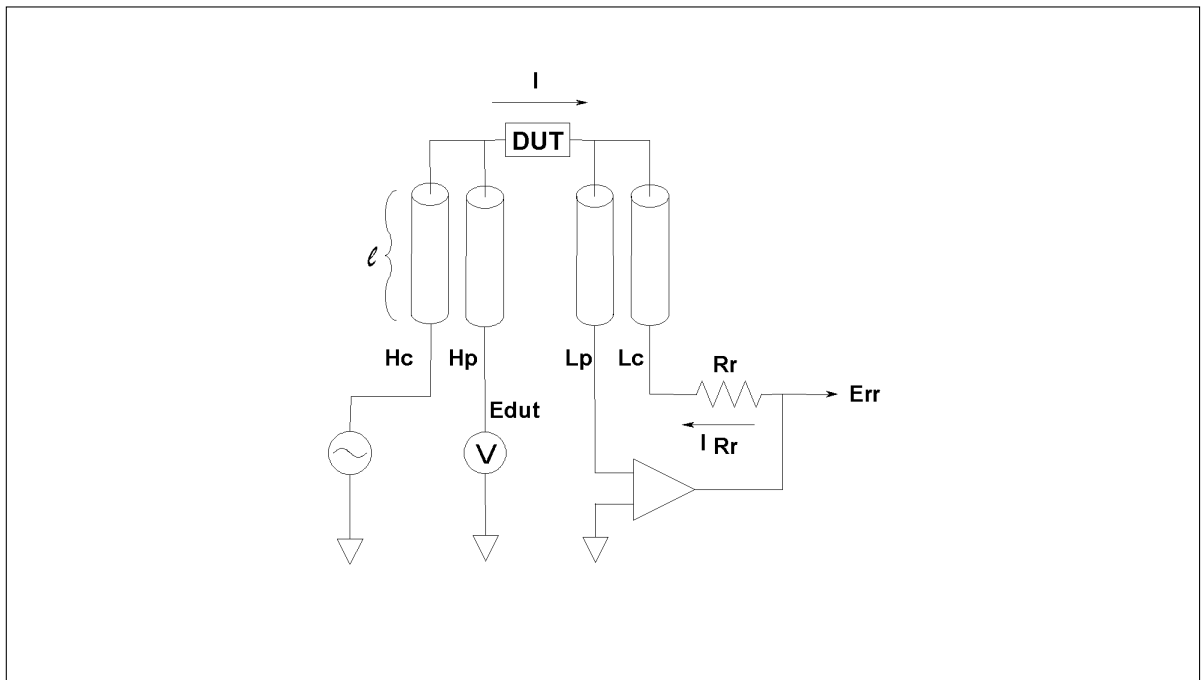


Figure 4-10. Cable length compensation

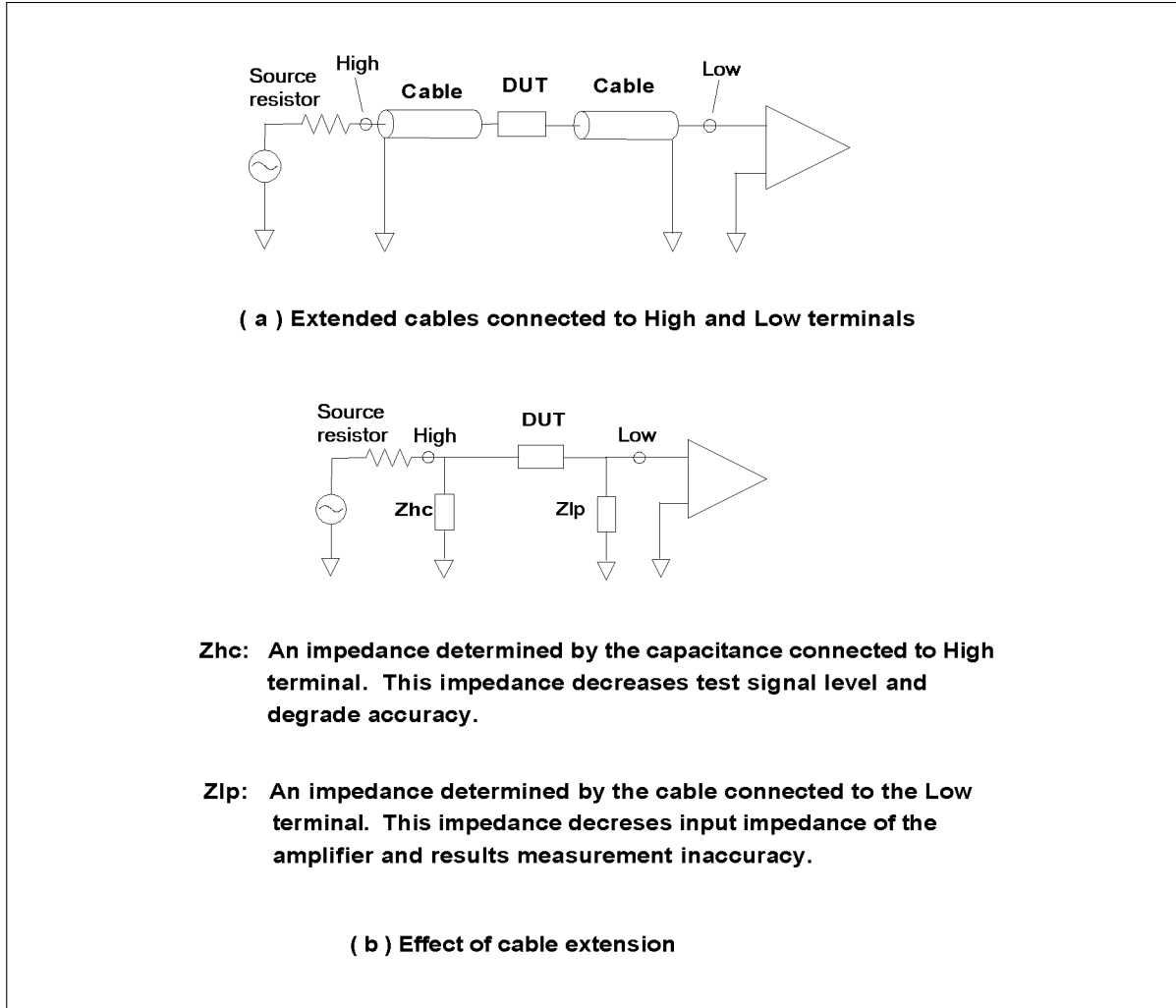


Figure 4-11. Measurement error due to extended cable length

The cable length compensation works for test cables whose length and propagation constants are known, such as the Agilent-supplied test cables of 1 m (2 m or 4 m). If different types of cable in different lengths are used, it may cause bridge unbalance in addition to measurement error.

In practice, the measurement error is different for the cable termination types of the instrument; that is, wide-frequency 4TP instruments that internally terminate cables with its characteristic impedance differ from general 4TP instruments without cable termination. A measurement error in case of no termination is discussed first, and the case of terminated cables follows.

(1) Cable extension without termination

Extending test cable from the 4TP instrument without cable termination will produce an impedance measurement error, which is typically given by the following equation:

$$\text{Error} = k \times \Delta L \times f^2 (\%)$$

Where, k : A coefficient specific to the instrument,
 ΔL : Cable length difference (m) from 0 m or 1 m,
 f : Measurement frequency (MHz)

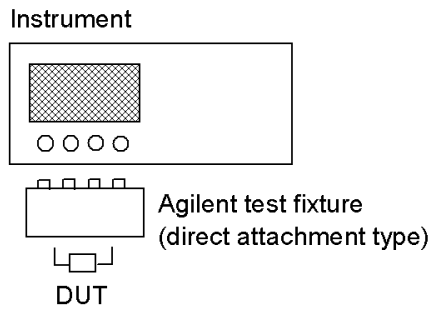
k value is a decimal number mostly within the range of -1 to +1 and different for different instruments. As the above equation shows, the error rapidly increases in proportion to square of measurement frequency. Using open/short compensation will not reduce this error. Only open/short/load compensation can minimize this error.

(2) Cable extension with termination

Extending the test cables from the instrument with cable termination will not produce a large error for the magnitude of measured impedance, but cause a phase error in proportion to the extension length and measurement frequency. (In practice, an error for the magnitude of impedance also occurs because the actual cable termination is not ideal.) Performing the open/short/load compensation at the end of the cable can eliminate this error.

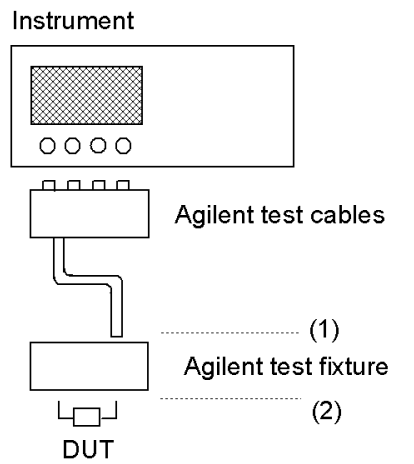
4-5. Practical compensation examples

The error sources present in a practical measurement setup are different for the configuration of test fixtures, test cables or circuits which may be connected between the instrument and the DUT. Appropriate compensation methods need to be applied depending on the measurement configuration used. The Figure 4-12 shows examples of the compensation methods that should be used for typical measurement setups.

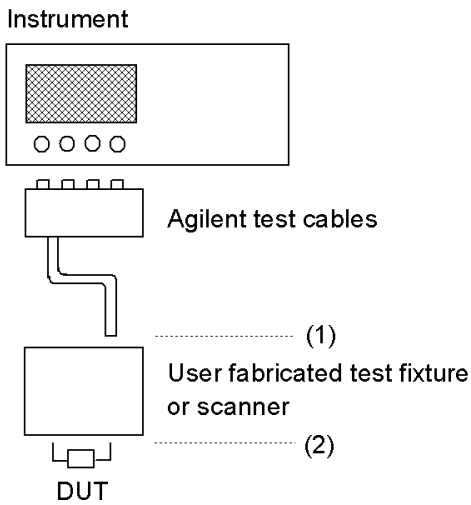


Open/short compensation

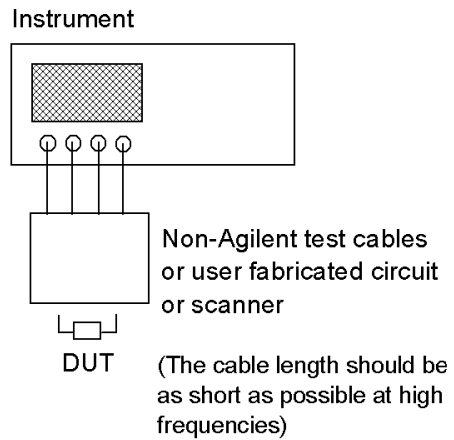
(When using the 16034G/H, open/short/load compensation is recommended for a measurement above 3 MHz)



- (1) Cable length compensation
- (2) Open/short compensation



- (1) Cable length compensation
- (2) Open/short/load compensation



Open/short/load compensation

Figure 4-12. Compensation examples

4-6. Calibration and compensation in RF region

4-6-1. Calibration

Whether the RF I-V method or network analysis, the open, short and load calibration minimizes instrument inaccuracies. To perform calibration, open, short and load reference terminations are connected to the test port and, each of the terminations is measured. This calibration data is stored in instrument memory and used for calculation to remove the instrument errors. Impedance values of these reference terminations are indicated in both vector impedance coordinates and smith chart in Figure 4-13.

Note: A 7 mm coaxial connector has a fringe capacitance of typically 0.082 pF when terminated with open. This fringe capacitance value has been memorized in the instrument and is used to calculate accurate open calibration data.

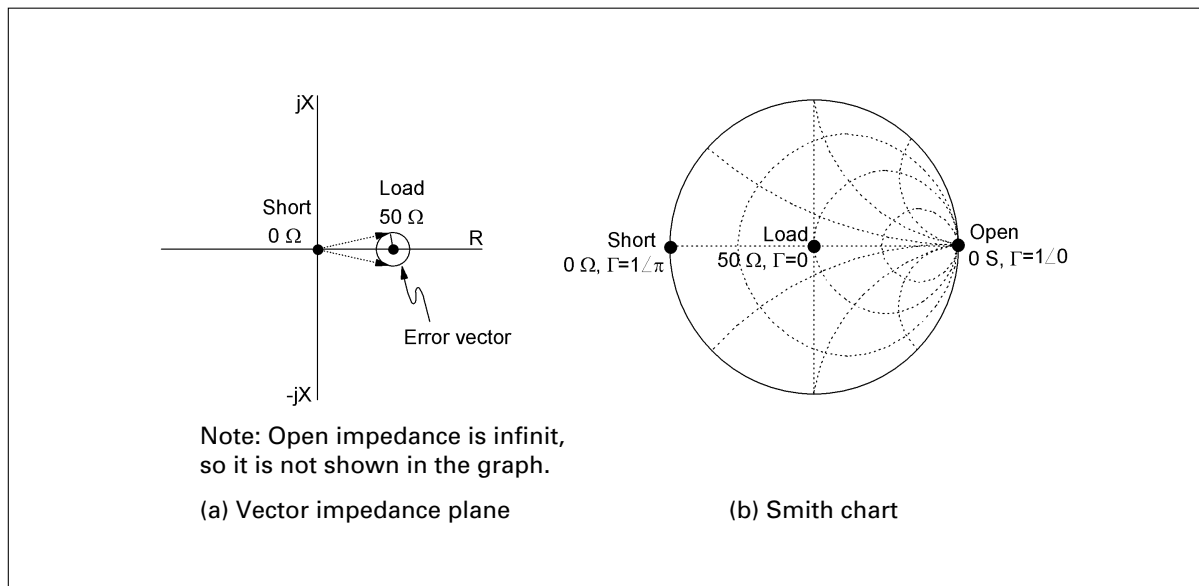


Figure 4-13. Calibration standard values

Though all three terminations are indispensable for calibration, the load termination impedance (50Ω) is particularly important for precise calibration and has a large influence on resultant measurement accuracy. The uncertainty of the load termination impedance is represented by a circle that encloses the error vector. See Figure 4-13 (a) for a demonstration. The uncertainty of its phase angle increases with frequency and becomes a considerable error factor, especially, in measurements of high Q (low ESR or low D) devices at high frequencies.

To improve accuracy for the high Q (low loss) measurement, the RF I-V measurement instrument can be calibrated using a low loss capacitor (LLC) termination in addition to the open/short/load terminations. The LLC provides a reference for calibration with respect to 90° -phase component of impedance. As a result, the instrument can measure high Q (low dissipation factor) devices more accurately than in case of basic open/short/load calibration. The LLC calibration takes place only in high frequency range (typically above 300 MHz) because the phase angle of the load impedance is accurate at relatively low frequencies.

When the test port is extended, calibration should be performed at the end of extension cable, as discussed in section 3. Thereby, the calibration plane is moved to the end of cable.

To perform measurements met to specified accuracy, the instrument should be calibrated before measurement is initiated and each time the frequency setting is changed. The calibration defines the calibration reference plane at which measurement accuracy is optimized.

If a component could be measured directly at the calibration plane, it would be possible to obtain measured values within the specified accuracy of the instrument. However, the real-world components cannot be connected directly to the calibrated test port and, a suitable test fixture is used for measurements. Calibration is not enough to measure the DUT accurately. Because measurement is made for the DUT connected at the contact terminals of the test fixture (different from calibration plane), the residual impedance, stray admittance and electrical length that exist between the calibration plane and the DUT will produce additional measurement errors. As a result, compensation is required to minimize those test fixture induced errors.

4-6-2. Error source model

Regarding ordinary non-coaxial test fixtures, consider an error source model similarly to that in low frequency measurements. Figure 4-14 (a) illustrates typical test fixture configuration and a model of error sources. The test fixture is configured with two electrically different sections: A coaxial connector section and a non-coaxial terminal section for connecting DUT. The characteristic of the coaxial section can be modeled using an equivalent transmission line (distributed constant circuit) and represented by propagation constants. Normally, as the coaxial section is short enough to neglect the propagation loss, we can assume that only the phase shift (error) expressed as electrical length exists. The characteristic of the non-coaxial section can be described using the residual impedance and stray admittance model in two-terminal measurement configuration as shown in Figure 4-14 (b). We can assume residual impedance, Z_s , in series with DUT and stray admittance, Y_o , in parallel with DUT.

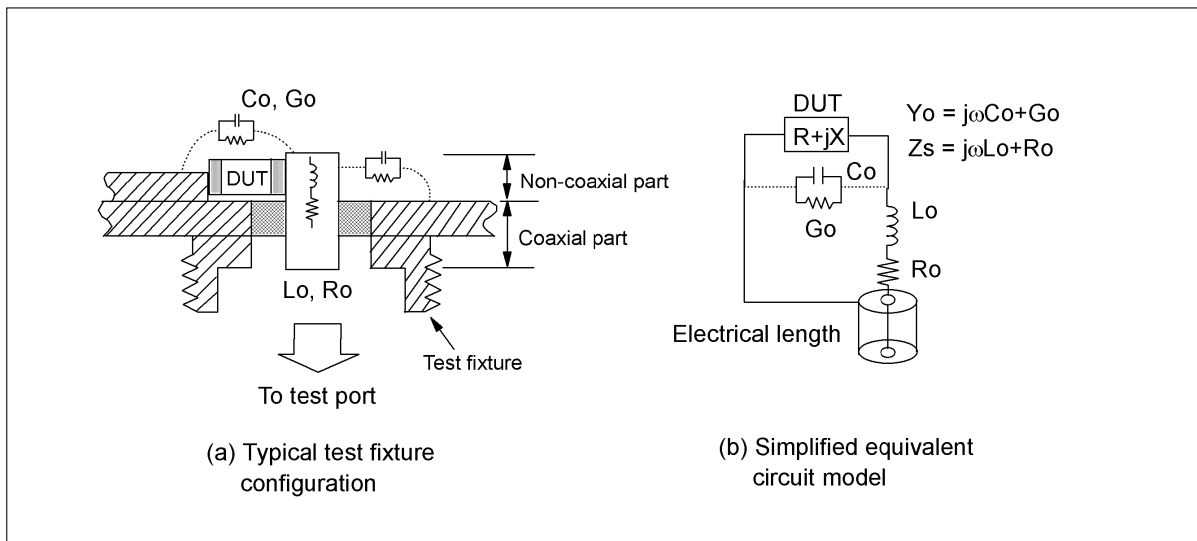


Figure 4-14. Typical error source model

4-6-3. Compensation method

As the error source model is different for the coaxial and non-coaxial sections of the test fixture, compensation method is also different for each of them.

Electrical length compensation eliminates measurement errors induced by the phase shift in the coaxial section. Agilent RF impedance analyzers and RF LCR meters facilitate the electrical length compensation by allowing you to choose the model number of desired test fixture from among the displayed list, instead of entering the specified electrical length of that test fixture to the instrument. (It is also possible to input the specified electrical length value.)

Open/short compensation is effective for residuals in the non-coaxial section. It is based on the same compensation theory as described for low frequency measurements. (Refer to paragraph 4-2-2 for details.) The Y_o and Z_s can be known by measuring with the contact terminals opened and shorted, respectively.

As the test fixture is configured with the coaxial and non-coaxial sections, both compensations are required to minimize combined errors. Load compensation is not required for normal measurements using Agilent supplied test fixtures.

When a test port extension or a user-fabricated test fixture is used, error sources will not match the model assumed for the open/short compensation and affect measurement results. In such cases that measurement errors cannot be sufficiently removed, consider attempting the open/short/load compensation. Actually, the open/short/load compensation is substituted by the open/short/load calibration using working-standard devices because these two functions are equivalent to each other. Note that when the open/short/load calibration is executed at measurement terminals, the test port calibration data is invalidated (because the calibration plane is moved.) Consequently, measurement accuracy depends on the calibrated accuracy of the short and load working standard devices (open calibration requires no device) as well as proper contact when these standard devices are inserted into the test fixture. It is important to take special consideration for the precision of the standard values, contact resistance and positioning of the standard device on the test fixture.

4-6-4. Precautions for open and short measurements in RF region

To discuss calibration and compensation issues, we need to consider how residual parameters have large effects on measurement results at high frequencies.

Assume that, for example, a residual inductance of 0.1 nH and a stray capacitance of 0.1 pF exist around the measurement terminals of the test fixture. Notice how the effects of these small residuals differ depending on frequency. Relationships of the residual parameter values to the typical impedance measurement range are graphically shown in Figure 4-15. In low frequency region, the residual parameter values are much smaller than the values of normally measured devices. It is because the capacitors and inductors, which are designed for use in low frequency electronic equipment, possess large values compared to small residuals. In high frequency region, however, such devices as which are employed for higher frequency circuits and equipment have lower values. In the frequency range typically above 100 MHz, the majority of the DUTs are low value devices (in the low nanohenries and the low picofarads) and their values come closely to the values of the residuals.

Accordingly, the residual parameters have greater effects on higher frequency measurements and become a primary factor of measurement errors. The accuracy of measurement results after compensation depends on how the open/short measurements have been performed properly.

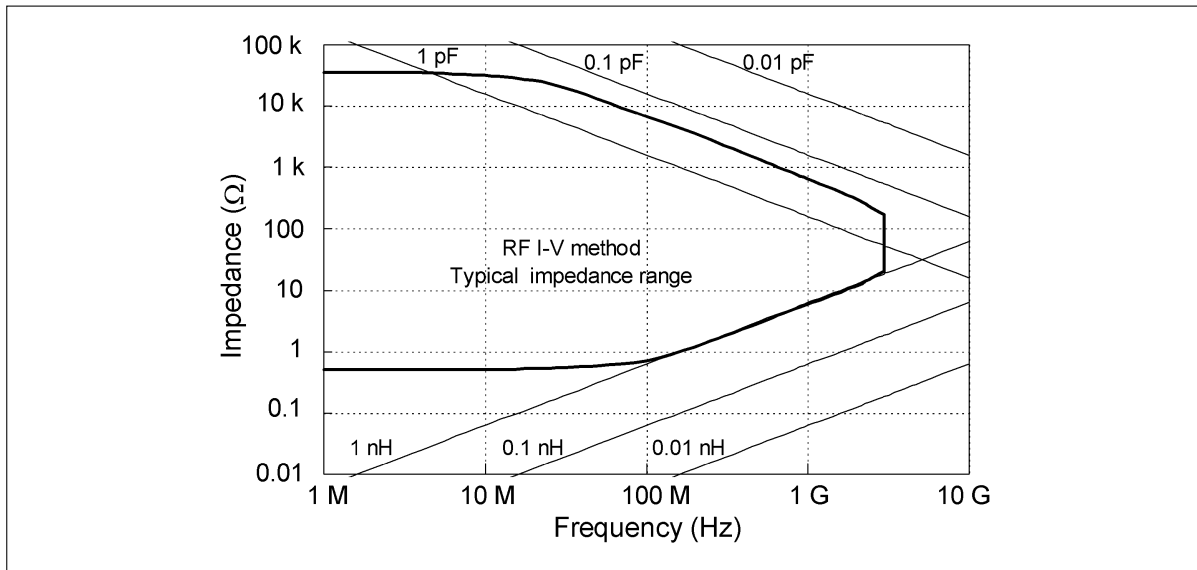


Figure 4-15. Relationship of residual parameter values to the typical impedance measurement range of the RF I-V method

To perform optimum compensation, observe the precautions for open/short measurements as described in paragraph 4-2-3. In high frequency region, the method of open/short compensation dominates measurement correlation. To obtain measurement results with a good correlation and repeatability, the compensation must be performed at the same conditions. A difference in compensation method will result in a difference in measured values, leading to correlation problems on measurement results. Short measurement is more critical in terms of increasing need for low inductance measurements. The short compensation issue is discussed in the following paragraph.

4-6-5. Consideration for short compensation

To make short measurement at the contact terminals of a test fixture or of a component handler, a short bar (chip) is usually employed. In measurement of very low impedance (inductance), the following problems arise from the short bar:

- Different residual impedance dependent on size and shape
- Method of defining the residual impedance

If a different size or shape of the short bar is used, it is difficult to attain a good correlation of the measurement results. The residual impedance of the short bar is different if the size differs. Hence, the same size of short bar must be used when making short measurement.

If the definition of the short bar's impedance is different, it causes a difference in measured values. To have a good correlation, it is desirable to determine the short bar's residuals. However, it cannot be determined only from the inherent impedance of the short bar itself. The actual impedance depends on surrounding conditions such as contact terminals, thickness of the closely located conductors, permittivity of insulators, ground conditions, etc.

Conceptually, there are two methods of defining the short bar's impedance: One is to assume the impedance to be zero. This has been a primordial method of defining the short impedance. In this definition method, measurement result is a relative value of the DUT to the short bar.

The other method is to define the short bar's inductance as xx H. (Residual resistance is negligible for small short bar.) In this method, the measurement result is deemed as the absolute value of the DUT. The residual inductance of the short bar is estimated from physical parameters (size and shape) and is used as a reference. To estimate the inductance, the short bar needs to meet conditions, where theoretical derivation is possible.

The measurement results from both definition methods are correct. The difference in measurement result is attributable to only the difference in the definition. Practically, because of these incompatible definitions, a problem will emerge when yielding correlation. To avoid this type of problem, it is necessary to establish an agreement on the short bar's size, shape and the definition method of the residual inductance.

Note: Each of the 16196A/B/C coaxial test fixtures has a short device whose value is theoretically definable. Since a 50 Ω coaxial configuration is established for the whole signal flow path including the short device placed in the fixture, the theoretical inductance value of the short device can be calculated from the length and physical constants by using a transmission line formula. Its reference value is documented; however, the use of the 16196A/B/C is not subject to execution of the compensation based on the reference value. You need to select the definition method of short inductance that agrees with your measurement needs.

The chip type short devices and load devices are readily available from the working-standard set supplied for Agilent RF I-V measurement instruments. Otherwise, you can substitute appropriate devices for the short and load chips by accurately determining (or properly defining) their characteristics. Method of calibrating the load device follows.

4-6-6. Calibrating load device

To determine the values of a load device, you can utilize the same instrument that will be used to measure DUTs. Appropriate procedure for calibrating the load device is described below:

- (1) Perform open/short/load calibration at the instrument's test port. In addition, for a capacitive or an inductive load device, it is recommended that low loss capacitor calibration be performed.
- (2) Connect a direct-mounting type test fixture to the test port. It is recommended that the 16196A/B/C coaxial test fixtures be used to insure the best measurement accuracy.
- (3) Perform open and short compensation. For short measurement, the method of minimizing short impedance must be employed. (To do this, contact the terminals directly together if possible.) When the 16196A/B/C is used, consider inputting the reference value of the residual inductance of furnished short device to the instrument. (Using the reference value is contingent upon how the reference of short inductance needs to be defined for your measurement. Agilent chooses to take the historic approach to let short=0 H, but the actual user of the test fixture can choose either approach.)
- (4) Connect the load device to the test fixture, select parameters available for instrument's load calibration function (typically R-X, L-Q, L-Rs and C-D) and measure the device. Set the measurement time, test signal level and averaging so that the instrument can measure the load with a maximum accuracy (or use the specified test signal level of the device if required).

4-6-7. Electrical length compensation

In the lower frequency region, using the open/short compensation function can minimize most of test fixture residuals. In the RF region, however, this is not enough to reduce the effect of the test fixture residuals. The wavelength of RF frequencies is short and is not negligible compared to physical transmission line length of the test fixture. So, a phase shift induced error will occur as a result of the test fixture, and this error cannot be reduced by using open/short compensation. The phase shift can be compensated if the electrical length of the transmission line is known. As shown in Figure 4-16, both the electrical length compensation and open/short compensation should be performed after calibrating at the test port.

The electrical length compensation corrects phase error only and ignores propagation loss induced error. This is only effective when transmission line (test port extension) is short enough to neglect the propagation loss.

Note: Theoretical explanation for the effects of the electrical length and the compensation is given in APPENDIX D.

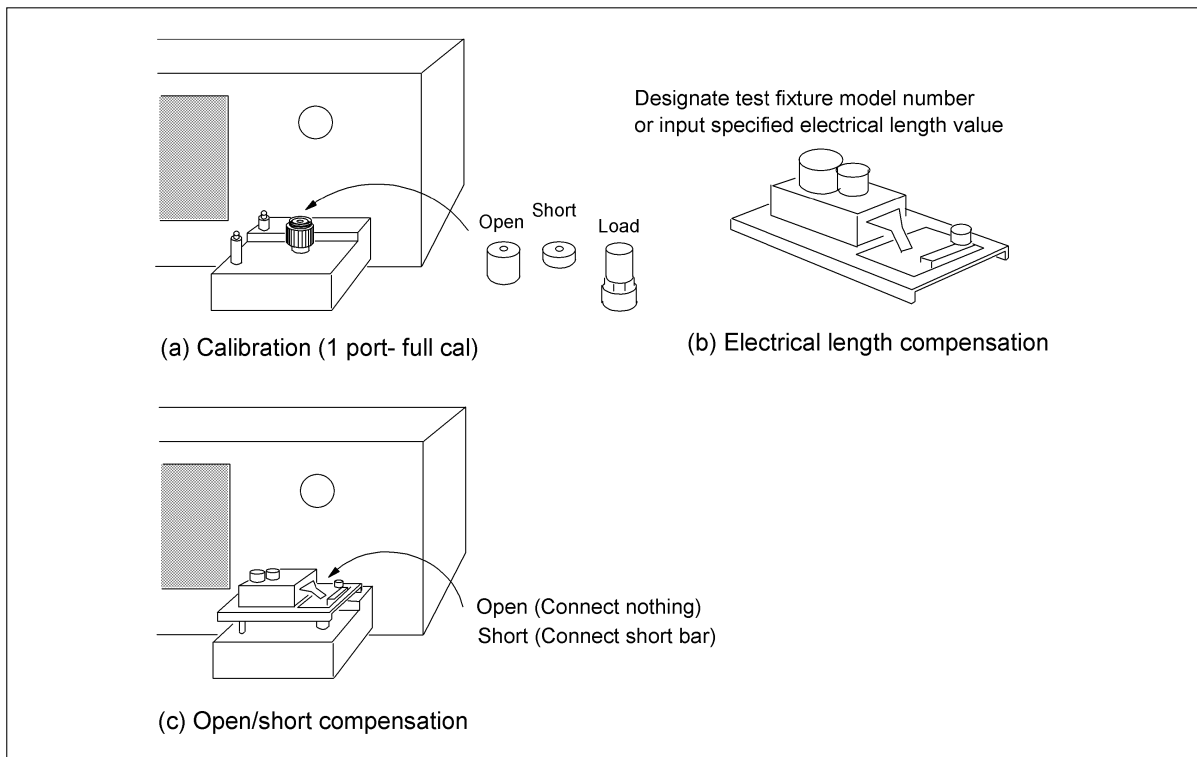


Figure 4-16. Complete calibration and compensation procedure

4-6-8. Practical compensation technique

The calibration and compensation methods suitable for measurement are different for how the test cable or fixture is connected to the test port. The following is a typical guideline for selecting appropriate calibration and compensation methods.

(1) Measurements using Agilent test fixture without test port extension

To make measurements using a test fixture connected directly to the test port, first perform calibration at the test port. After calibration is completed, connect the test fixture to the test port and, then perform electrical length compensation (for the test fixture's electrical length) and open/short compensation.

(2) Measurement using test port extension

When the measurement needs to be performed using a test port extension or a non-Agilent test fixture, it is recommended that the open/short/load calibration be performed at the measurement terminals of the test fixture. Typically, this method is applied to such a case where unknown devices are measured using a component handler. Because coaxial terminations do not match geometrically with the contact terminals of the test fixture or of the component handler, short and load devices whose values are defined or accurately known are required as substitution standards. (Open calibration requires no device.) Compensation is not required because measurements are made at the calibration plane.

4-7. Measurement correlation and repeatability

It is possible that different measurement results are obtained for the same device when the same instrument and test fixture is used. There are many possible causes of the measurement discrepancies, as well as residuals. Typical factors of the measurement discrepancies in RF impedance measurements are listed below.

- Variance in residual parameter value
- A difference in contact condition
- A difference in open/short compensation conditions
- Electromagnetic coupling with a conductor near the DUT
- Variance in environmental temperature

4-7-1. Variance in residual parameter value

Effective residual impedance and stray capacitance vary depending on the position of the DUT connected to the measurement terminals. Connecting the DUT to the tip of the terminals increase residual inductance compared to when the DUT is at the bottom. Stray capacitance also varies with the position of the DUT. See Figure 4-17.

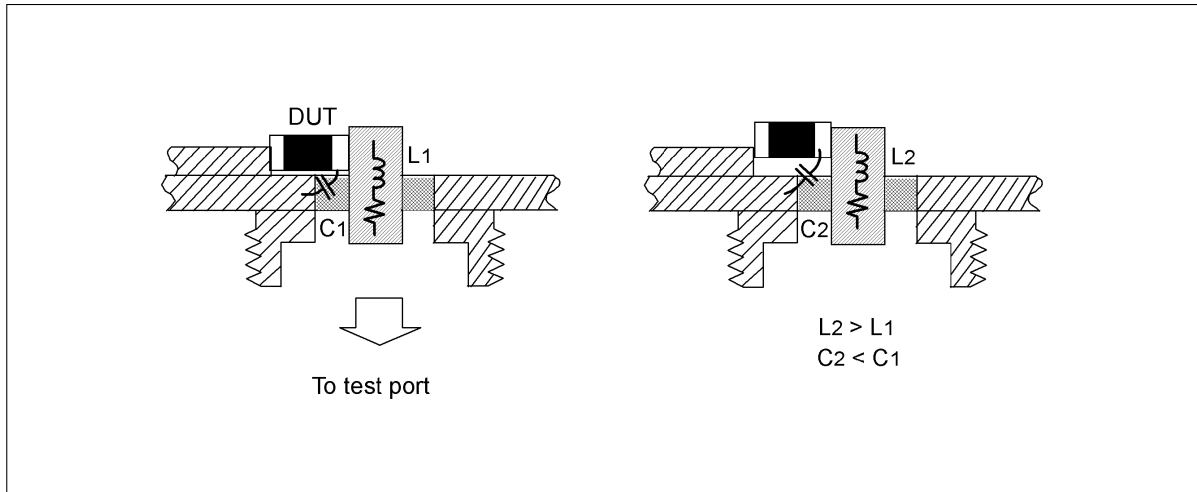


Figure 4-17. Difference in residual parameter values due to DUT positioning

4-7-2. A difference in contact condition

Change in contact condition of the device also causes measurement discrepancies. When the device is contacted straightly across the measurement terminals, the distance of current flow between the contact points are minimum, thus providing the lowest impedance measurement value. If the DUT tilts or slants, the distance of current flow increases, yielding an additional inductance between the contact points. See Figure 4-18. Residual resistance will also change depending on the contact points and produce a difference in measured D, Q or R values. The positioning error affects measurement of low value inductors and worsens repeatability of measured values.

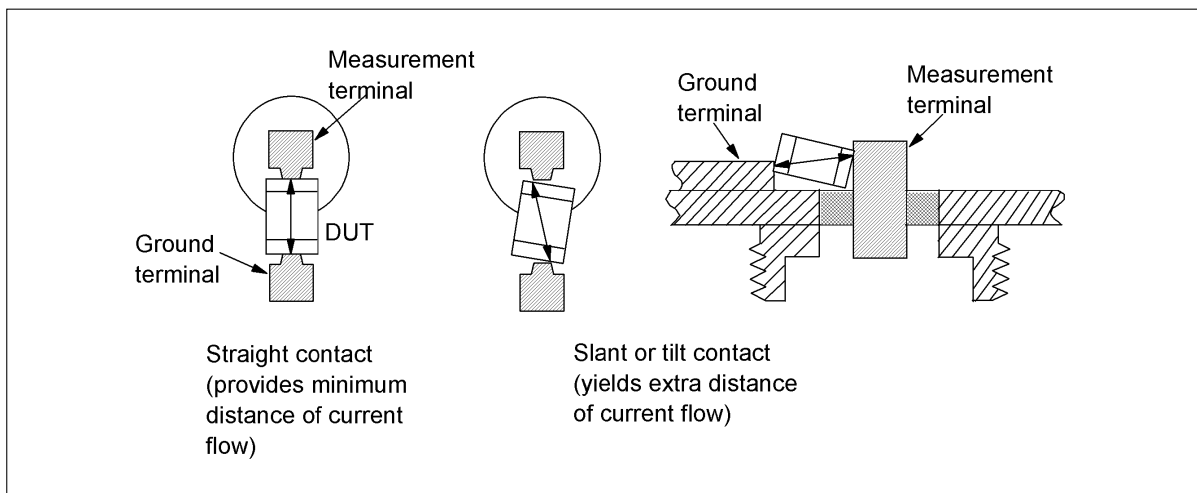


Figure 4-18. Measurement error caused by improper DUT positioning

4-7-3. A difference in open/short compensation conditions

Improper open/short measurements deteriorate accuracy of compensated measurement results. If the open/short measurement conditions are not always the same, inconsistent measurement values will result. Particularly, each short device has its inherent impedance (inductance) value and, if not defined as zero or an appropriate value, the difference of the short device used will produce resultant measurement discrepancies. Effective impedance of the short device will vary depending on how it contacts to the measurement terminals. When the bottom-electrode test fixture is used, contact points on the measurement terminals will be different from the case of the parallel-electrode test fixture, as shown in Figure 4-19. Besides, if the short device is not straight (slightly curved), the measured impedance will be different depending on which side of the device comes upside. These effects are usually small, but should be taken into considerations especially when performing a very low inductance measurement, typically below 10 nH.

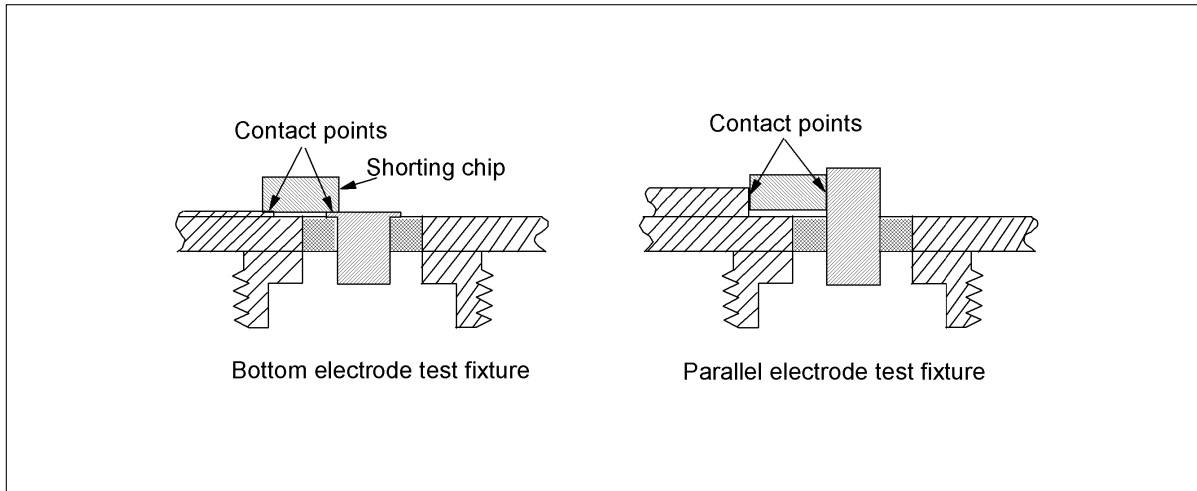


Figure 4-19. Difference in short impedance by test fixture types

4-7-4. Electromagnetic coupling with a conductor near the DUT

Electromagnetic coupling between the DUT and a metallic object near the DUT varies with mutual distance and causes variance in measured values. Leakage flux generated around inductive DUT induces an eddy current in a closely located metallic object. The eddy current suppresses the flux, decreasing the measured inductance and Q factor values. The distance of the metallic object from the DUT is a factor of the eddy current strength as shown in Figure 4-20 (a). As test fixtures contain metallic objects, this is an important cause of measurement discrepancies due to test fixture. Open-flux-path inductors usually have directivity in generated leakage flux. As a result, measured values will vary depending on the direction of the DUT. The difference in the eddy current due to the leakage flux directivity is illustrated in Figure 4-20 (b), (c) and (d). If a parasitic capacitance exists between the DUT and an external conductor, it is difficult to remove the effect on measurement because guarding technique is invalid. Thus, the DUT should be separated from the conductor with enough distance to minimize measurement errors.

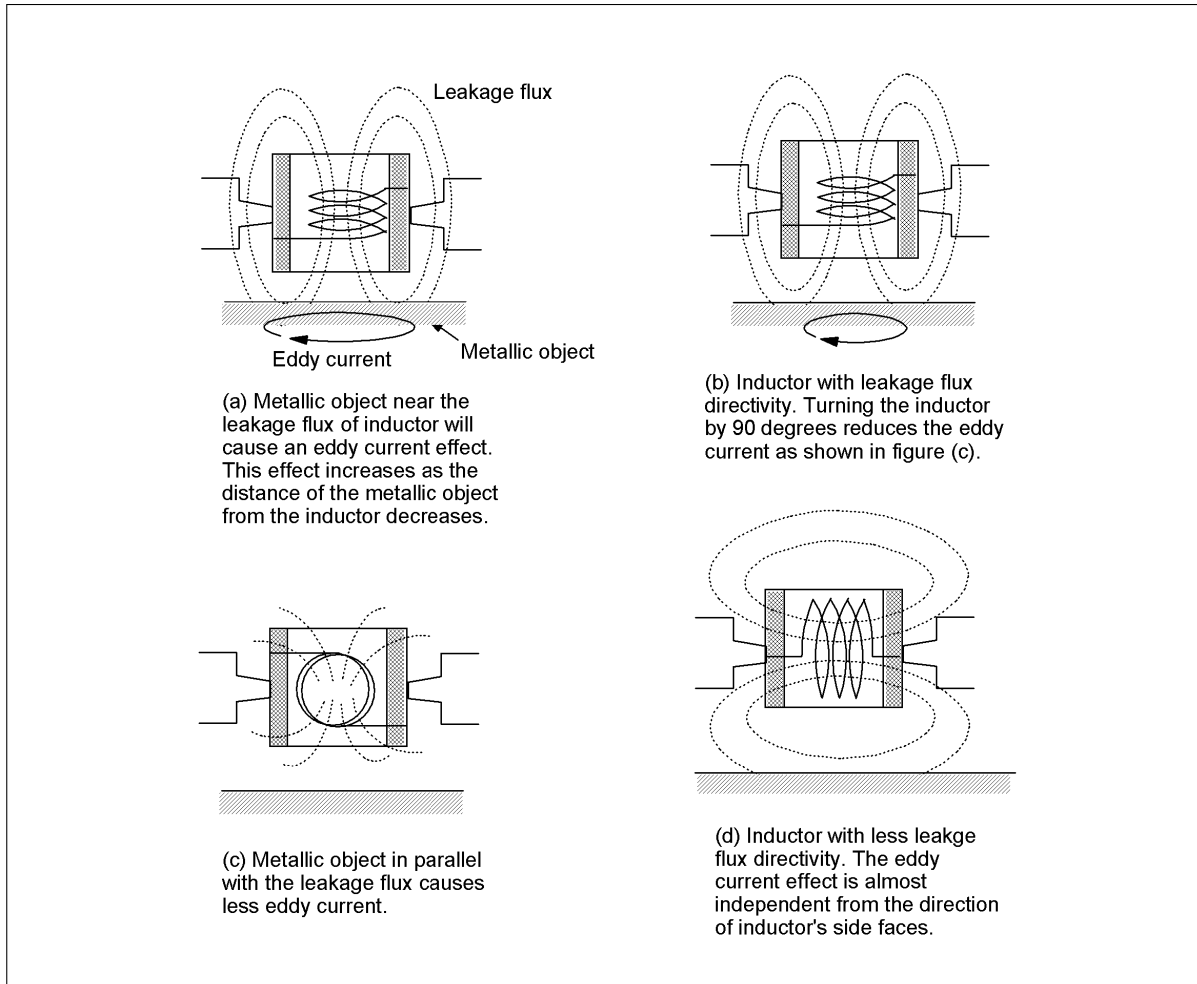


Figure 4-20. Eddy current effect and magnetic flux directivity of device

4-7-5. Variance in environmental temperature

Temperature influences on the electrical properties of materials used for the test fixtures and cables. When the test port is extended using a coaxial cable, the dielectric constant of the insulation layer (between the inner and outer conductors) of the cable as well as physical cable length will vary depending on the temperature. The effective electrical length of the cable varies with the dielectric constants, thus resulting in measurement errors.

Bending the cable will also cause its effective electrical length to change. Keep the extension cable in the same position as it was when calibration was performed.

SECTION 5

Impedance measurement applications and enhancements

Impedance measurement instruments are used for a wide variety of applications. In this section we present practical measurement examples based on real life applications. Also, special measurement techniques are covered to expand the range of impedance measurement applications.

5-1. Capacitor measurement

Capacitors are one of the primary components used in electronic circuits. The basic structure of a capacitor is a dielectric material sandwiched between two electrodes. The many available types of capacitors are classed according to their dielectric types. Figure 5-1 shows the range of generic capacitance values and Table 5-1 lists the features of the different types of capacitors according to their dielectric classification. Capacitance C, dissipation factor D, and equivalent series resistance (ESR) are the parameters generally measured.

A typical equivalent circuit for a capacitor is shown in Figure 5-2. In this circuit, the capacitance value C is the main element of the capacitor. R_s and L are the parasitics existing in the lead wires and electrodes. R_p is a parasitic that represents leakage between the two electrodes.

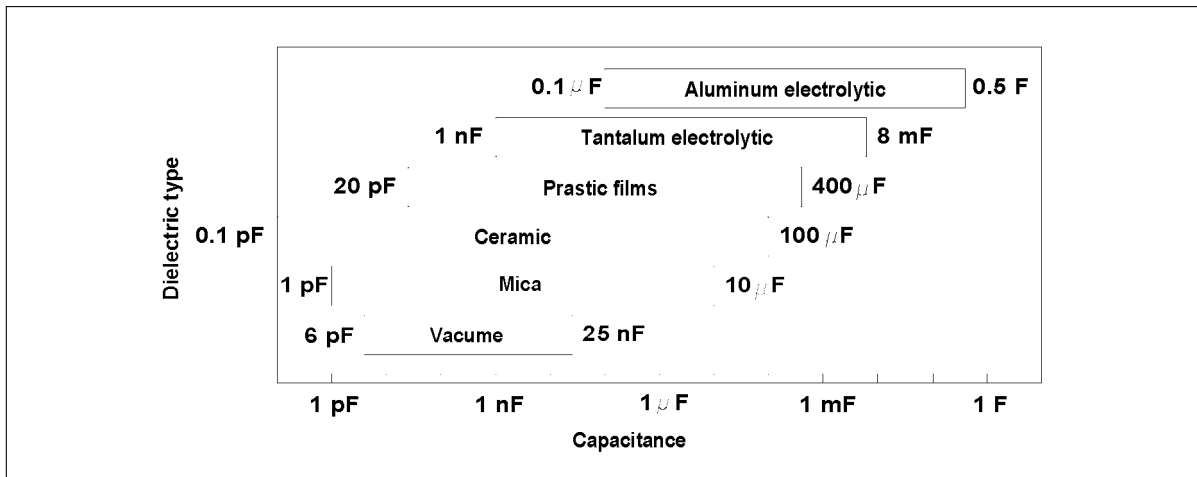


Figure 5-1. Capacitance value by dielectric type

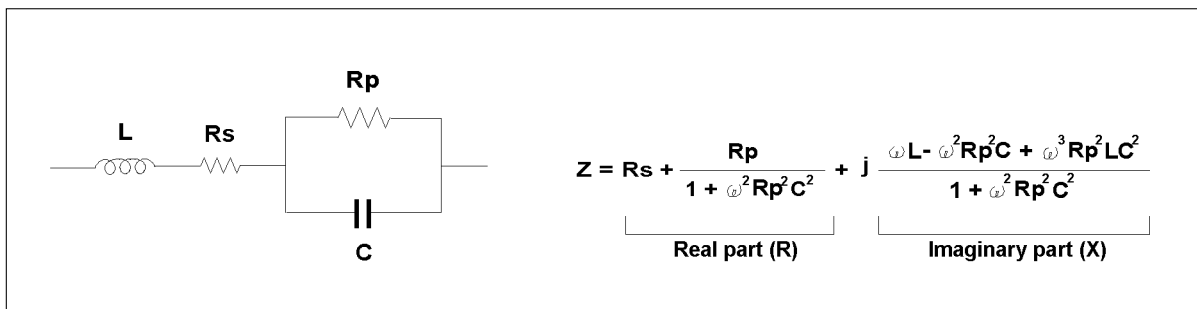


Figure 5-2. Capacitor equivalent circuit

Table 5-1. Capacitor types

Type	Application	Advantage	Disadvantage
Film	Blocking, buffering, bypass, coupling, filtering to medium frequency Tuning and timing	Wide range of capacitance and voltage values High IR, low D, good Q Stable Low TC High voltage	Medium cost
Mica	Filtering, coupling, and bypassing at high frequencies Resonant circuit, tuning High-voltage circuits Padding of larger capacitors	Low dielectric losses and good temperature, frequency, and aging characteristics Low AC loss, high frequency High IR Low cost Extensive test data, reliable	Low capacitance-to-volume ratio
Ceramic	Bypassing, coupling, and filtering to high frequency	High capacitance-to-volume ratio Chip style available Low D (low k type) Low cost	Poor temperature coefficients and time stability Large voltage-dependency and susceptible to pressure (high k type)
Tantalum electrolytic	Blocking, bypassing, coupling, and filtering in low-frequency circuits, timing, color convergence circuits, squib firing, photoflash firing	High capacitance-to-volume ratio Good temperature coefficients Extensive test data	Voltage limitation Leakage current Poor RF characteristics Medium cost Failure mode: short
Aluminum electrolytic	Blocking, bypassing, coupling, and low frequency filtering Photoflash	Highest capacitance-to-volume ratio of electrolytics Highest voltage of electrolytics Highest capacitance Lowest cost per CV unit for commercial types High ripple capability	Affected by chlorinated hydrocarbons High leakage current Requires reforming after period of storage Poor RF characteristics Poor reliability Short life

When we measure capacitors, we have to consider these parasitics. Impedance measurement instruments measure capacitance in either the series mode (Cs-D, Cs-Rs) or in the parallel mode (Cp-D, Cp-Rp). The displayed capacitance value, Cs or Cp, is not always equal to the real capacitance value C due to the presence of parasitic components. For example, when the capacitor circuit shown in Figure 5-2 is measured using the Cs-Rs mode, the displayed capacitance value Cs is expressed using the complicated equation shown in Figure 5-3. Cs is equal to C only when the value of Rp is sufficiently high ($1/R_p \ll 1$) and the reactance of L is negligible ($\omega L \ll 1/\omega C$). Generally, the effects of L are seen in the higher frequency region where L is not negligible. However, Rp can be disregarded in many cases. For high-value capacitors, the reactance of the paralleled C value is much lower than Rp. For low-value capacitors, the value of Rp itself is very high. Therefore, most capacitors can be represented as shown in Figure 5-4. Figure 5-5 (a) and (b) shows the typical impedance ($|Z| \angle \theta$) characteristics and Cs-D characteristics for ceramic capacitors. You can recognize the existence of L from the resonance point seen in the higher frequency region.

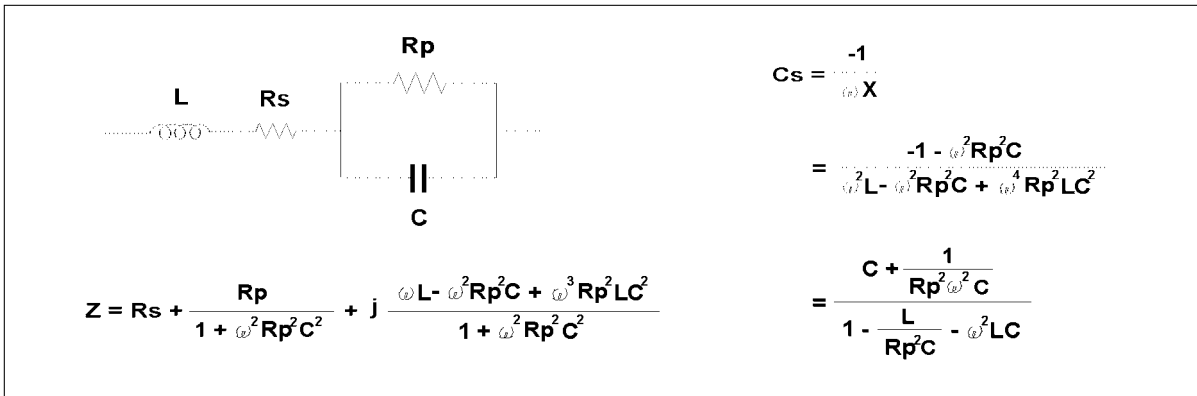


Figure 5-3. Effects of parasitics in actual capacitance measurement

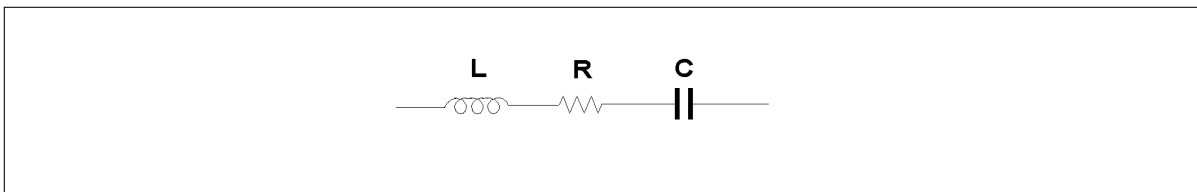


Figure 5-4. Practical capacitor equivalent circuit

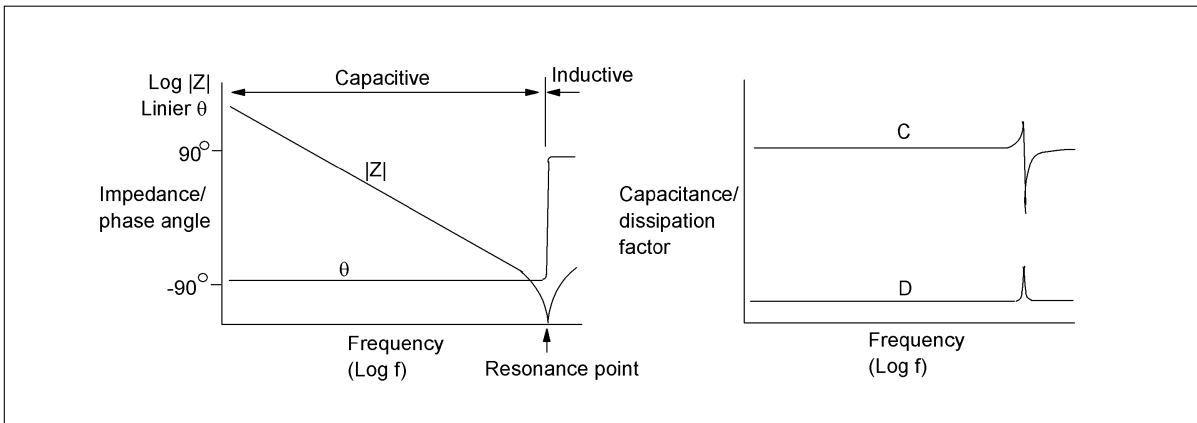


Figure 5-5. Typical capacitor frequency response

Precautions for capacitor measurement depend on the capacitance value being measured.

High-value capacitance measurement is a low impedance measurement. Therefore, contact resistance and residual impedance in the contact electrodes, test fixture, and cables must be minimized. Use a 4-terminal, 5-terminal or 4-terminal pair configuration to interconnect the DUT with the measurement instrument. When the 4-terminal or 5-terminal configurations are used, be sure that a high test signal current flows through the cable. To avoid the effects of electromagnetic field coupling, connect the cables as shown in Figure 5-6. Also, for an accurate measurement, open/short compensation should be properly performed. Especially for electrolytic capacitors which require a DC bias voltage to be applied, open/short compensation should be performed with the DC bias set to ON (0 V).

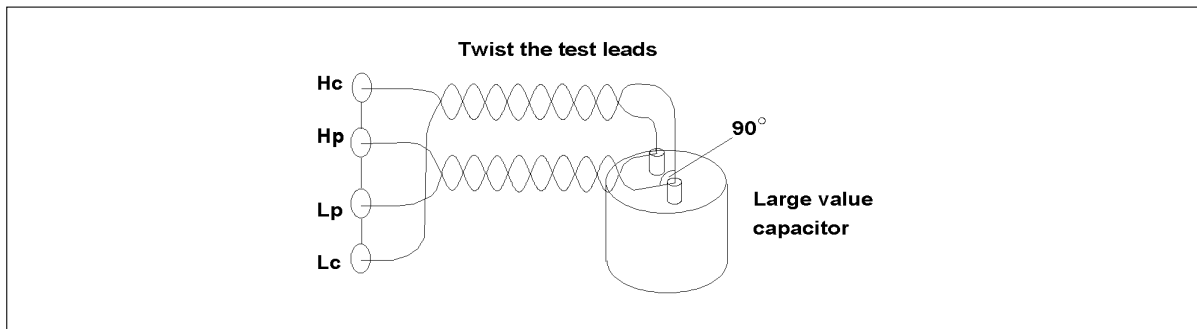


Figure 5-6. High-value capacitance measurement

Low-value capacitance measurement is a high impedance measurement. Stray capacitance between the contact electrodes is significant compared to the residual impedance. To make interconnections, use 3-terminal (shielded 2T), 5-terminal (shielded 4T), or 4-terminal pair (4TP) configurations. Proper guarding techniques and open/short compensation can minimize the effects of stray capacitance. Refer to “Eliminating stray capacitance effects” in Section 3. Figure 5-7 shows typical procedure for performing open/short compensation for Agilent 16034E/G test fixtures when measuring chip type capacitors.

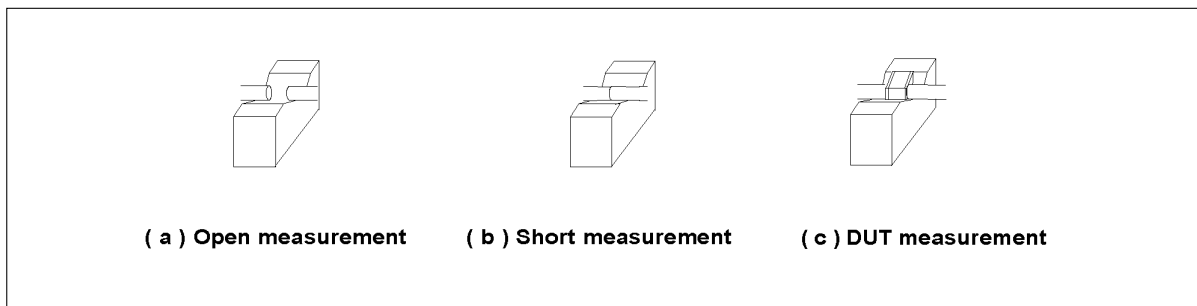


Figure 5-7. Low-value chip capacitor measurement

Other than capacitance, the dissipation factor D and the equivalent series resistance ESR are the important capacitor parameters measured. Special attention must be paid especially for low D or ESR measurements. Contact resistance and residual impedance in the test fixture and cables will affect the measurement result even when the 4-terminal configuration is used. Refer to paragraph 4-3, “Error caused by contact resistance” in Section 4.

The component dependency factors discussed in Section 1 must be taken into account especially when measuring ceramic capacitors. The capacitance of ceramic capacitors depends on frequency, test signal voltage (AC), DC bias, temperature, and time.

5-2. Inductor measurement

An inductor consists of wire wound around a core and is characterized by the core material used. Air is the simplest core material for making inductors, but for volumetric efficiency of the inductor, magnetic materials such as iron, permalloy, and ferrites are commonly used. A typical equivalent circuit for an inductor is shown in Figure 5-8 (a). In this figure, R_p represents the iron loss of the core, and R_s represents copper loss of the wire. C is the distributed capacitance between the turns of wire. For small inductors the equivalent circuit shown in Figure 5-8 (b) should be used. This is because the value of L is small and the stray capacitance between the lead wires becomes a significant factor.

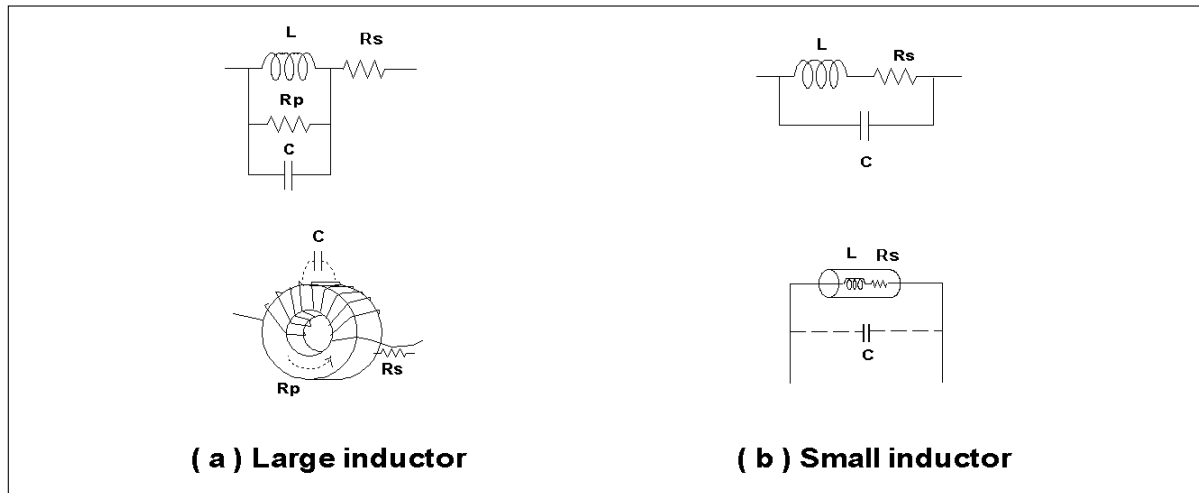


Figure 5-8. Inductor equivalent circuit

Inductance measurement sometimes gives different results when measured using different instruments. This is due to several reasons which are:

Test signal current. Cored inductors are test signal current dependent as shown in Figure 5-9 (a). Many impedance measurement instruments output a voltage driven test signal. Even when two different instruments are set to output the same voltage, their output currents are different if their source resistance is different. Refer to Figure 5-9 (b).

Test fixture used. When a metal object is located physically close to an inductor, leakage flux from the inductor will cause eddy currents to flow in the metal. The magnitudes of the resulting eddy currents are different because of the different dimensions and physical geometry of different test fixtures, as shown in Figure 5-10 (a), resulting in different measurement results. This is especially important for measuring open-flux-path inductors. Figure 5-10 (b) shows experimental measurement data for an L_s - Q measurement to see this effect. When a 1.0 mm thick brass plate, 40 mm \times 40 mm, is placed close to a small 100 μ H RF inductor, measured L_s - Q values are changed.

Q measurement accuracy. Generally, the Q measurement accuracy in impedance measurement is not high enough, especially, when measuring high Q values. Figure 5-11 shows relationship of Q accuracy and measured Q values. Because Q value is reciprocal of D ($Q=1/D$), the Q accuracy is related to the specified D measurement accuracy as shown in the figure. The Q measurement error increases with DUT's Q value and, therefore, the practically measurable Q range is limited

by allowable Q measurement error. (For example, if the allowable Q error is 10% and if the instrument's D accuracy is ±0.001, the maximum measurable Q value is 90.9. See Appendix E for Q accuracy calculation equation.) Except for resonant method, the impedance measurement instrument calculates the Q value by $Q=X/R$. Measured vector of the relatively high Q inductor is as shown in Figure 5-12. The impedance measurement error is represented by a small circle enclosing the error vector (Δ). The R value of a high Q (low loss) inductor is very small relative to the X value. Small changes in R results in large Q value changes ($Q=X/R$). Therefore, error in R measurement can cause significant error in Q, especially in high Q devices.

The following methods deliver improvement to Q measurement accuracy:

- (1) Employ the instrument with better accuracy.
- (2) Perform optimum compensation for residual resistance.
- (3) Utilize equivalent circuit analysis function and calculate Q value from the equivalent circuit parameter values obtained for the DUT. Refer to paragraph 5-14 "Equivalent circuit analysis function and its application" for details.

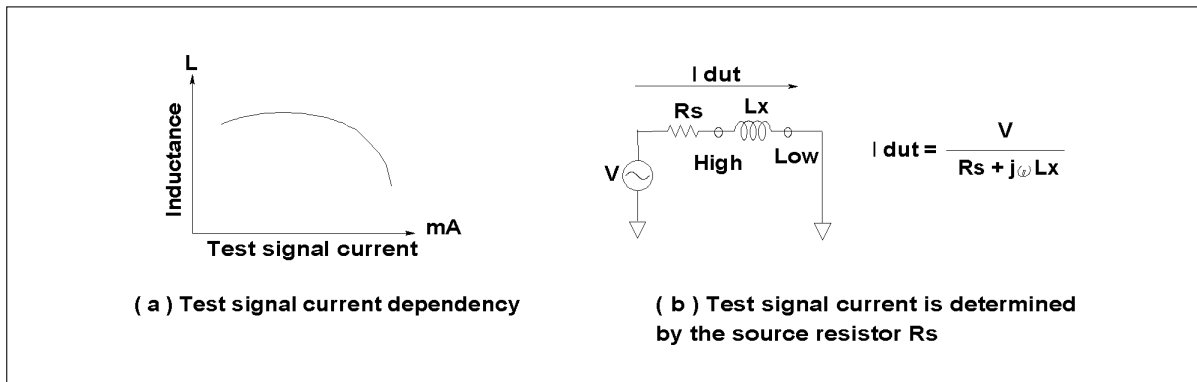


Figure 5-9. Inductor test signal current

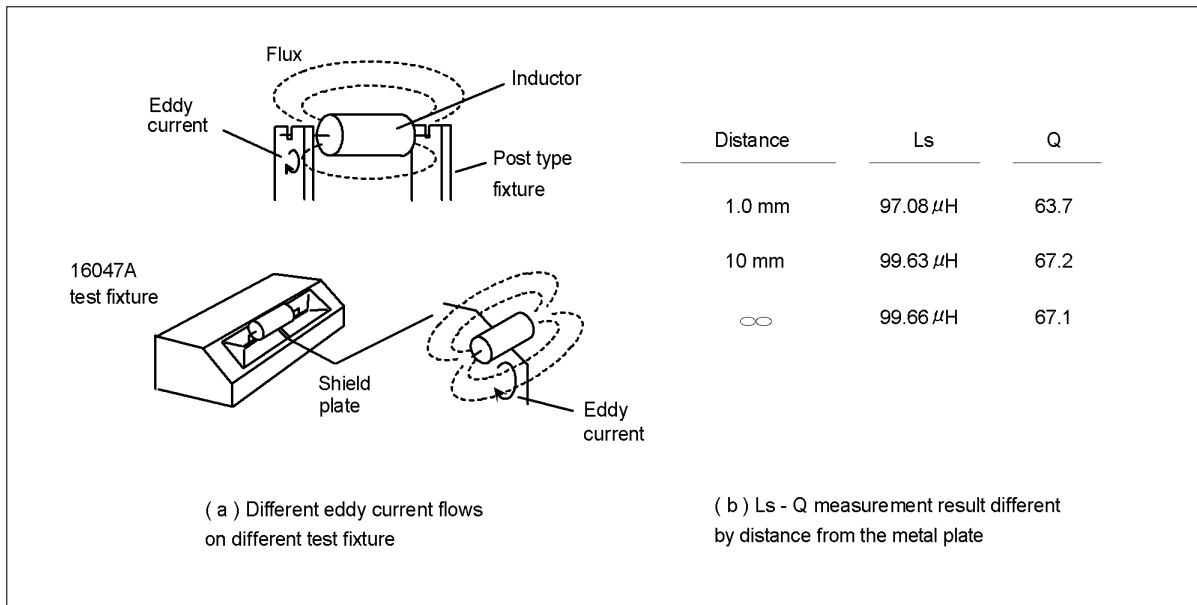


Figure 5-10. Test fixture effects

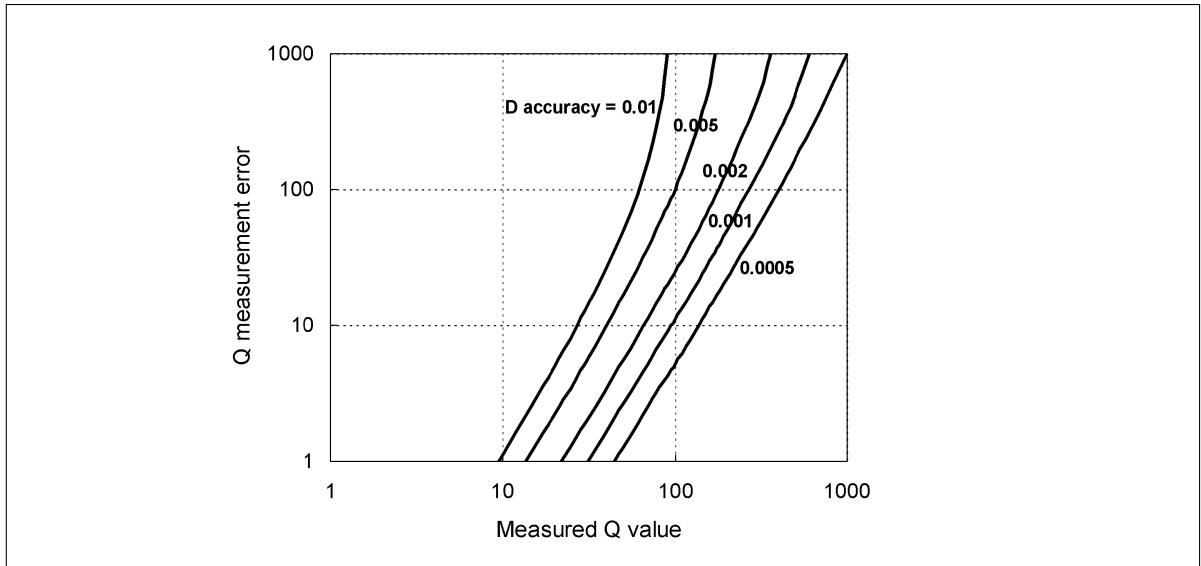


Figure 5-11. Q measurement accuracy

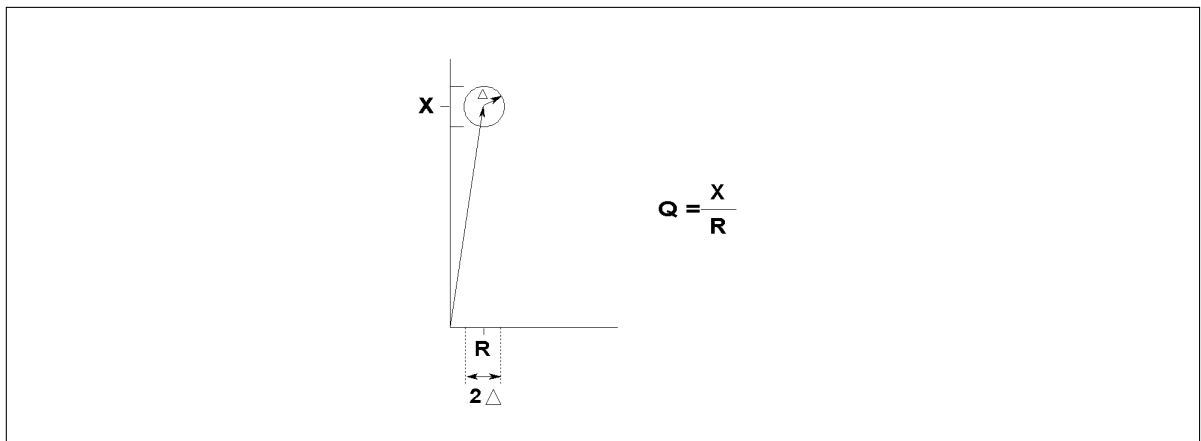


Figure 5-12. Q measurement error

Furthermore, the following phenomena may occur when a cored inductor is measured using an auto balancing bridge type instrument.

When a high level test signal is applied to an inductor, measurement may be impossible for a certain frequency range. This is because of the nonlinearity of the core material which causes harmonic distortion of the test signal current. If the test signal level is high, an excessive distortion signal will flow into the Lpot terminal of the instrument causing an unbalance or UNCAL condition (Figure 5-13 (a)). To reduce the effects caused by core material nonlinearity, decrease the test signal level, and if the measurement frequency is fixed, connect a LPF at the Lpot terminal as shown in Figure 5-13 (b).

When a test cable is used to measure low-value inductors, measurement may be impossible for certain values of inductance at higher frequencies. This is caused by resonance resulting from the test cable capacitance at the Hp and Hc terminals and the DUT's inductance. In this case, the capacitance of the cables should be changed so that the resonant frequency shifts to a much higher frequency than the highest test frequency to be used. Reduce the length of the Hc and Hp cables or use another type of cable to decrease the capacitance.

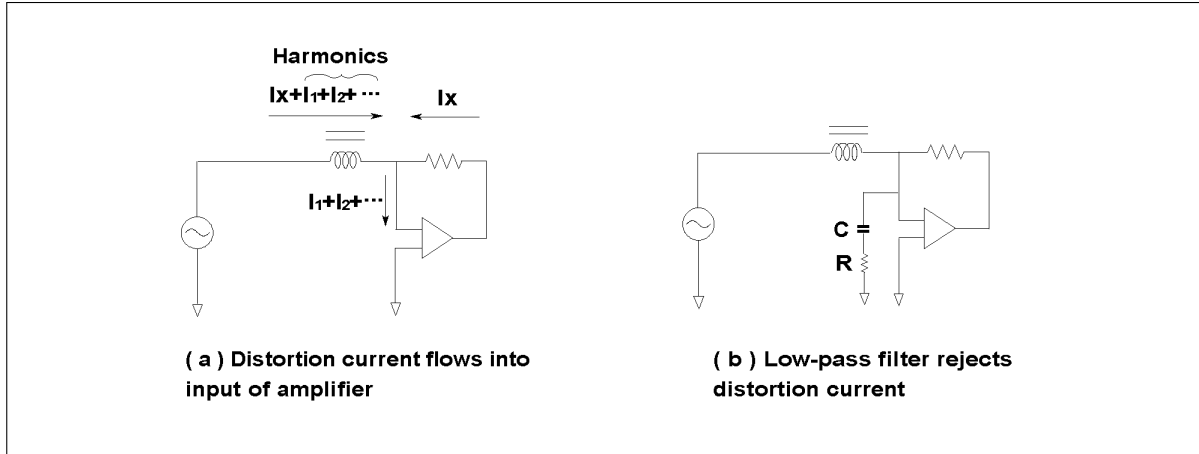


Figure 5-13. Harmonic distortion caused by inductor

5-3. Transformer measurement

A transformer is one end-product of an inductor. So, the measurement techniques are the same as for inductor measurement. Figure 5-14 shows a schematic with the key measurement parameters of a transformer. A description of how to measure these parameters follows.

Primary inductance (L1) and secondary inductance (L2) can be measured directly by connecting the instrument as shown in Figure 5-15. All other windings should be left open. Note that the inductance measurement result includes the effects of capacitance. If the equivalent circuit analysis function of the Agilent's impedance analyzer is used, the individual values for inductance, resistance, and capacitance can be obtained.

Leakage inductance Obtain leakage inductance by shorting the secondary and measuring the inductance of the primary as shown in Figure 5-16.

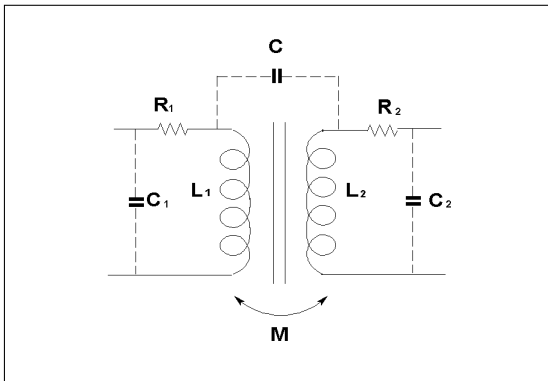


Figure 5-14. Transformer parameters

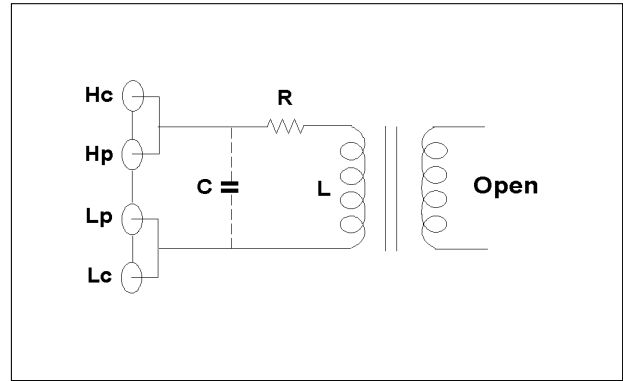


Figure 5-15. Primary inductance measurement

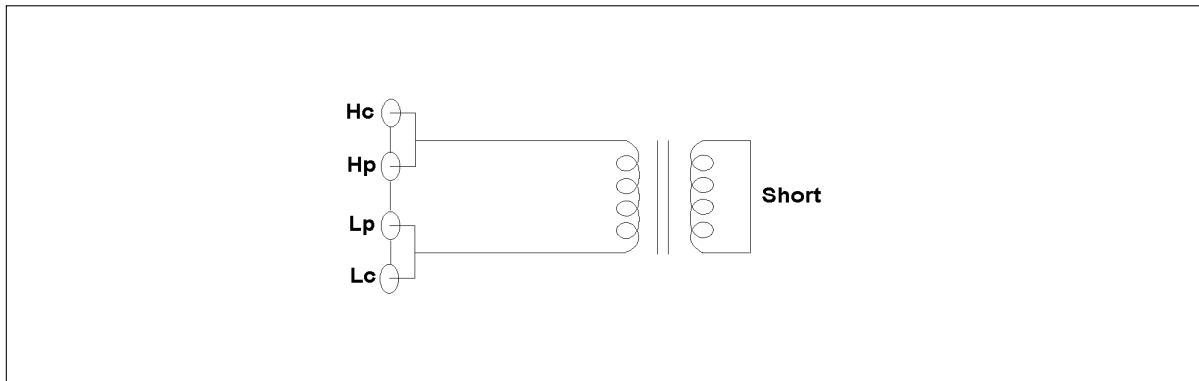


Figure 5-16. Leakage inductance measurement

Inter-winding capacitance (C) between the primary and the secondary is measured by connecting one side of each winding to the instrument as shown in Figure 5-17.

Mutual inductance (M) Obtain mutual inductance (M) by measuring the inductance in the series aiding and the series opposing configurations and then calculating the results using the equation given in Figure 5-18 (a). Mutual inductance can be measured directly if the transformer is connected as shown in Figure 5-18 (b). However, the applicable frequency range of this direct connection technique is limited by the type and the parameter values of transformer being measured. This method premises that stray capacitance effect including the distributed capacitance of windings and test lead capacitance is sufficiently small. We recommend using both techniques and cross checking the results.

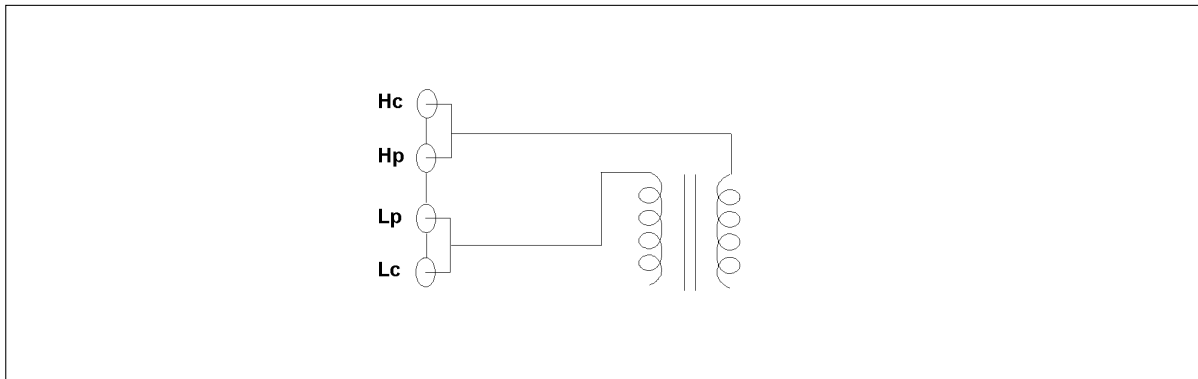


Figure 5-17. Inter-winding capacitance measurement

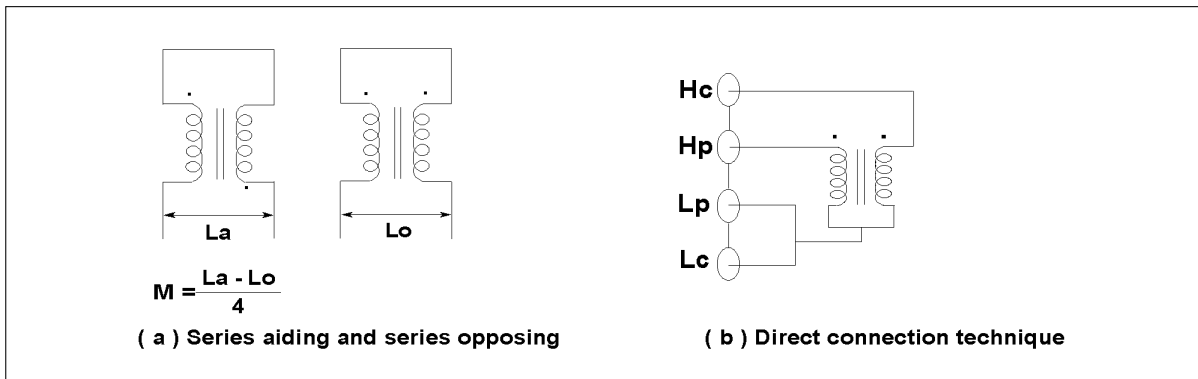


Figure 5-18. Mutual inductance measurement

Turns ratio (N) Approximate the turns ratio (N) by connecting a resistor in the secondary as shown in Figure 5-19 (a). From the impedance value measured at the primary, the approximate turns ratio can then be calculated. Direct turns ratio measurement can be made with a network analyzer or built-in transformer measurement function (option) of the 4263B LCR meter. Obtain the turns ratio from the voltage ratio measurements for the primary and the secondary, as shown in Figure 5-19 (b).

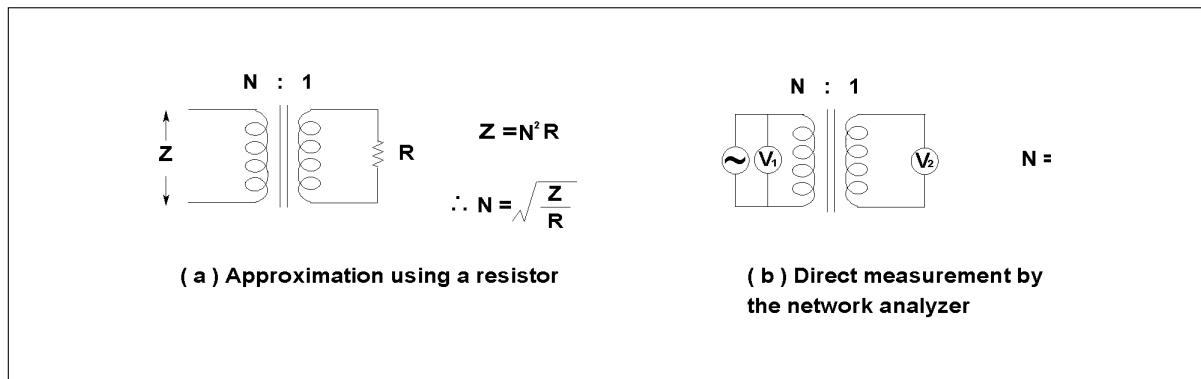


Figure 5-19. Turns ratio measurement

The 4263B's transformer measurement function enables the measurement of the N, M, L1 and the DC resistance of the primary by changing measurement circuit connections with an internal switch. Figure 5-20 shows a simplified schematic block diagram of the 4263B.

A test signal is applied to the primary and, L1 is calculated from the measured values of V1 and I1. M is calculated from V2 and I1. N is obtained from the ratio of V1 and V2.

In the DC resistance measurement, the applied voltage at the Hcur terminal is DC. DC resistance value is calculated from measured DC voltage V1 and current I1.

Using the 16060A transformer test fixture with the 4263B permits L2 and DC resistance measurement for the secondary along with all the parameters for the primary. The circuit connection diagram of the 16060A is shown in Figure 5-21.

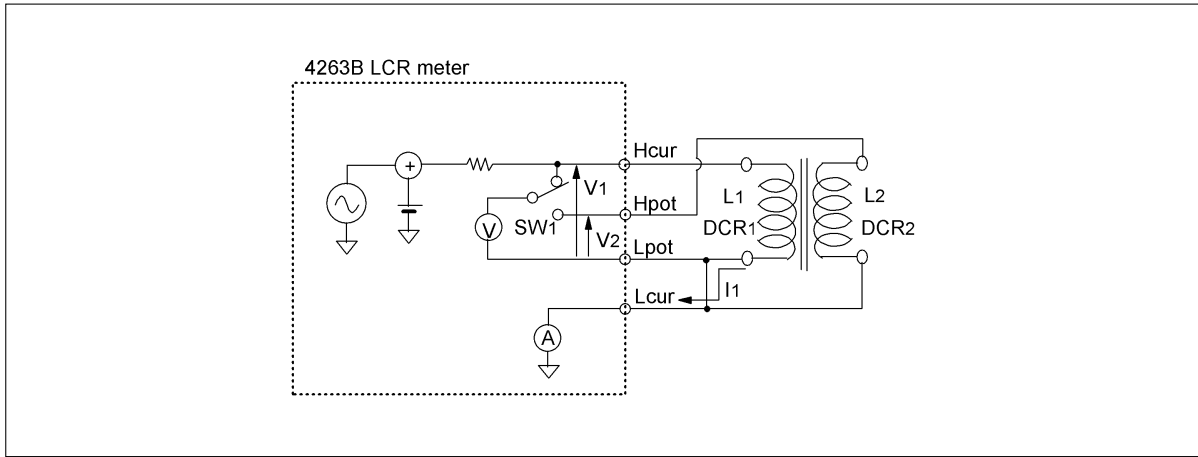


Figure 5-20. 4263B transformer measurement function schematic block diagram

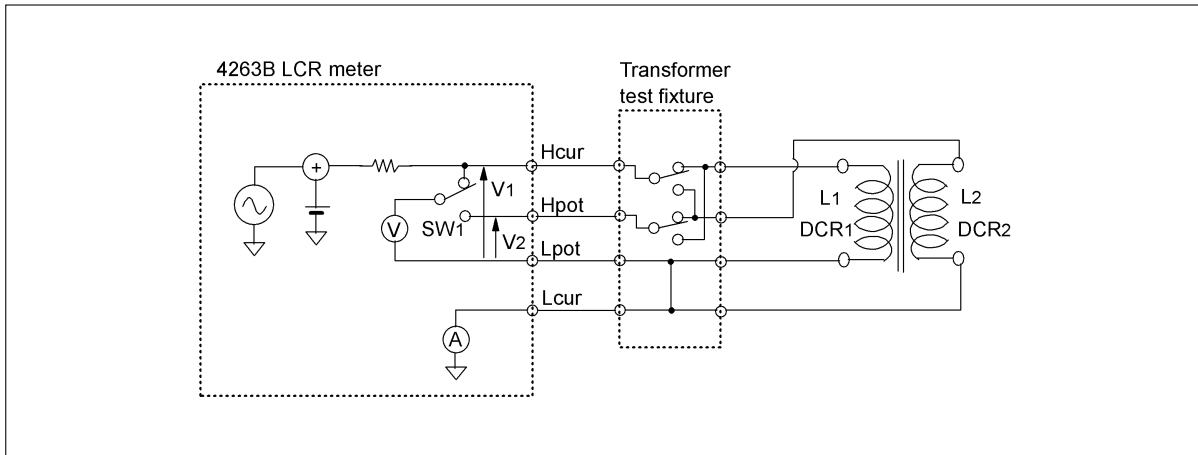


Figure 5-21. 16060A circuit connection diagram

5-4. Diode measurement

The junction capacitance of a switching diode determines its switching speed and is dependent on the reverse DC voltage applied to it. An internal bias source of the measurement instrument is used to reverse-bias the diode. The junction capacitance is measured at the same time. Figure 5-22 shows the measurement setup.

For variable capacitance diodes (varactor diode) which utilize capacitance-bias characteristics, it is important to measure capacitance accurately while applying an accurate DC bias voltage. Figure 5-23 shows an example of measuring the C-V characteristics of a varactor diode. Use a low test signal level (typically 20 mV rms) to trace precisely the relationship of the capacitance to the DC bias voltage.

The varactors for high frequency applications require Q factor or equivalent series resistance (ESR) measurement along with capacitance at a frequency above 100 MHz. The RF I-V measurement instrument is adequate for this measurement. It is possible to measure Q or ESR with the same setup as for the C-V measurement, by merely selecting the desired parameter.

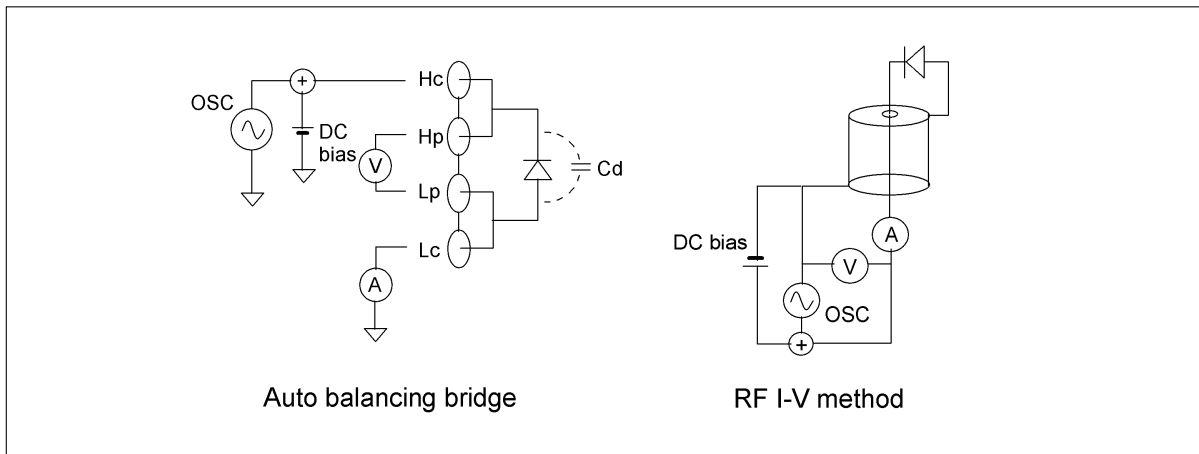


Figure 5-22. Reverse biased diode measurement setup

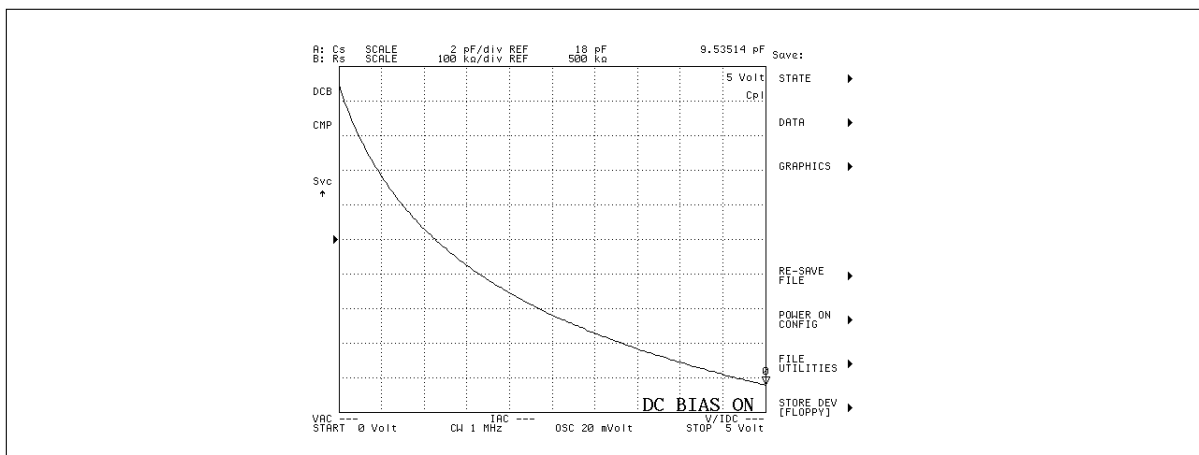


Figure 5-23. Varactor C-V characteristics

5-5. MOS FET measurement

Evaluating the capacitances between the source, drain, and gate of an MOS FET is important in design of high frequency and switching circuits. Generally, these capacitances are measured while a variable DC voltage source is connected to the drain terminal referenced to the source, and the gate held at zero DC potential (Figure 5-24). When an instrument is equipped with a guard terminal and an internal DC bias source, capacitances C_{ds} , C_{gd} , and C_{gs} can be measured individually. Figure 5-25 (a) through (c) shows the connection diagram for an instrument's High, Low, and Guard terminals. The guard is the outer conductors of BNC connectors of the UNKNOWN terminals.

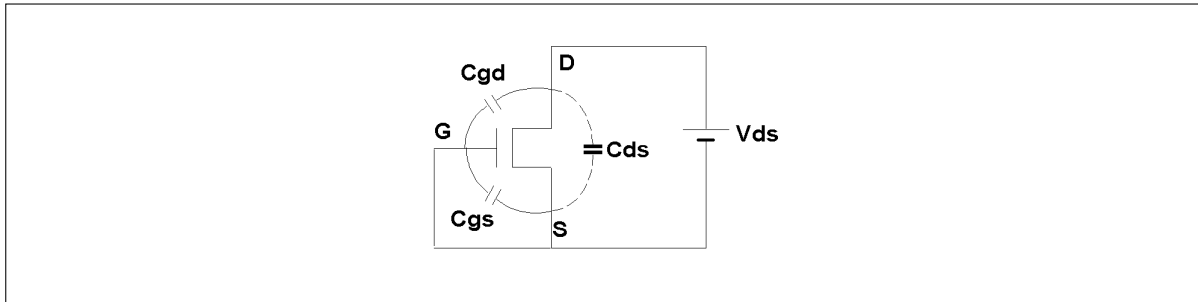


Figure 5-24. Capacitance of MOS FET

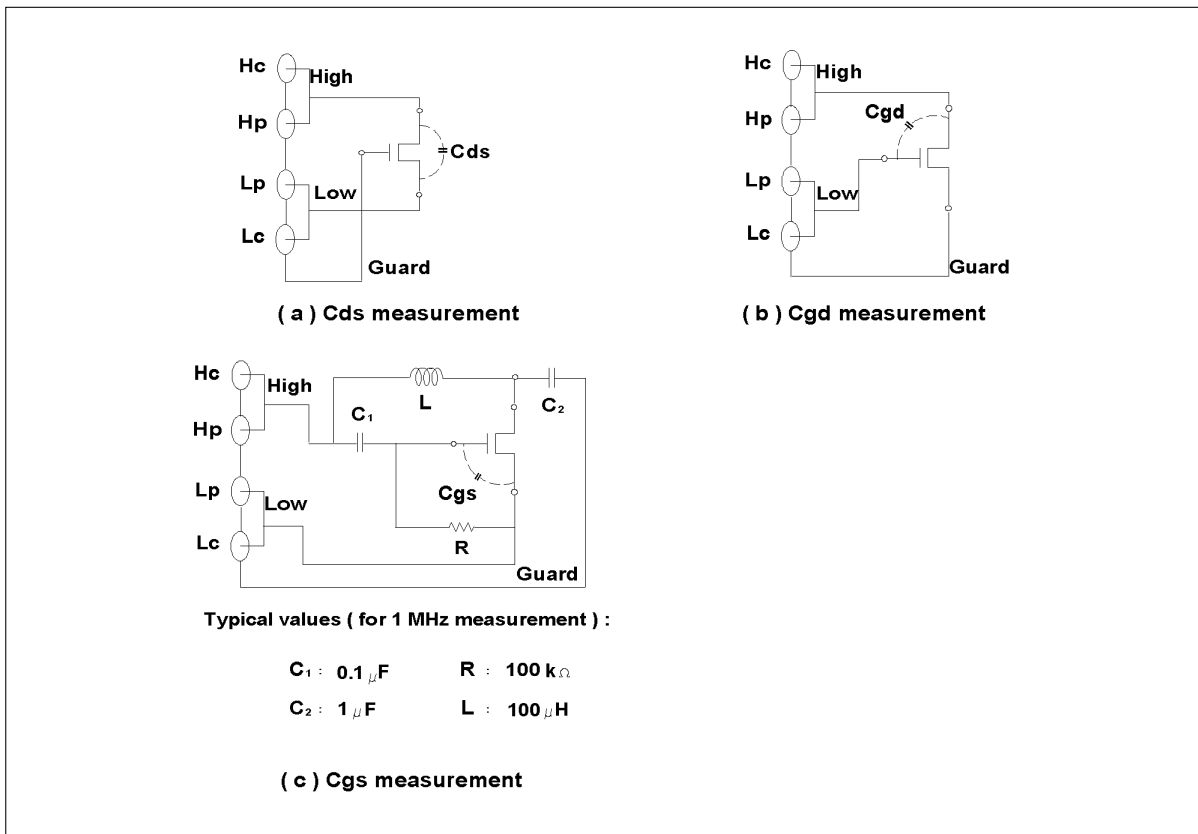


Figure 5-25. MOS capacitance measurement

5-6. Silicon wafer C-V measurement

The C-V (capacitance vs. DC bias voltage) characteristic of a MOS structure is an important measurement parameter for evaluating silicon wafers. To evaluate the capacitance that varies with applied DC bias voltage, capacitance is measured at a low AC signal level while sweeping a number of bias voltage points. Because the device usually exhibits a low capacitance (typically in the low picofarads), the instrument must be able to measure low capacitance accurately with a high resolution at a low test signal level. Precise bias voltage output is also required for accurate C-V measurement. Typical C-V measurement conditions are listed in Table 5-2. We recommend that you use an auto balancing bridge instrument to achieve the required performance.

Figure 5-26 shows a measurement setup example using the 4294A precision impedance analyzer with a prober. It is important that the Low terminal of the auto balancing bridge instrument not be connected to the substrate, since the substrate is electrically connected to the prober's noisy ground and the Low terminal is sensitive to the noise. If the wafer chuck (stage) of the prober is isolated from the ground and effectively guarded, the shielding conductor of the 4TP cable can be connected to the prober's guard terminal to minimize stray capacitance around the probes.

When a device with low resistivity is measured, applied DC voltage decreases due to DC leakage current through the device, and this may cause C-V measurement error. Using the DC bias auto level control (ALC) function helps to lessen this problem.

Table 5-2. Typical C-V measurement conditions

Frequency	10 kHz to 1 MHz (10 kHz to 100 MHz for a thin gate oxide measurement)
Capacitance range	0.0001 pF to 1000 pF
Capacitance accuracy	$\pm 0.1\%$
Test signal level	20 mVrms or 30 mVrms typical
DC bias voltage	0 V to ± 40 V
Bias voltage resolution	≤ 10 mV

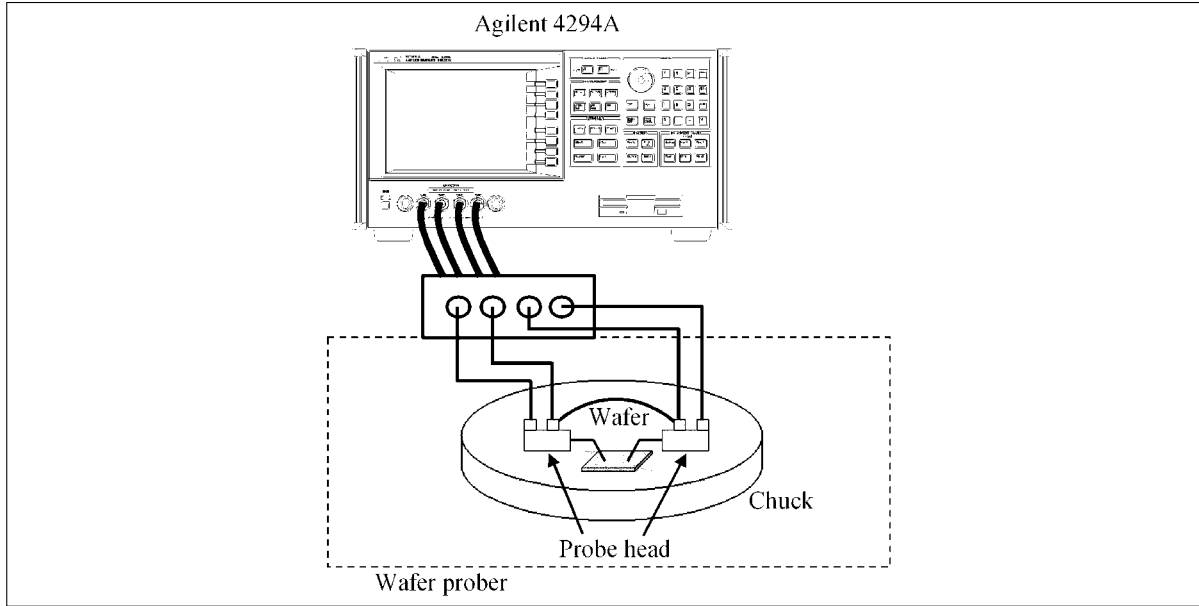


Figure 5-26. C-V measurement setup

As a result of extremely high integration of logic LSIs using MOS FETs, the thickness of the MOS FETs' gate oxide is becoming thinner (less than 2.0 nm), and such MOS FETs have been produced recently. In evaluating these kinds of MOS FETs, leakage current becomes larger by the tunneling effect because the capacitance value of a thin gate oxide has high impedance, and most of the test signal flows as leakage current. Consequently, measurement of the thin gate oxide cannot be performed accurately. To solve this problem, test frequency should be set higher (1 MHz or more) than usual to reduce the impedance value of the thin gate oxide as low as possible. It is also important to simplify the measurement configuration to reduce residuals that exist in the measurement path. If you perform high-frequency C-V measurement using the 4TP configuration, the measurement error increases due to the residual inductance of the guard cable that is connected between the probe heads. Also, the compensation does not work well because the distance between probes easily varies. To solve this problem, a simplified 2T configuration with the 42941A impedance probe, as shown in Figure 5-27, is highly recommended for accurate high-frequency C-V measurement.

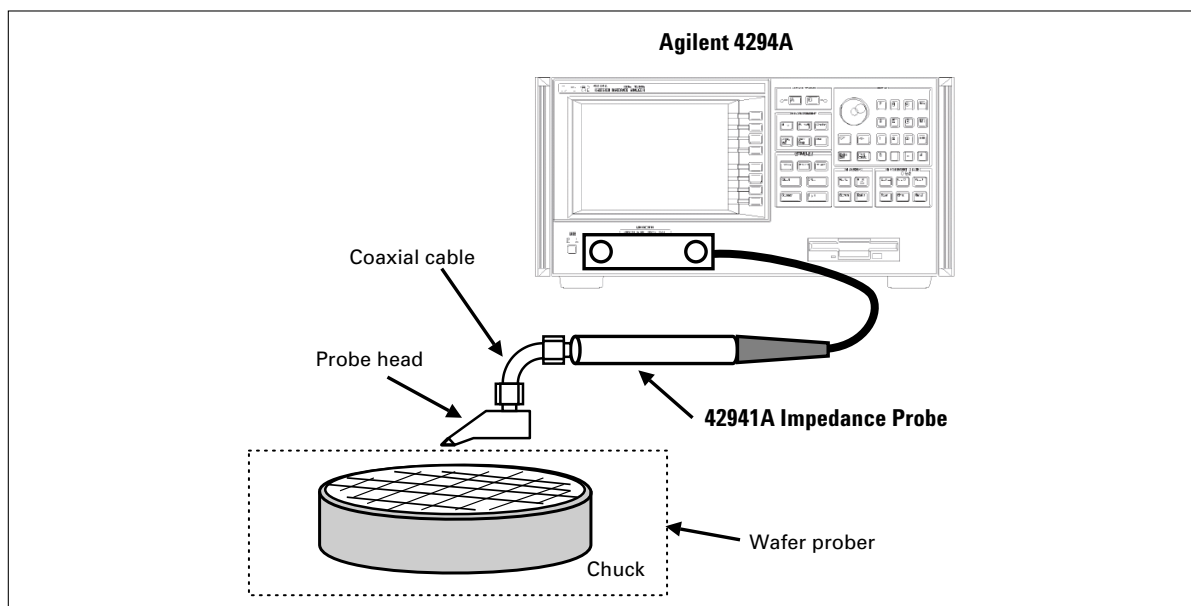


Figure 5-27. Example of high-frequency C-V measurement system configuration

5-7. High-frequency impedance measurement using the probe

As shown in Table 5-3, an RF I-V instrument can be used for a wafer's L, C, and R measurements, which are measurements in RF frequencies. Figure 5-28 shows an example measurement configuration when using the RF I-V instrument. This figure illustrates a measurement system configuration for using the E4991A RF impedance/material analyzer with a probe. Option E4991A-010, the probe station connection kit, makes it easier to establish a probing system that can perform on-wafer measurements from 1 MHz to 3 GHz. This kit contains a small test head and an extension cable.

The E4991A has calibration, compensation, and DC bias functions, and compared to a network analyzer, the E4991A provides a wider impedance measurement range and stable measurement performance (refer to section 2-6).

Table 5-3. Application examples of high-frequency impedance measurements using probe

Application	Parameters	DUT	Frequency	Measurement requirement
Spiral inductor	L, Q	RFIC for mobile phone	GHz	- Low inductance (nH range) - High Q
Transistor, Diode	C, D	CMOS FET Pin diode Transistor/diode for optical use	MHz/GHz	- Low inductance (nH range) - Low capacitance (pF range)
Disk head	C, D	GMR head, magnetic head	MHz/GHz	- Low inductance
IC package	C, L	IC package	GHz	- Low inductance (nH range) - Low capacitance (pF range)
Memory	C, D	FRAM, DRAM, SRAM	MHz, GHz	- Low capacitance (pF range)
Dielectric material	C, D	Thin film layer, PC board	MHz, GHz	- Wide impedance range - Low-loss
Chip inductor/capacitor	L, Q C, D	Chip inductor Chip capacitor	MHz, GHz	- Stable contact to small electrodes - Wide impedance range - High Q/Low D

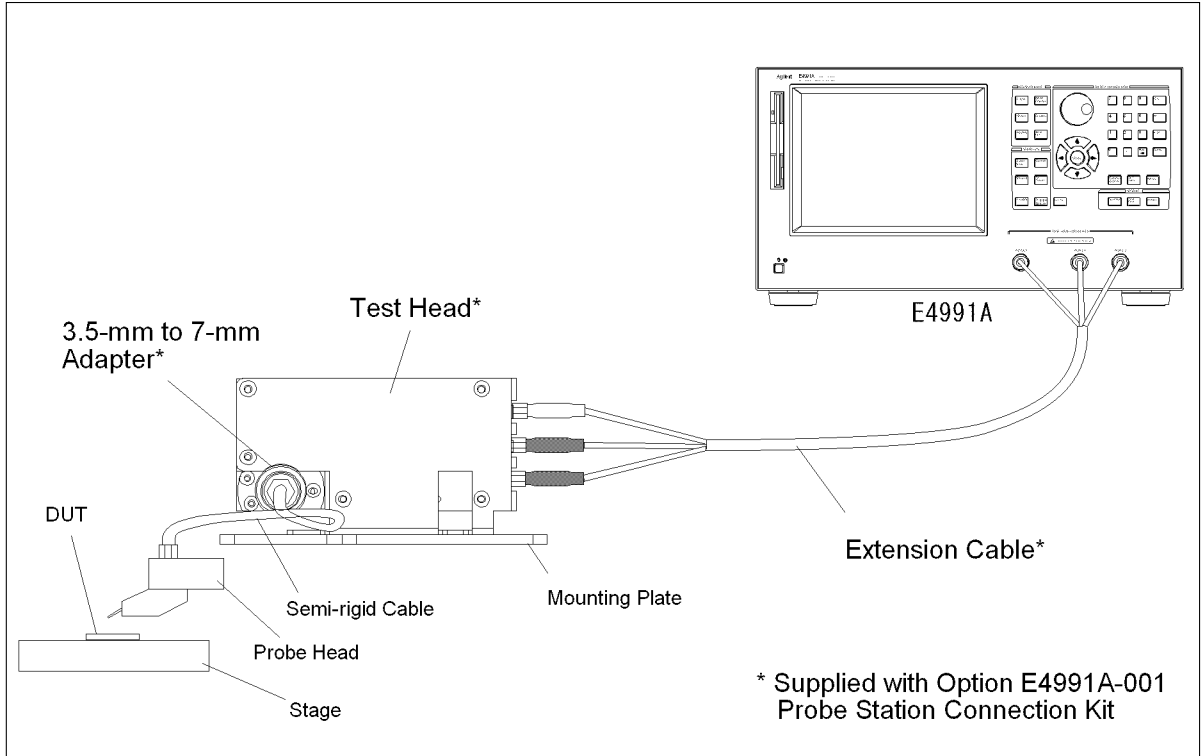


Figure. 5-28.

5-8. Resonator measurement

The resonator is the key component in an oscillator circuit. Crystal and ceramic resonators are commonly used in the kHz and MHz range. Figure 5-29 (a) and (b) show typical equivalent circuit and frequency response for a resonator. A resonator has 4 primary elements; C, L, R, and Co. C and L determine the series resonant frequency, f_r , and Co and L determine the parallel resonant frequency, f_a . Qm (Mechanical Q) is another measurement parameter used to describe the performance of resonators. An impedance analyzer or network analyzer is used to measure the resonator characteristics.

In the following methods note the impedance analyzer has an advantage in the accuracy of the measurement results.

Impedance analyzer advantages

- The impedance value at resonant frequency can be read directly. (Network analyzers generally read in units of dB.)
- Measurement accuracy for low impedance at series resonance and for high impedance at parallel resonance are better than in network analysis.
- Measurement is made by simply connecting the resonator to the test fixture, and residuals can be removed using the compensation function. (Network analyzers require a π network circuit to be connected and cannot compensate for all the residuals.)
- By using the equivalent circuit analysis function, all resonator parameters are easily known. (Network analyzers require complicated calculation or special analysis software to be used.)

Network analyzer advantages

- Faster measurement speed
- Higher measurement frequency range

Agilent's impedance analyzers are suitable for testing resonators. With its equivalent circuit analysis function, each resonator parameter can be determined individually. Also, I-Basic programming function facilitates calculation of Qm and the extraction of other parameters. Figure 5-30 shows a resonator measurement setup using an auto balancing bridge instrument for frequency range up to approximately 100 MHz. For higher frequency measurement, the same setup can be used with RF I-V measurement instrument. Take the following precautions to ensure accurate measurements.

1. It is often assumed that the series resonant frequency f_r is coincident with minimum impedance point. This is practical for an approximate measurement, but it is not the true value of f_r . The true value of f_r is given at $\theta = 0$ and is typically 1 to 2 Hz above the minimum impedance point. Search the 0° -phase angle point for f_r measurement.

2. It is important to properly set the oscillator output level; resonators are test signal dependent. The minimum impedance value and the series resonant frequency may vary depending on the applied test signal level. Decrease the test signal level while monitoring the test current (I-monitor function) until the specified test level is obtained.
3. Perform an open/short compensation. Use ALL POINT compensation mode instead of the interpolation mode because resonator measurements are narrowband. Also, pay special attention to the short compensation procedure. Improper short compensation will result in measurement error for f_r and the minimum impedance value.
4. Keep the measurement temperature constant. Resonators are temperature sensitive. Place a resonator into the test fixture with your hand and wait until the series resonant frequency becomes constant.

Figure 5-31 (a) and (b) shows the measurement result for a crystal resonator.

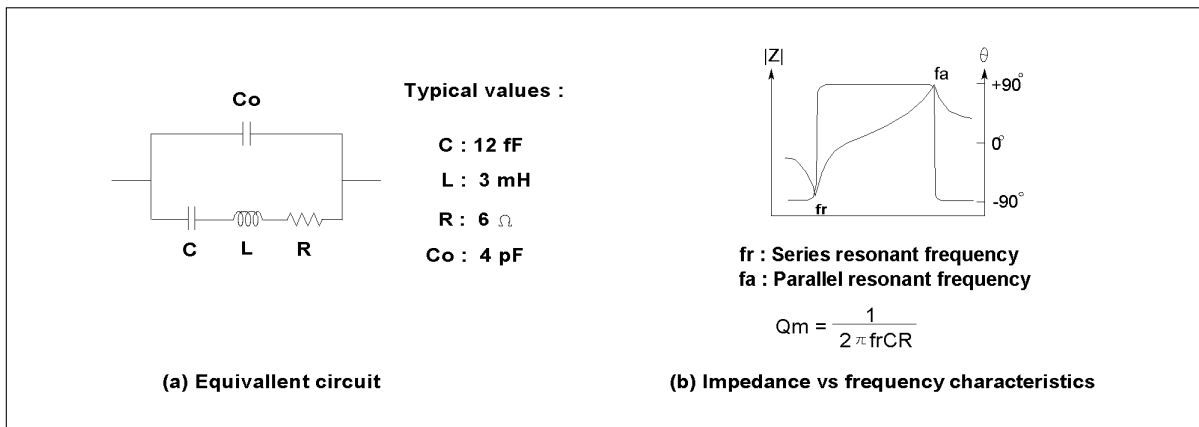


Figure 5-29. Typical resonator characteristics

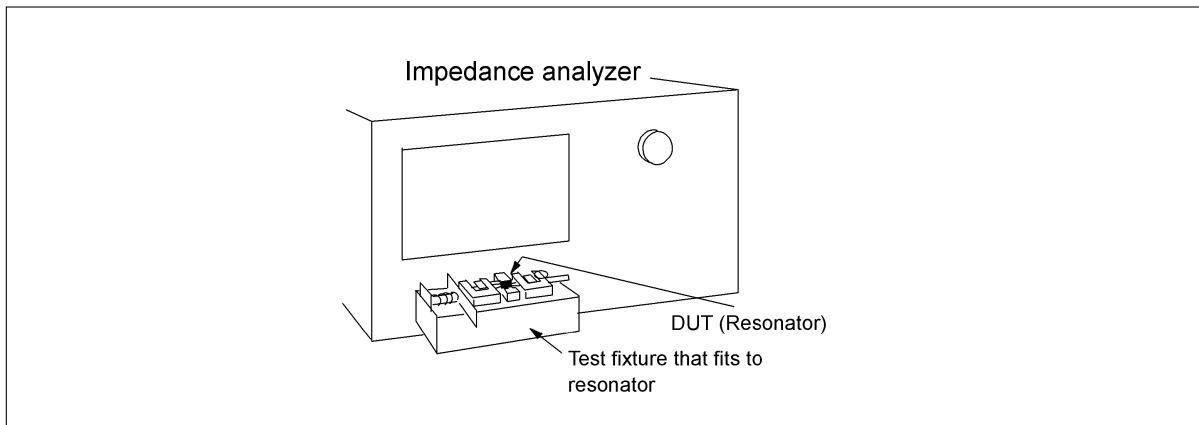


Figure 5-30. Resonator measurement setup

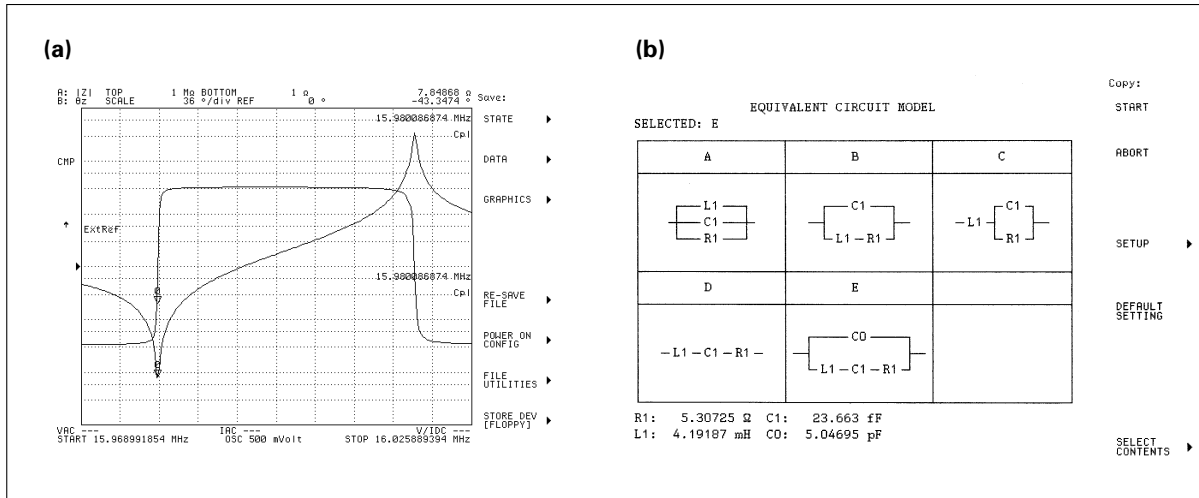


Figure 5-31. Resonator equivalent circuit mode

5-9. Cable measurements

The characteristic impedance $Z(\Omega)$, capacitance per unit length C (pF/m) and the propagation constants α (dB/m) and β (rad/m) are parameters commonly measured when evaluating cables. Figure 5-32 shows a measurement setup for coaxial cable using an auto balancing bridge type impedance analyzer and the 16047E test fixture. Note that the High terminal of the test fixture is connected to the outer conductor of the cable. This measurement setup avoids the effects of noise picked up by the outer conductor of the cable, and is important to regard when the cable length is long. The characteristic impedance and propagation constants are determined by measuring the impedance of the cable with its other end opened and shorted (open-short method), and calculating using the equations shown in Figure 5-32.

The I-BASIC programming function of the impedance analyzer facilitates the calculations required. Figure 5-33 demonstrates an example of measured characteristic impedance vs frequency.

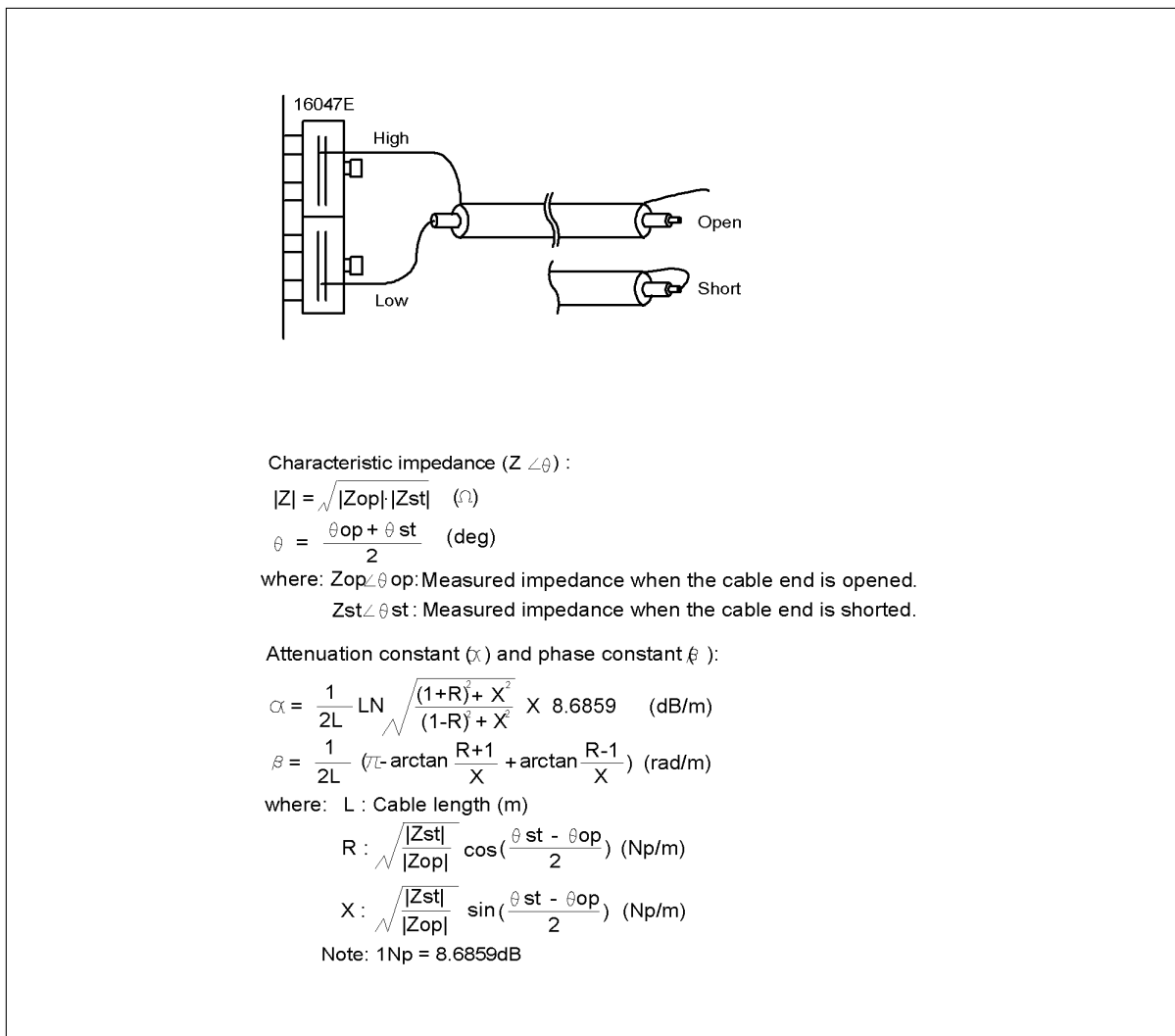


Figure 5-32. Coaxial cable measurement setup and parameter calculation

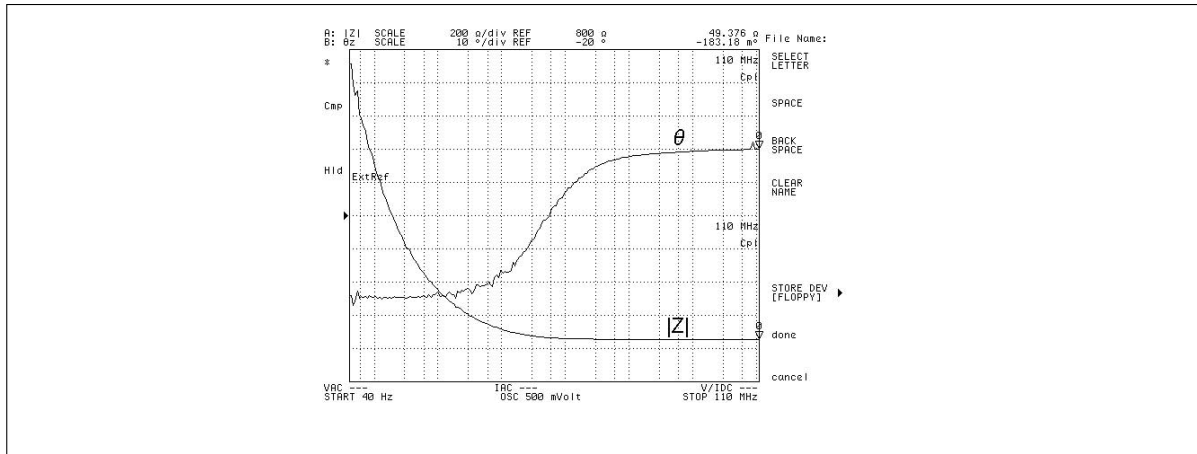


Figure 5-33. Measurement result

Balanced cable measurement

A balun transformer is required for measuring balanced cable because the instrument's UNKNOWN terminal is unbalanced. Refer to the next paragraph titled "Balanced device measurement" for details of measurement method. Figure 5-34 shows measurement setup for balanced cable. Agilent 16314A balanced/unbalanced 4-terminal converter can be used to measure balanced cables from 100 Hz to 10 MHz using an auto balancing bridge instrument. For measurement using a network analyzer, the 16315A, 16316A and 16317A are available. These converters have different characteristic impedance to allow impedance matching with DUT (cable) impedance of 50 Ω, 100 Ω and 600 Ω, respectively, as shown in Table 5-4.

Table 5-4. 16314A, 16315A, 16316A and 16317A characteristic impedance

Converter	Characteristic impedance		Applicable instrument
	Unbalanced side	Balanced side	
16314A	50 Ω	50 Ω	Auto balancing bridge instrument
16315A	50 Ω	50 Ω	Network analyzer
16316A	50 Ω	100 Ω	
16317A	50 Ω	600 Ω	

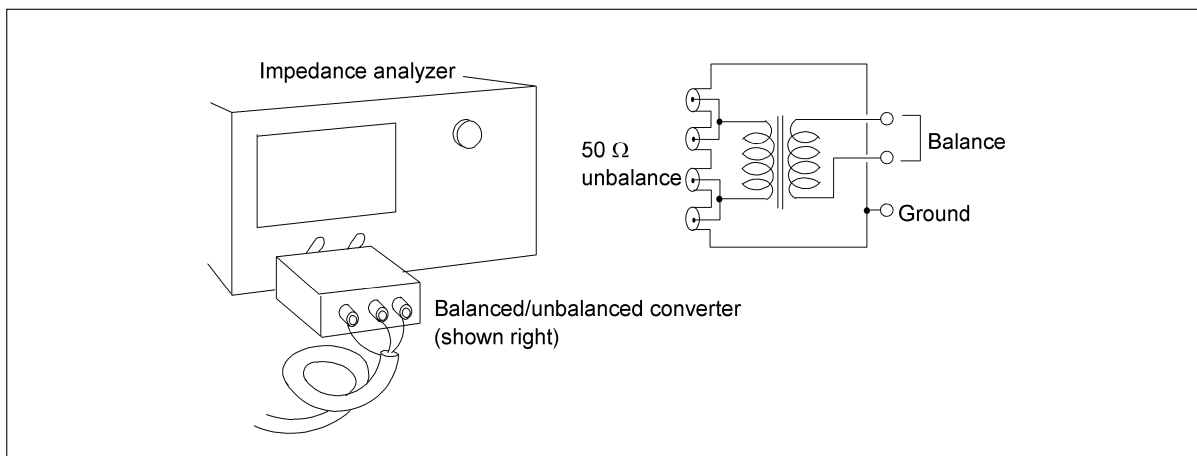


Figure 5-34. Balanced cable measurement setup

5-10. Balanced device measurement

When a balanced DUT (such as balanced cable or the balanced input impedance of a differential amplifier) is measured, it is necessary to connect a “balun” (balance-unbalance) transformer between the instrument and the DUT. Looking from the DUT side, the UNKNOWN terminals of the impedance measurement instrument are in an “unbalanced” configuration. Figure 5-35 (a) shows an example of an auto balancing bridge instrument. Its Low terminal is considered a “virtual ground” because it is held at approximately a 0 V potential. When a 1:1 balun transformer is connected as shown in Figure 5-35 (b), the instrument can measure a balanced DUT directly.

An actual balun transformer has a limited frequency range. The measurement must be made within its frequency range. In addition to Agilent’s balanced/unbalanced converters, various types of commercial balun transformers are available for various frequency ranges. To select the appropriate balun transformer, check the frequency range and the impedance of the transformer’s balanced (DUT) side. Its impedance should be close to the characteristic impedance of the DUT. The impedance of the unbalanced side should be 50 Ω or 75 Ω as appropriate for the measurement instrument.

Open/short/load compensation for the balun transformer is required when the turns ratio of the balun transformer used is not 1:1, or when an accurate measurement is needed. Open/short compensation is not adequate because the balun transformer will produce both magnitude ($|Z|$) and phase errors due to its transfer function characteristic. The terminal connectors of balanced side should be connectable for both the standard devices used for open/short/load compensation and the DUT. Figures 5-36 (a) through (d) show an example of an actual balun configuration and compensation.

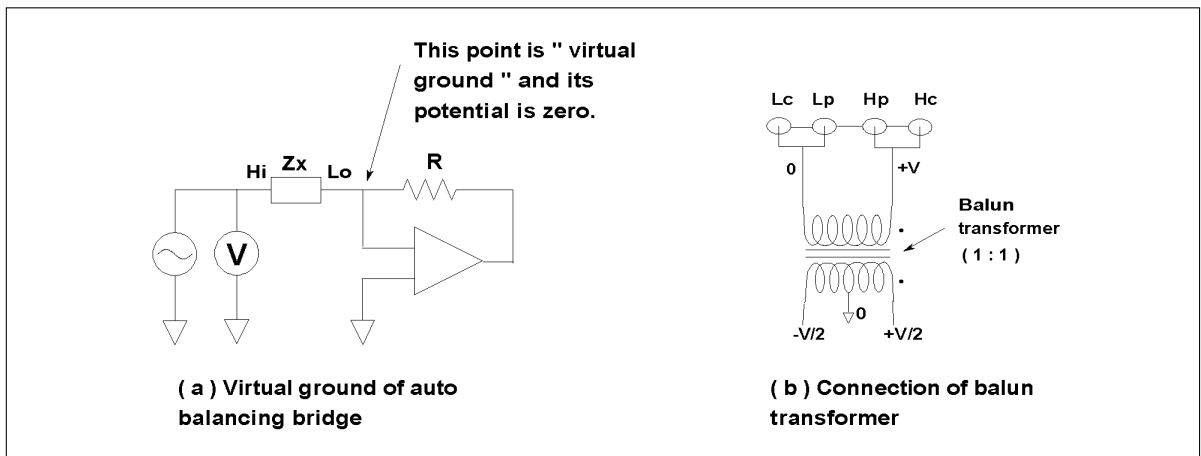


Figure 5-35. Balanced device measurement

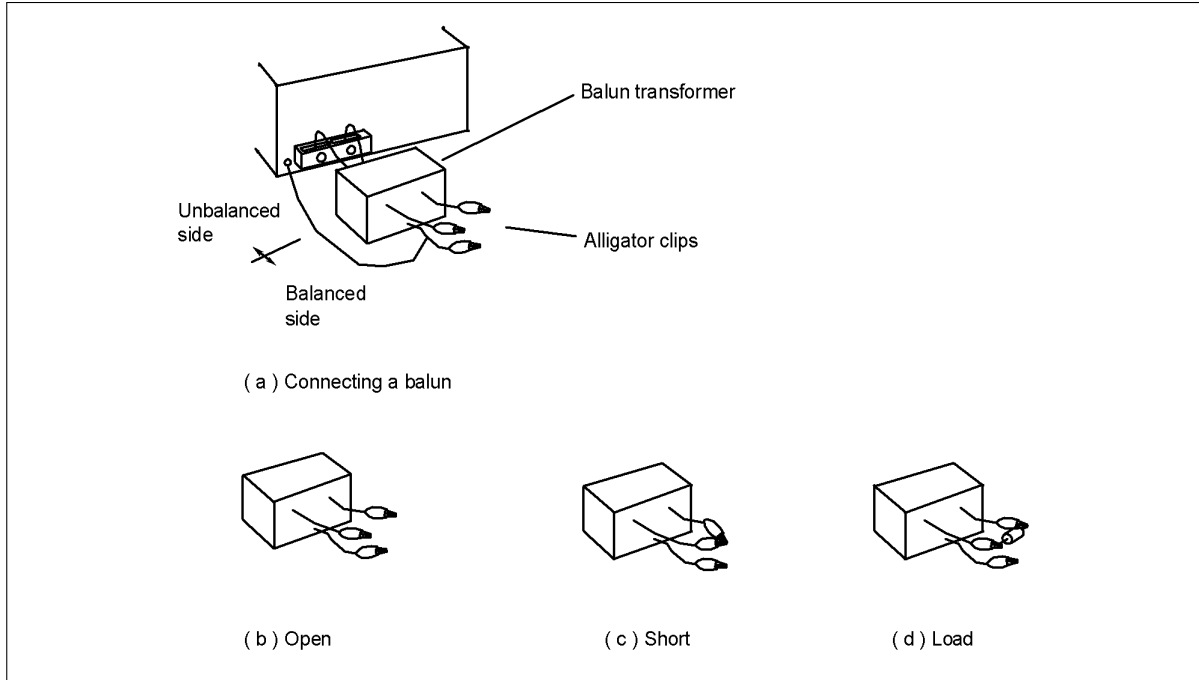


Figure 5-36. Measurement setup

5-11. Battery measurement

The internal resistance of a battery is generally measured using a 1 KHz AC signal. When a battery is connected directly to the auto balancing bridge type impedance measurement instrument, the instrument becomes the DC load, typically 100 Ω for the battery. Figure 5-37 shows the recommended setup for this measurement. C1 and C2 block DC current flowing into the instrument. The value of C1 should be calculated using the minimum measurement frequency. For example, when the measurement is made at 1 kHz and above, C1 should be larger than 32 μF . The voltage rating of C1 and C2 must be higher than the output voltage of the battery.

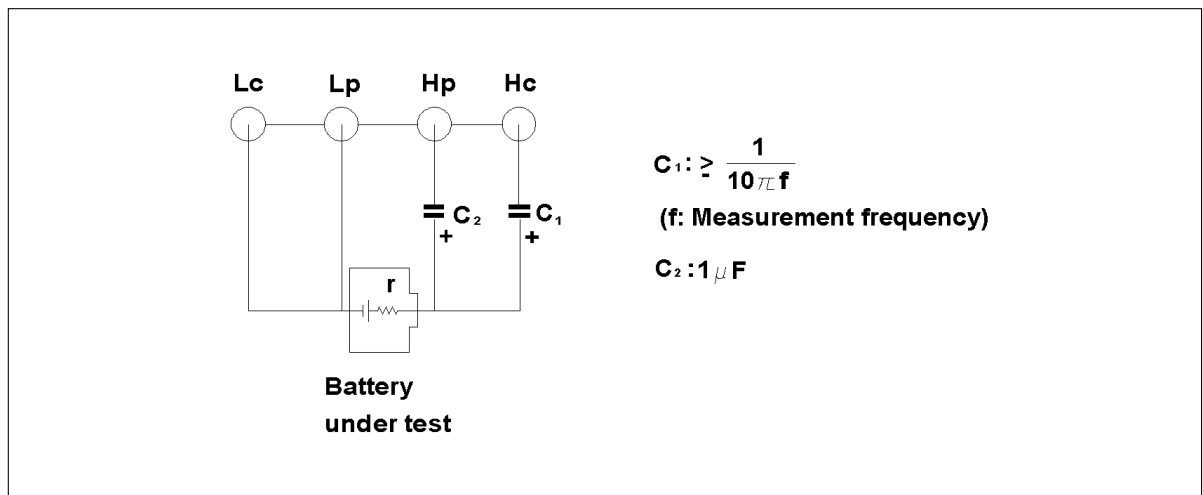


Figure 5-37. Battery measurement setup

5-12. Test signal voltage enhancement

When measuring the impedance of test signal level dependent devices, such as liquid crystals, inductors and high value ceramic capacitors, it is necessary to vary the test signal voltage. Many of the auto balancing bridge instruments employ a test signal source whose output is variable typically from 5 mV to 1V rms. Particularly, the 4284A precision LCR meter with the option 4284A-001 can output a test signal voltage of up to 20 V rms and is the most suitable for this application. In some cases, measurement needs exist for evaluating impedance characteristics at large test signal voltages of interest. There are such cases that higher test voltages than the maximum oscillator output of the instrument are required. For auto balancing bridge instruments, output voltage enhancement is possible if the test signal is amplified as shown in Figure 5-38. A voltage divider is also required so that the input voltage of the Hp terminal is the same as the output voltage of the Hc terminal. The DUT's impedance is a concern. Because the current flowing through the DUT is also amplified and flows directly into the Rr circuit, it should not exceed the maximum allowable input current of the Lc terminal. Typically, this is 10 mA. For example, when a 10 V rms signal is applied to the DUT, the minimum measurable impedance is $10 \text{ V}/10 \text{ mA} = 1 \text{ k}\Omega$. Also, it should be noted that measured impedance is $1/A$ (gain of amplifier) of an actual DUT's impedance. For example, when a 10 pF capacitor is measured using $\times 10$ amplifier, displayed value will be 100 pF.

Note: For RF I-V instrument, it is impossible to amplify the test signal because at the test port the signal source output is not separate from the voltmeter and current meter inputs.

Figure 5-39 shows a measurement setup example to boost the test signal voltage by factor of 10 ($A=10$). The amplifier used in this application should have constant gain in the measurement frequency range and output impedance less than 100Ω . R3 and C2 in Figure 5-39 are used to compensate for measured impedance value and its frequency response, respectively. To increase measurement accuracy R3 and C2 need adjustment. This can be accomplished by comparing the measured values with known values of a reference device. For better accuracy, perform the open/short/load compensation at a test signal level below 1 V rms (not to cause an excessive current to flow in short condition.) The required circuit constants of the divider are different depending on the input impedance of the Hp terminal of the instrument.

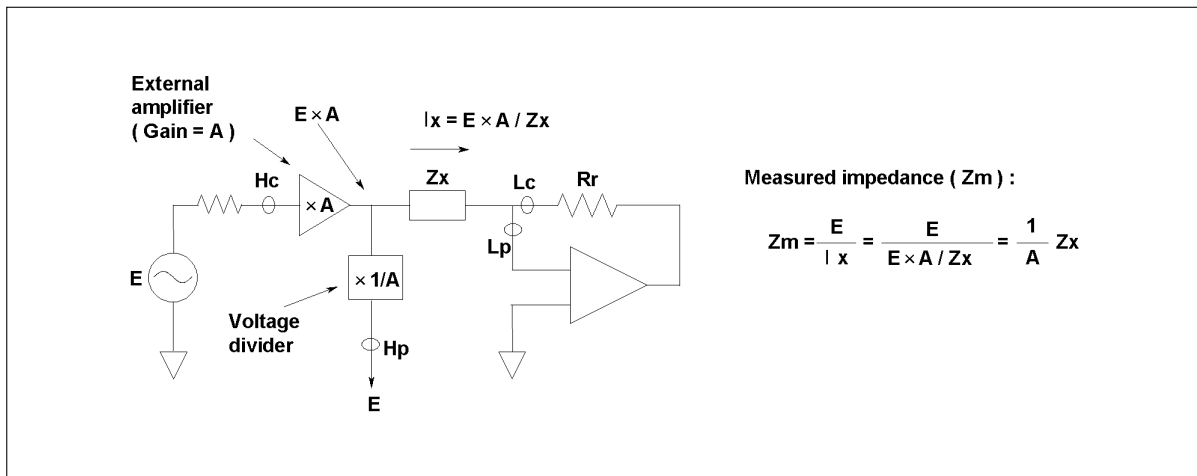


Figure 5-38. Schematic diagram of test signal voltage enhancement circuit

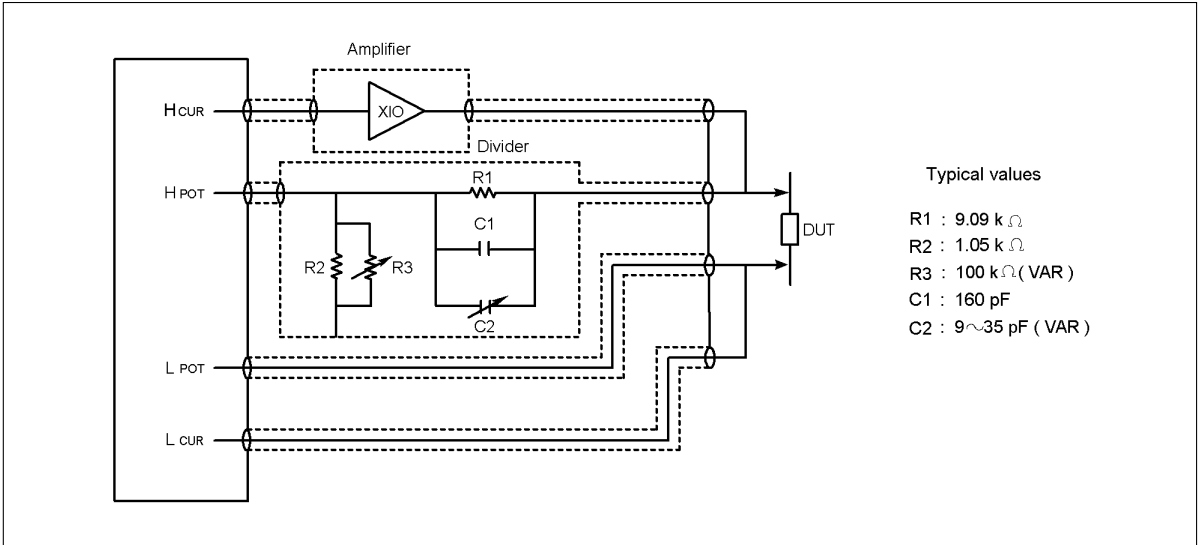


Figure 5-39. Connection diagram of test signal voltage enhancement circuit

5-13. DC bias voltage enhancement

DC biased impedance measurement is popularly used to evaluate the characteristics of the device under the conditions where the device actually operates in circuits. The internal DC bias function of the impedance measurement instruments is normally designed to apply a bias voltage to capacitor DUTs. It is suited to DC biased capacitor measurements.

Maximum applicable bias voltage is different for instruments. The internal bias source can typically output a variable bias voltage of up to ± 40 V through the Hc terminal. An external DC voltage source is required to apply a DC bias voltage that must exceed the limits of the internal DC bias function.

Some instruments have a DC bias input terminal for connecting an external DC voltage source. Use an external bias fixture or adapter for other instruments with no internal DC bias and for DC bias requirements that exceed the maximum voltage of the bias input terminal. Table 5-5 lists the available bias fixture and adapters.

Table 5-5. External bias fixture and adapters

Model number	Product type	Applicable instrument	Maximum bias voltage and current	Usable frequency range	Applicable DUT type*
16065A	Bias fixture	4-terminal pair	± 200 V, 2 mA	50 Hz to 2 MHz	Leaded
16065C	Bias adapter	4-terminal pair	± 40 V, 20 mA	50 Hz to 2 MHz	Leaded and SMD
16200B	Bias adapter	RF I-V 4294A+ 42942A	± 40 V, 5 A	1 MHz to 1 GHz	Leaded and SMD

Note: Applicable DUT types for the 16065C and 16200A depend on the test fixture connected.

Use the 16065A external voltage bias fixture, which has a built-in protection circuit, for leaded devices and high voltage DC bias of up to ± 200 V. Figure 5-40 shows the setup for a + 200 V DC biased measurement. Since the 16065A is equipped with a bias monitor output, a digital voltmeter is used to monitor the DC bias voltage actually applied to the DUT. The 16065C external voltage bias adapter is designed to apply a bias voltage of up to ± 40 V from an external voltage source. This adapter can be connected between any 4-terminal pair test fixture and instrument's UNKNOWN terminals, thus allowing the use of an appropriate test fixture that accommodates the DUT. The 16200B external DC bias adapter operates specifically with the RF I-V measurement instruments and the 4294A with the 42942A. This adapter resolves both voltage bias and current bias needs. When used for capacitor measurements, it allows a bias voltage of up to 40 V DC across the DUT by using an external DC voltage source.

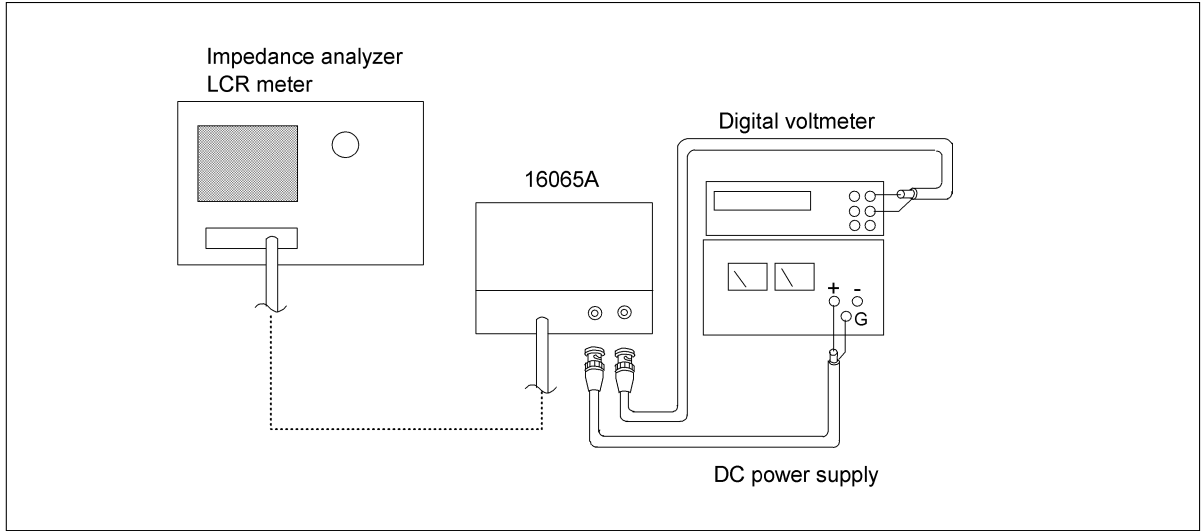


Figure 5-40. External DC bias measurement setup

External DC voltage bias protection in 4TP configuration

If the measurement frequency is above 2 MHz or the type of DUT is not suitable for these external bias fixtures, it is recommended to use the protective circuit shown in Figure 5-41. This circuit is usable with bias voltage up to ± 200 V. To reduce the effects of this additional circuit, perform the open/short compensation with no bias voltage applied.

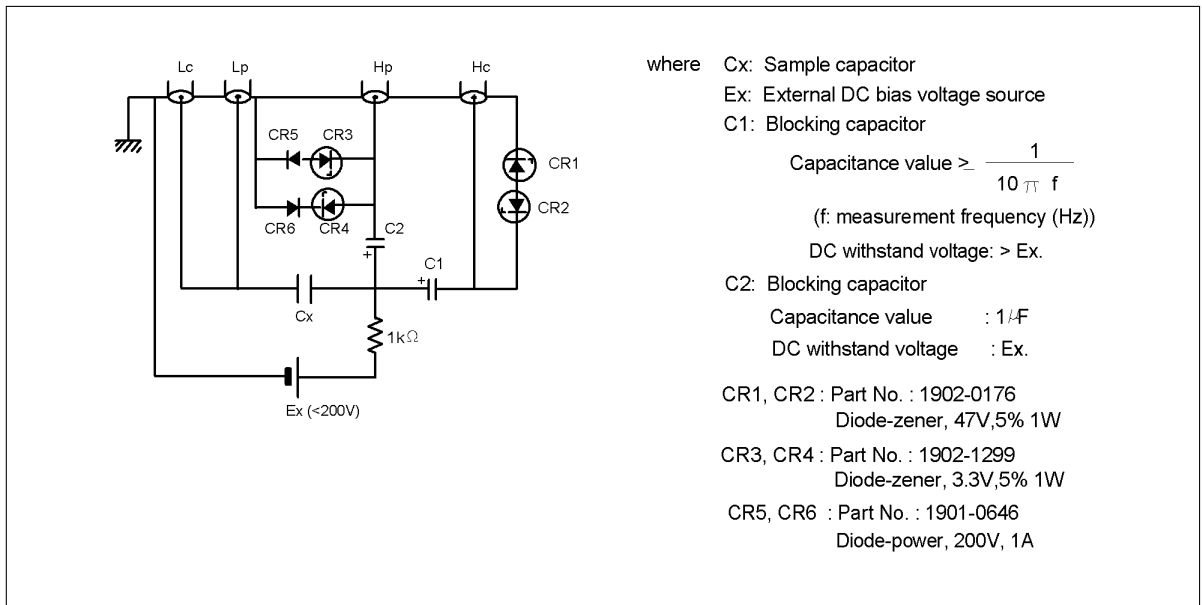


Figure 5-41. External DC voltage bias protection circuit

5-14. DC bias current enhancement

DC current biasing is used for inductor and transformer measurement. In low frequency region, the 4284A precision LCR meter with the 42841A bias current source is suitable for this application because it can apply up to 20 A of bias current. (This can be extended up to 40 A if two 42841As are connected in parallel.)

To deliver a bias current in RF impedance measurement, the 16200B external DC bias adapter can be used with the RF I-V measurement instrument. The 16200B allows you to supply a bias current of up to 5 A across the DUT by using an external DC current source. The 16200B is directly attached to the 7 mm test port and, the test fixture onto the 16200B as shown in Figure 5-42. To minimize the bias adapter induced errors, perform open/short/load calibration at the test fixture terminals with no bias voltage/current applied.

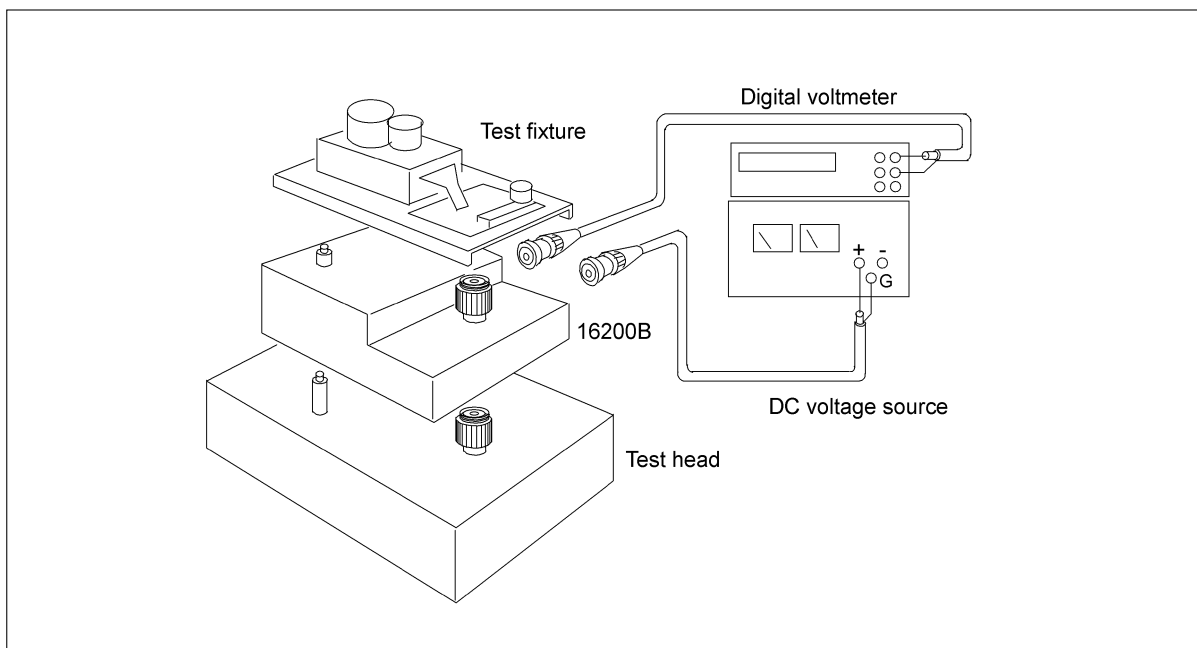


Figure 5-42. External DC bias measurement using the RF I-V measurement instrument

External current bias circuit in 4TP configuration

For external current bias measurement using other auto balancing bridge instruments, an external DC current source and a protection circuit are required. The following describes a protection circuit that can be used for DC bias current measurements up to 10 A. Figure 5-43 shows the protection circuit schematic diagram.

Take caution of electrical shock hazards when using the external DC bias circuit.

A large energy is charged in L1 and L2 as well as the DUT (Lx) by a bias current delivered from an external power supply and, when the DUT is disconnected from the measurement circuit, the DUT generates a very high spike voltage (kick-back voltage) to discharge the energy. To ensure operator safety, decrease the bias current to zero before disconnecting the DUT.

L1 and L2 discharge through the protection circuit the instant the DUT is disconnected from the measurement circuit or the bias current is turned off. To prevent the instrument from being damaged by harmful discharge, the protection circuit must be designed carefully for the withstanding voltage/current rating of each circuit component. Refer to Application Note 346 “A Guideline for Designing External DC Bias Circuit” for more information.

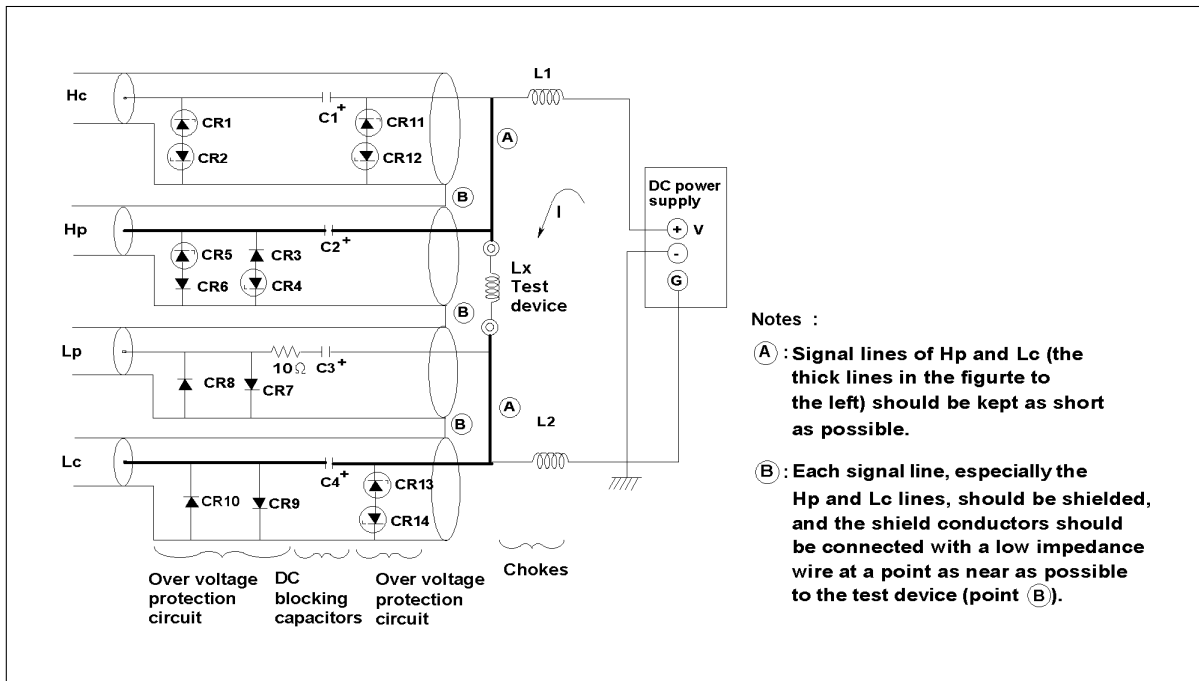


Figure 5-43. External current bias protection circuit

5-15. Equivalent circuit analysis and its application

Agilent's impedance analyzers are equipped with an equivalent circuit analysis function. The purpose of this function is to model the various kinds of components as three- or four-element circuits. The values of the component's main elements and the dominant residuals can be individually determined with this function.

Many impedance measurement instruments can measure the real (resistive) and the imaginary (inductive or capacitive reactance) components of impedance in both the series and parallel modes. This models the component as a two-element circuit. The equivalent circuit analysis function enhances this to apply to a three- or four-element circuit model using the component's frequency response characteristics. It can also simulate the frequency response curve when the values of the three- or four-element circuit are input.

Impedance measurement at only one frequency is enough to determine the values of each element in a two-element circuit. For three- or four-element circuits, however, impedance measurements at multiple frequencies are necessary. This is because three (four) equations must be set up to obtain three (four) unknown values. Since two equations are set up using one frequency (for the real and imaginary), one more frequency is necessary for one or two more unknowns. The equivalent circuit analysis function automatically selects two frequencies where the maximum measurement accuracy is obtained. (This is at the frequency where the $\sqrt{2} \times$ minimum value or $\sqrt{2} \times$ maximum value is obtained). If the equivalent circuit model (described later) is properly selected, accuracy for obtained values of a three- or four-element circuit is comparable to the measurement accuracy of the instrument.

The equivalent circuit analysis function has five circuit modes as shown in Figure 5-44, which also lists their applications. The following procedure describes how to use the equivalent circuit analysis function.

1. Perform a swept frequency measurement for the unknown DUT using the $|Z|-\theta$ or $|Y|-\theta$ function. The sweep mode can be either linear or logarithmic.
2. Observe the frequency response curve. See the typical frequency response curve given in Figure 5-44. Choose the circuit mode that is most similar to the measured curve.
3. Calculate the equivalent parameters by pressing the "Calculate Parameter" key (or the key with the same function.) Three or four values for selected circuit mode are calculated and displayed.
4. Check the simulated frequency response curve. The simulated curve is calculated from the obtained equivalent parameters. If the fitting quality between the simulated curve and the actual measurement results is high, the proper circuit mode was selected. If not, try one of other circuit modes.

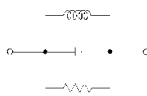
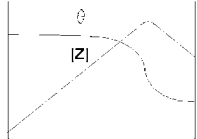
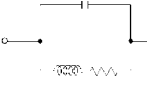
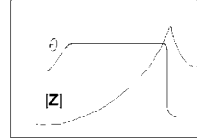
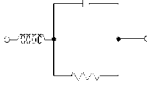
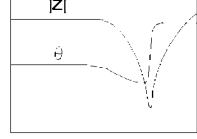
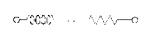
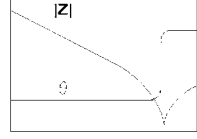
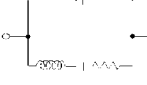
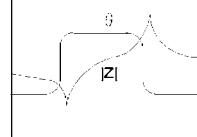
Equivalent circuit	Type of DUTs	$ Z - \theta$ f-characteristics
A 	<ul style="list-style-type: none"> Coils with high core loss 	
B 	<ul style="list-style-type: none"> Coils in general Resistors 	
C 	<ul style="list-style-type: none"> High-value resistors 	
D 	<ul style="list-style-type: none"> Capacitors 	
E 	<ul style="list-style-type: none"> Resonators (crystal, ceramic) 	

Figure 5-44. Equivalent circuit models

If the simulated frequency response curve partially fits the measurement results, it can be said that the selected circuit mode is proper only for that part of the frequency range that it fits. Figure 5-45 (a) shows an example measurement for a low value inductor. As shown in Figures 5-45 (b) and (c), the measurement result does not agree with both the simulated curves over the full frequency range. The higher frequency region is well simulated by circuit mode A and the lower frequency region by circuit mode B. In other words, the circuit mode for the inductor is like the circuit mode A at the higher frequencies and like circuit mode B at lower frequencies. At lower frequencies L is the dominant element, circuit mode A describes the response curve best. At the higher frequencies L and R are the dominant circuit elements, circuit B describes the response curve best. From these facts, we can determine that the real circuit mode should be the combination of circuit modes A and B, and is like Figure 5-46 (a). Figure 5-46 (b) lists an I-Basic program to simulate the frequency response for the circuit given in Figure 5-46 (a). The value of R_s should be keyed in from the front panel and entered into the internal register, and then calculation is executed to see the simulated curve. In this example, the simulated curve agreed with the actual result as shown in Figure 5-46 (c) when the value of R_s is 1Ω .

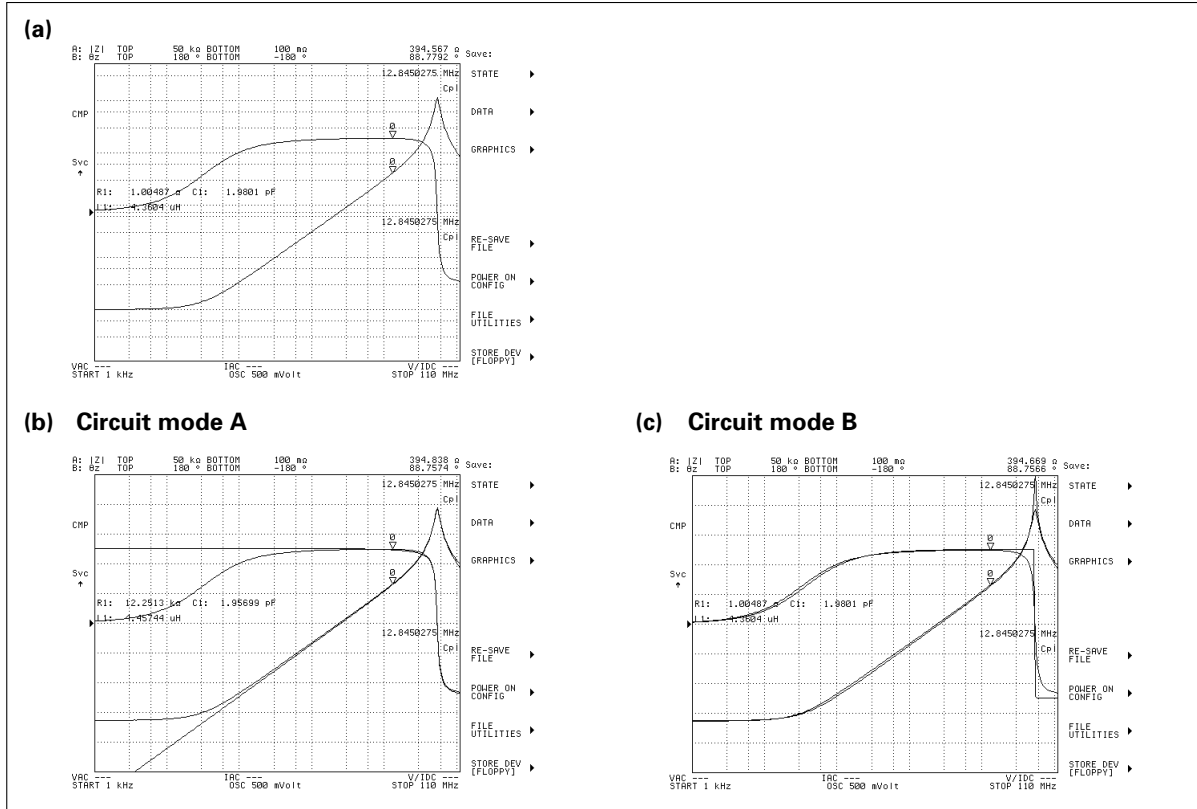


Figure 5-45. Frequency response simulation for a low-value inductor

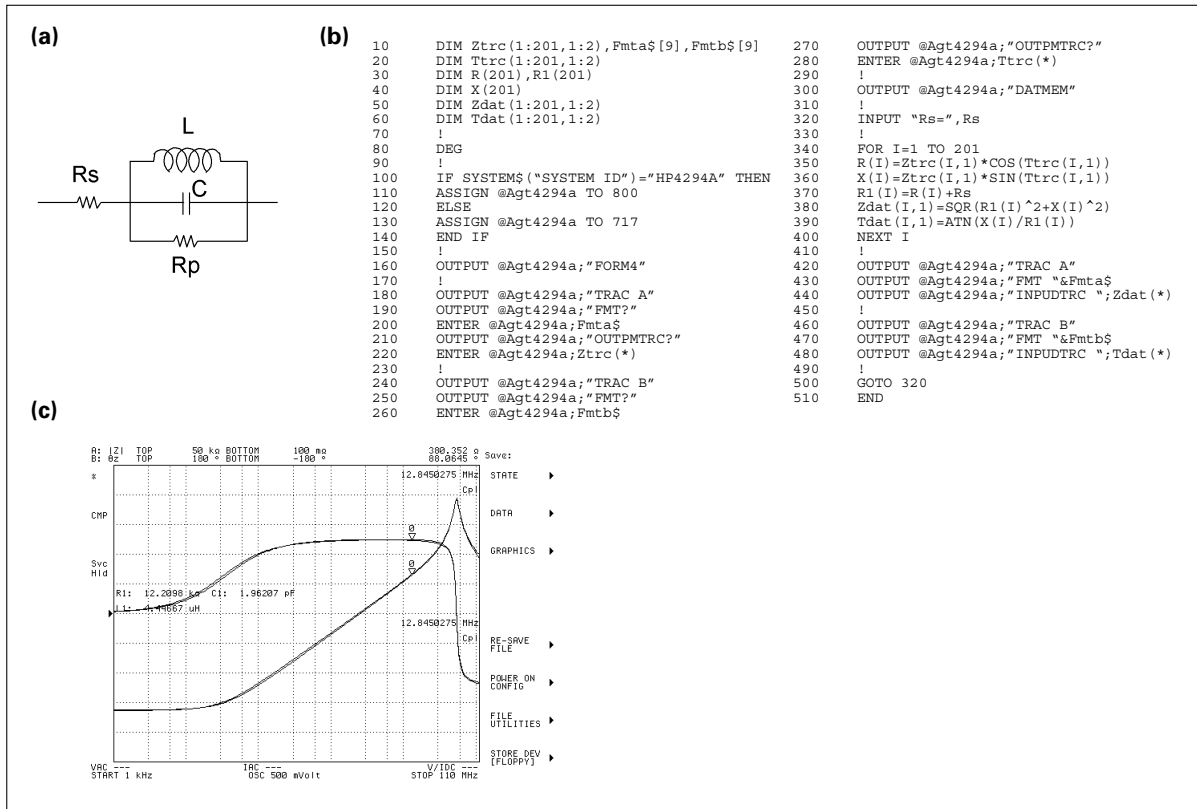


Figure 5-46. Equivalent circuit enhancement

Measurement accuracy can be improved by taking advantage of the equivalent circuit analysis. Figure 5-47 (a) shows an Ls-Q measurement example for an inductor. In this example, an impedance analyzer measures the Q value at 10 MHz. Measured data read by MARKER is Ls=4.78 μ H and Q=49.6. The Q measurement accuracy for this impedance at 10 MHz is calculated from the instrument's specified D measurement accuracy of ± 0.011 , and the true Q value will be between 32 and 109. The reason that the uncertainty of the Q value is so high is that the small resistive component relative to reactance cannot be measured accurately. It is possible to measure the resistive component accurately if the inductive component is canceled by the capacitance connected in series with the inductor. When a loss-less capacitor of $1/(\omega^2L)=53$ pF is connected, the inductor will resonate at 10 MHz. (In this example, a 46 pF capacitor is used for resonance.) Figure 5-47 (b) shows the $|Z|$ - θ measurement results when a 46 pF capacitor is connected. This result can be modeled using circuit mode D, and the value of R is calculated to be 8.51 Ω . The value of L is obtained as 4.93 μ H. Since the equivalent circuit analysis function uses approximately $8.51 \times \sqrt{2} \Omega$ data to calculate the R value, the specified measurement accuracy for a 12 Ω resistance measurement can be used and is $\pm 1.3\%$. Therefore, the Q value can be calculated from $Q=\omega Ls/R=36.4$ with an accuracy of $\pm 2.4\%$ (sum of the L accuracy and R accuracy.) In this measurement, capacitance value does not have to be exactly the calculated value but the loss of the capacitor should be very small because it will affect the calculated Q value.

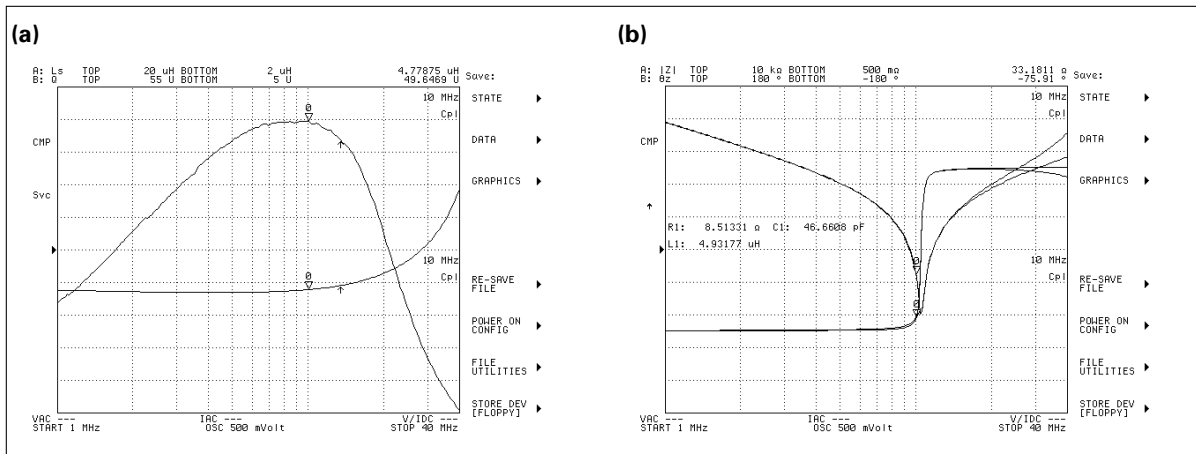


Figure 5-47. Q measurement accuracy improvement

This page intentionally left blank.

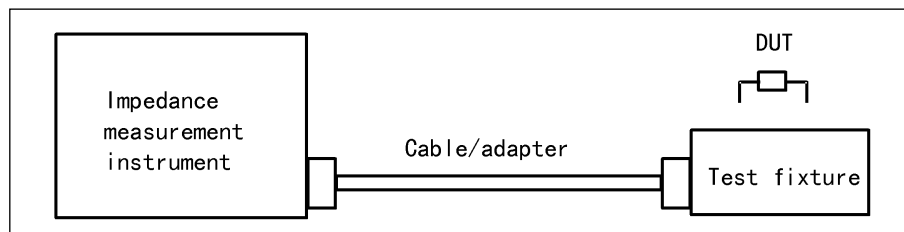
APPENDIX A

The concept of a test fixture's additional error

1. System configuration for impedance measurement

Very often, the system configured for impedance measurements utilizes the following components (See figure below as well).

1. Impedance measurement instrument
2. Cables and adapter interfaces
3. Test fixture



System configuration for impedance measurement

The Impedance measurement instrument's characteristic measurement accuracy is defined at the measurement port of the instrument. This means that the accuracy at the measurement port has traceability and the measurement values are guaranteed.

In an actual measurement, there can be an extension of the measurement port with a cable or an adapter conversion to match the test fixture's terminal configuration. For this reason, cables and conversion adapters are provided for connectivity with the measurement port. These cables (and adapters) are designed with the intent to maintain high accuracy of the measurement instrument while extending the measurement port. Most of the time, the measurement accuracy of the instrument and the cable (or adapter) are specified together as a whole.

A test fixture is an accessory used to connect the DUT to the measurement instrument. Many test fixtures are provided to adapt to various shapes and sizes. It is either connected directly to the measurement port of the instrument or to the port of the extension cable or conversion adapter as described earlier. Its structure determines the applicable frequency range and signal level. Hence, it is necessary to use the appropriate one for the corresponding measurement conditions. In addition, each test fixture has its own characteristic additional error, which is listed in its operational manual.

2. Measurement system accuracy

The equation for the accuracy of a measurement system is shown below:

$$(\text{Measurement accuracy}) = (\text{Instrument's accuracy}) + (\text{Test fixture's additional error})$$

The measurement instrument's accuracy is determined by an equation with terms, which are dependent on frequency, measured impedance and signal level. By substituting the respective measurement conditions into the equation, the measurement accuracy is calculated. If a cable or a conversion adapter is used, then the specified measurement accuracy is the accuracy of the measurement instrument with the cable or adapter. This combined measurement accuracy is shown in the instrument's operational manual.

The equation for the test fixture's additional error is shown below:

$$Z_e = \pm \{ A + (Z_s/Z_x + Y_o \bullet Z_x) \times 100 \} (\%)$$

$$D_e = Z_e/100 (D \leq 0.1)$$

- Z_e : Additional error for impedance (%)
- D_e : Additional error for dissipation factor
- A : Test fixture's proportional error (%)
- $Z_s/Z_x \times 100$: Short offset error (%)
- $Y_o \bullet Z_x \times 100$: Open offset error (%)
- Z_s : Test fixture's short repeatability (Ω)
- Y_o : Test fixture's open repeatability (S)
- Z_x : Measured impedance value of DUT (Ω)

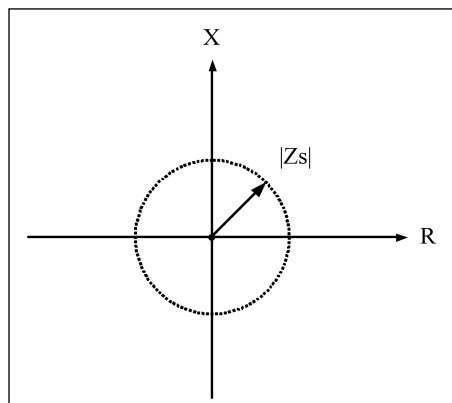
Proportional error, open and short repeatability are mentioned in the test fixture's operational manual and in the accessory guide. By inputting the measurement impedance and frequency (proportional error, open and short repeatability are usually a function of frequency) into the above equation, the fixture's additional error can be calculated.

Proportional error:

The term, proportional error (A), was derived from the error factor, which causes the absolute impedance error to be proportional to the impedance being measured. If only the first term is taken out of the above equation and multiplied by Z_x , then $\Delta Z = A \bullet Z_x$ (Ω). This means that the absolute value of the impedance error will always be A times the measured impedance. The largeness of proportional error is dependent upon how complicated the test fixture's construction is. Conceptually, it is dependent upon the stability of each element of the fixture's equivalent circuit model. From previous experience, proportional error is proportional to the frequency squared.

Short offset error:

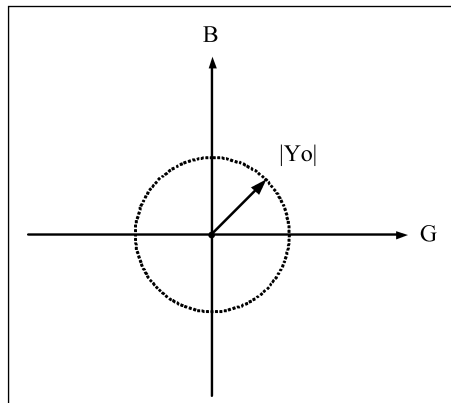
The term, $Z_s/Z_x \times 100$, is called short offset error. If Z_x is multiplied to this term, then $\Delta Z = Z_s$ (Ω). It can be concluded that this term affects the absolute impedance error, by adding an offset. Short repeatability (Z_s) is determined from the variations in multiple measurements of the test fixture in short condition. After performing short compensation, the measured values of the short condition will distribute around 0 in the complex impedance plane. The maximum value of the impedance vector is defined as short repeatability. This is shown in the figure below. The larger short repeatability is the more difficult it is to measure small impedance values. For example, if the test fixture's short repeatability is 100 m Ω , then the additional error of an impedance measurement under 100 m Ω will be more than 100 %. In essence, short repeatability is made up of a resistance and an inductance part, which become larger as the frequency becomes higher.



Definition of short repeatability

Open offset error:

The term, $Y_o \cdot Z_x \times 100$ is called open offset error. If the same analysis is carried out with admittance, then it can be concluded that this term also affects the absolute admittance error, by adding an offset. Open repeatability (Y_o) is determined from the variations in multiple measurements of the test fixture in open condition. As shown in the figure below, the maximum value of the admittance vector in the complex admittance plane is defined as open repeatability. The larger open repeatability is, the more difficult it is to measure large impedance values. Open repeatability is made up of a resistance and a capacitance part, which become larger as the frequency becomes higher.



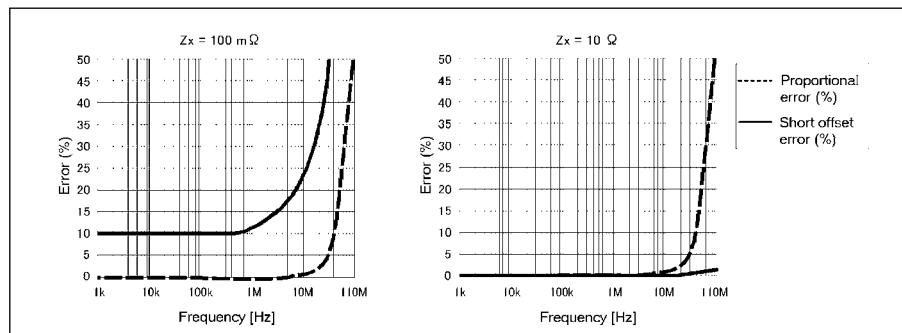
Definition of open repeatability

3. New market trends and the additional error for test fixtures

New devices:

Recently, the debut of extremely low ESR capacitors and the trend to use capacitors at much higher frequencies, have made low impedance measurements more strongly demanded than in the past. As a result, the test fixture's short repeatability has become increasingly important. In the figure below, the relationship between proportional error, short offset error and frequency are shown when measuring low impedance. Notice that when the measured impedance is less than 100 mΩ, short offset error influences the entirety of the test fixture's additional error. As shown in the figure below, when the DUT's impedance is 100 mΩ and the test fixture's short repeatability is 10 mΩ, the short offset error will be 10%. Since the proportional error is minimal in low frequencies, the additional error will be 10% as well.

For the additional error of test fixtures, up until now, it was common to just specify the proportional error (A). As shown in the 10 Ω measurement case (same figure down below), if the measured impedance is large in comparison to the test fixture's short repeatability, then short offset error can be ignored completely. This is the reason why open and short offset error was not specified previously. Test fixtures that are only specified with proportional error are due to this reason. On the contrary, for measured impedance from 1 Ω to 10 kΩ proportional error (A) alone is sufficient to express the test fixture's additional error.

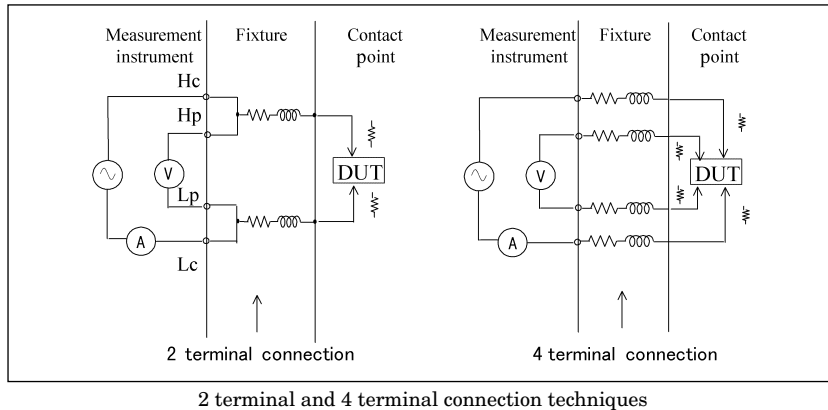


Relationship between proportional error, short offset error and frequency when measuring low impedance

Terminal connection method:

In order to make short repeatability small, there are test fixtures which utilize the 4-terminal connection method (for example 16044A). By employing this technique, the effect of contact resistance is reduced and short repeatability is drastically improved. As a result, the range of accurate low impedance measurements is vastly expanded.

In the figure below, the difference between the 2-terminal connection and the 4-terminal connection is shown. In a 2-terminal connection, the contact resistance, which exists between the fixture's contact and the DUT, is measured together with the DUT's impedance. Contact resistance cannot be eliminated by compensation because the value changes each time the DUT is contacted.



In a 4-terminal connection, the voltage and current terminals are separate. Since the input impedance of the voltmeter is large, no current flows to the voltage terminals. Hence, the voltage that is applied across the DUT can be accurately detected without being affected by the contact resistance. Also, the current that flows through the DUT flows directly into the current terminal and is accurately detected without being affected by the contact resistance. Due to the reasons stated above, it is possible to eliminate the effect of contact resistance and realize a small short repeatability.

Test fixture's adaptability for a particular measurement:

In order to make use of what has been discussed previously, the test fixture's adaptability for a particular measurement will be focused upon. To see whether a test fixture is adaptable, it is important to think about the test fixture's additional error (proportional error, short and open repeatability), measurement impedance and the test frequency range.

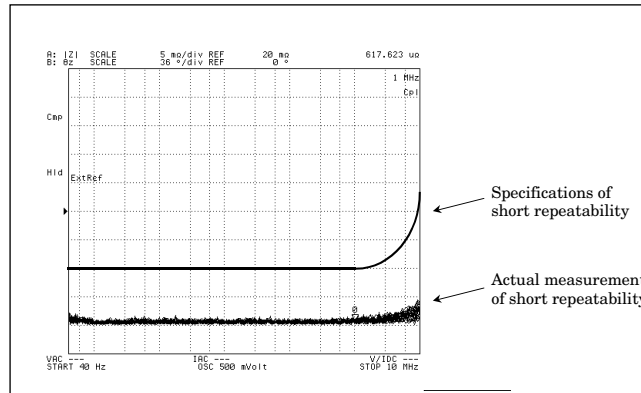
If the measurement impedance is in the 1 to 10 k Ω range, use only proportional error to calculate the additional error of the test fixture. It is fine to assume that this is a close approximation to the fixture's additional error.

If the measurement impedance is not in this range, use proportional error, short and open offset errors to calculate the test fixture's additional error. Recent test fixtures have all three terms specified in their operational manual, so use these values for the calculation.

Some of the recent test fixtures (16044A), due to their structure, have different performance characteristics with different measurement instruments. For these test fixtures refer to their operational manual for more details about the specifications.

So, how are test fixtures, which are not specified with short and open repeatability, assessed whether they are adaptable or not? This assessment is made possible by using the following method to approximate short and open repeatability. To measure a test fixture's short repeatability, measure the impedance of the short condition after performing short compensation. Take the shorting plate out of the fixture and then insert it back in. Measure the short condition again. By repeating this process at least 50 times, it will show the variations in the short condition (See figure below). The final step to determine an approximation of short repeatability is to add a margin

to the values obtained. For open repeatability, measure the admittance of the test fixture's open condition. In the same way, determine open repeatability by measuring at least 50 times.



Measurement of short repeatability (16034G)

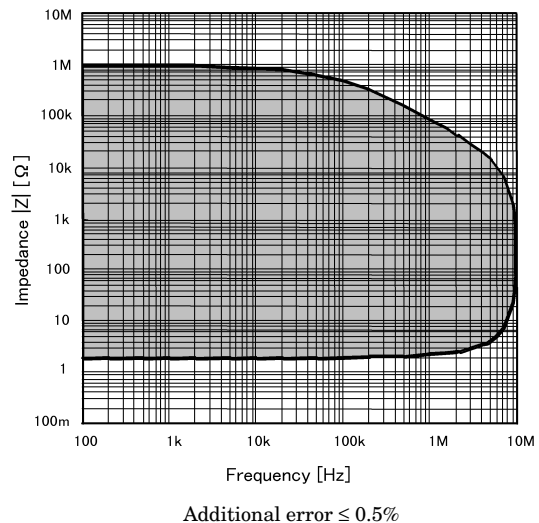
Measurement settings

- Measurement instrument : 4294A
- Measurement frequency : 40 Hz-10 MHz
- Measurement parameter : Z-θ
- Compensation : Performed short compensation
- Bandwidth : 3
- Measurement method : Inserted the shorting plate, measured the short condition, and then removed the shorting plate. Repeated this for 50 times.
- Display method : Overlaying traces by using the accumulate mode

Lastly of all, a method to visually analyze the accurate measurement range of a test fixture is introduced. This method is only appropriate when all three error-terms (proportional error, open and short repeatability) are known. The table below shows the additional error of 16034G. The whole equation, with all three terms can be solved for measurement impedance rather than additional error, for example when additional error is equal to 0.5%. If the obtained impedance values are plotted with measurement impedance (y-axis) against frequency (x-axis), a graph similar to the one shown down below can be obtained. The shaded area shows the range of impedance that can be measured with an additional error better than 0.5%. In the same way, other graphs can be drawn with other additional error values to better visualize the accuracy that can be obtained for a given impedance and frequency range. The operational manuals of recent test fixtures present such graphs.

Additional error of 16034G

Type of error	Impedance
Proportional error	$0.5 \times (f/10)^2$ [%]
Open repeatability	$5 + 500 \times (f/10)$ [nS]
Short repeatability	$10 + 13 \times (f/10)$ [mΩ]



This page intentionally left blank.

APPENDIX B

Open and short compensation

The open/short compensation used in Agilent’s instrument models the residuals as a linear network represented by the ABCD parameters, much like the open/short/load compensation techniques described previously in this document. The difference is that the open/short compensation assumes the unknown network as a “symmetrical network”. From this restriction, the open/short compensation does not require the load measurement to know each value of ABCD parameters. A theoretical explanation and procedure are given in Figure B-1.

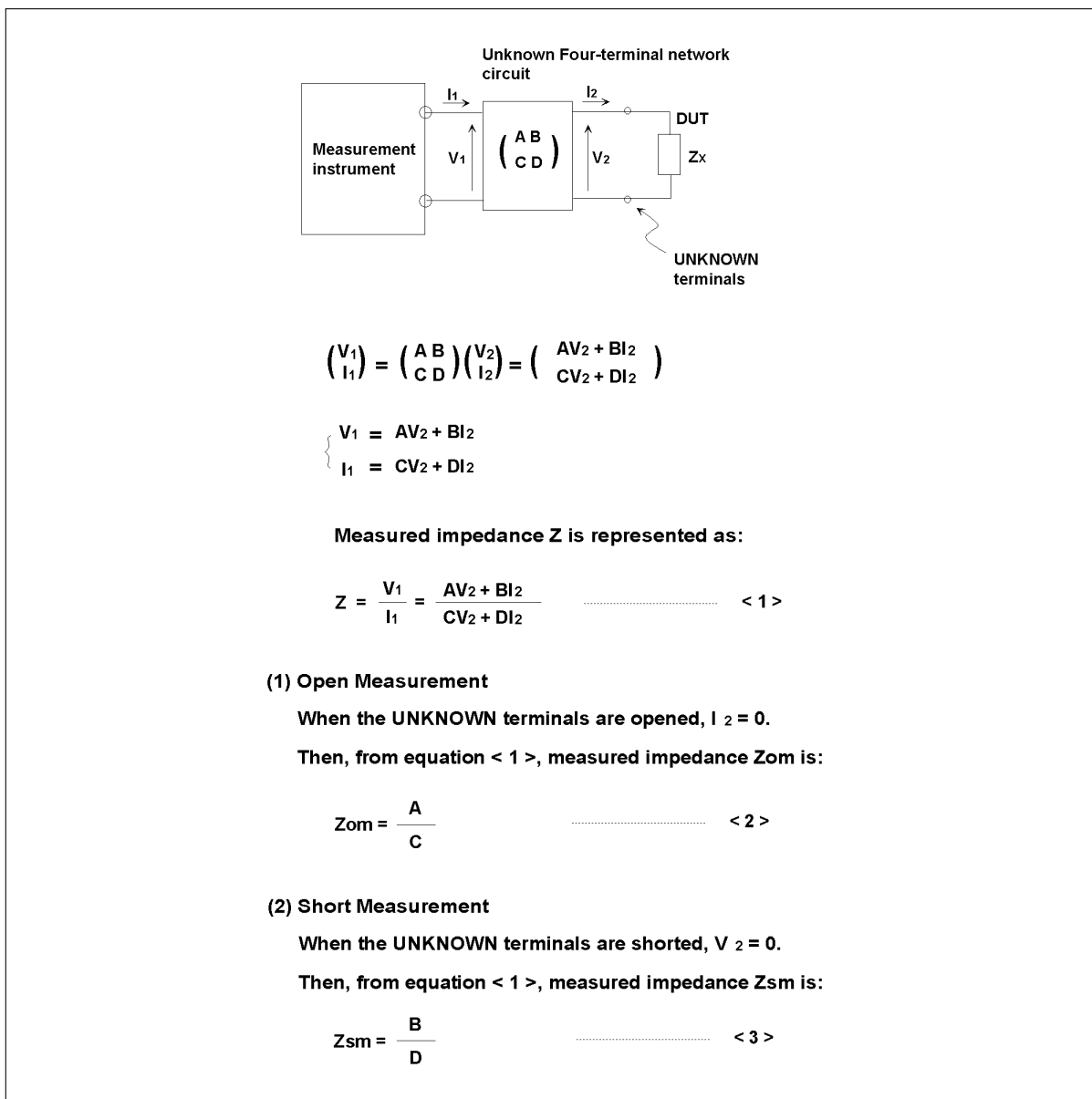


Figure B-1. Open/short compensation (1 of 2)

(3) Limited condition for the ABCD parameters

When the unknown network is "symmetric", following relationship will be found.

$$A = D \quad \dots\dots\dots < 4 >$$

(4) DUT measurement

When the DUT is connected, its impedance value Z_x is represented as :

$$Z_x = \frac{V_2}{I_2} \quad \dots\dots\dots < 5 >$$

From equations < 1 > and < 5 >, its measured impedance value Z_{xm} is :

$$Z_{xm} = \frac{V_1}{I_1} = \frac{AV_2 + BI_2}{CV_2 + DI_2} = \frac{A \frac{V_2}{I_2} + B}{C \frac{V_2}{I_2} + D} = \frac{A Z_x + B}{C Z_x + D}$$

Above equation can be rewritten to give Z_x like :

$$Z_x = \frac{B - D Z_{xm}}{C Z_{xm} - A}$$

From equations < 2 > and < 3 >, A and B are erased :

$$Z_x = \frac{D Z_{sm} - D Z_{xm}}{C Z_{xm} - C Z_{om}} = \frac{D Z_{sm} - Z_{xm}}{C Z_{xm} - Z_{om}} \quad \dots\dots\dots < 6 >$$

From equations < 1 > and < 4 >, unknown parameters C and D in the equation above can be erased.

Then unknown impedance Z_x can be determined by :

$$Z_x = Z_{om} \frac{Z_{sm} - Z_{xm}}{Z_{xm} - Z_{om}}$$

where: Z_{om} : Measured Open impedance

Z_{sm} : Measured Short impedance

Z_{xm} : Measured unknown impedance

Note: All values are complex (vector).

Figure B-1. Open/short compensation (2 of 2)

APPENDIX C

Open, short and load compensation

The open/short/load compensation requires the measurement data of a standard DUT with known values in addition to the open/short measurement data. The residuals of a test fixture, cables or an additional circuit can be defined as a four-terminal network (a two-terminal pair network) expressed with A, B, C, D parameters as shown in Figure C-1.

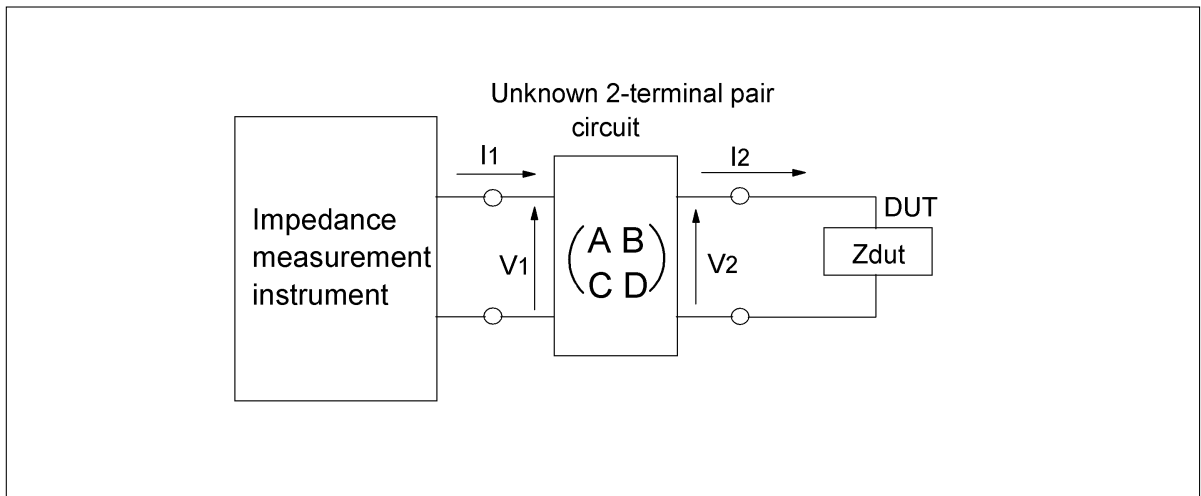


Figure C-1. Open/short/load compensation model

With the assumption that a DUT with impedance of Z_2 is connected to the front panel terminals, the instrument would measure an impedance value of Z_1 . The following relationship defines Z_1 :

Given: $Z_1 = V_1/I_1$ and $Z_2 = V_2/I_2$

$$Z_1 = \frac{AV_2 + BI_2}{CV_2 + DI_2} = \frac{AZ_2 + B}{CZ_2 + D}$$

The parameters of A, B, C and D can be removed when using the following definitions:

- Z_o : Measured value when the instrument terminals are open.
- Z_s : Measured value when the instrument terminals are shorted.
- Z_{sm} : Measured value of the standard DUT when connected to the test setup.
- Z_{std} : True (or expected) value of the standard DUT.
- Z_{xm} : Measured value of DUT.
- Z_{dut} : Corrected value of the DUT.

All of the analysis yields an equation that corrects for impedance error factors:

$$Z_{dut} = \frac{Z_{std} (Z_o - Z_{sm}) (Z_{xm} - Z_s)}{(Z_{sm} - Z_s) (Z_o - Z_{xm})}$$

(Note that each parameter has real and imaginary components.)

This page intentionally left blank.

APPENDIX D

Electrical length compensation

A test port extension can be modeled using a coaxial transmission line as shown in Figure D-1. When an impedance element Z_L is connected to the tip of the line, the measured impedance value Z_i at the other end of the line (that is, test port) is given by the following equation:

$$Z_i = Z_0 \frac{Z_L + Z_0 \tanh \gamma \ell}{Z_L \tanh \gamma \ell + Z_0}$$

$$\gamma = \alpha + j\beta = \sqrt{ZY} = \sqrt{(R+j\omega L)(G+j\omega C)}$$

Where, γ : Propagation constant of the transmission line
 α : Attenuation constant of the transmission line
 β : Phase constant of the transmission line
 ℓ : Transmission line length
 Z_0 : Characteristic impedance of the transmission line

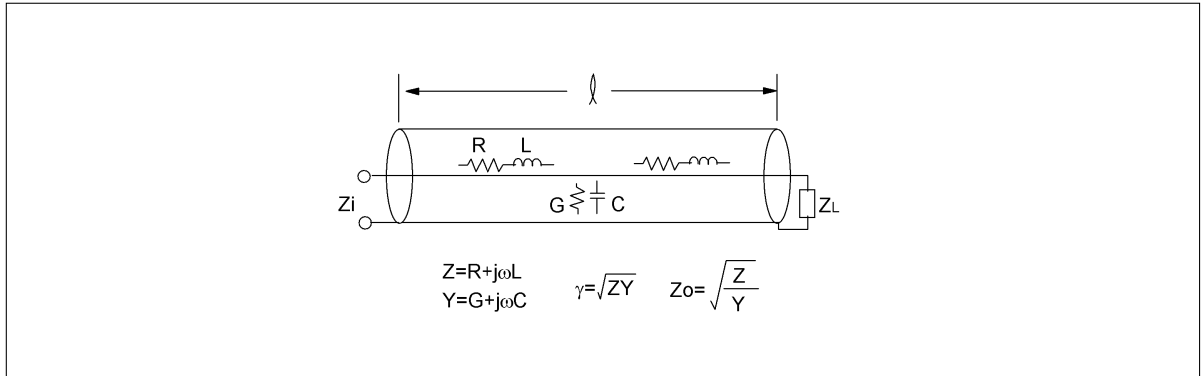


Figure D-1. Transmission line model of test port extension

The DUT impedance value is therefore calculated as:

$$Z_L = Z_0 \frac{Z_0 \tanh \gamma \ell - Z_i}{Z_i \tanh \gamma \ell - Z_0}$$

If the transmission line has no propagation loss ($\alpha=0$, $\beta=\omega\sqrt{LC}$), the equation for Z_L is simplified as follows:

$$Z_L = Z_0 \frac{Z_i - jZ_0 \tan \beta \ell}{Z_0 - jZ_i \tan \beta \ell}$$

The true Z_L value can be calculated if the phase shift quantity, $\beta \ell$, is known. Here, the phase constant β is related to the test signal wavelength λ in the transmission line as follows:

$$\beta = \frac{2\pi}{\lambda}$$

When a (virtual) transmission line in which the signal wavelength is equal to the wavelength in vacuum is assumed, the virtual line length (ℓ_e) that causes the same phase shift ($\beta \ell$) as in the actual line is given by the following equation:

$$\ell_e = \frac{\lambda_0}{\lambda} \ell \quad \left(\text{because } \beta \ell = \frac{2\pi \ell}{\lambda} = \frac{2\pi \ell_e}{\lambda_0} \right)$$

Where, λ_0 : wavelength in vacuum

λ : actual wavelength in transmission line

Therefore, the phase shift quantity, $\beta \ell$, can also be expressed by using the phase constant β_0 in vacuum and the virtual line length ℓ_e (because $\beta \ell = \beta_0 \ell_e$.) Since the β_0 value is derived from physical constants ($\beta_0 = 2\pi/\lambda_0 = \omega/c$, c : velocity of light), it is possible to represent the phase shift by using only the virtual line length ℓ_e .

This virtual line length is specified as the electrical length of the test fixtures and airline extensions. Accordingly, the compensation procedure to derive the impedance Z_L can be simplified by using the electrical length value. In case of the coaxial line, since the β value is proportional to \sqrt{C} (C : distributed capacitance of the line), the electrical length is proportional to the square root of the dielectric constant of the insulation layer between the inner and outer conductors.

APPENDIX E

Q Measurement accuracy calculation

Q measurement accuracy for auto balancing bridge type instruments is not specified directly as $\pm\%$. Q accuracy should be calculated using the following equation giving the possible Q value tolerance.

$$Q_t = \frac{1}{\frac{1}{Q_m} \pm \Delta D}$$

Where: Q_t is the possible Q value tolerance
 Q_m is measured Q value
 ΔD is D measurement accuracy

For example, when the unknown device is measured by an instrument which has D measurement accuracy of .001, and the displayed Q value is 200, the Q tolerance is calculated as:

$$Q_t = \frac{1}{\frac{1}{200} \pm .001} = \frac{1}{.005 \pm .001}$$

This result means that the true Q value will be between 167 and 250.

Note: The following equation may be used to calculate the Q value tolerance. (The result is the same as that from the above equation.)

$$Q_t = \pm \frac{Q_m^2 \times \Delta D}{1 \mp (Q_m \times \Delta D)}$$

This page intentionally left blank.

This page intentionally left blank.

For more assistance with your test & measurement needs go to

www.agilent.com/find/assist

Or contact the test and measurement experts at
Agilent Technologies
(During normal business hours)

United States:
(tel) 1 800 452 4844

Canada:
(tel) 1 877 894 4414
(fax) (905) 206 4120

Europe:
(tel) (31 20) 547 2000

Japan:
(tel) (81) 426 56 7832
(fax) (81) 426 56 7840

Latin America:
(tel) (305) 267 4245
(fax) (305) 267 4286

Australia:
(tel) 1 800 629 485
(fax) (61 3) 9272 0749

New Zealand:
(tel) 0 800 738 378
(fax) 64 4 495 8950

Asia Pacific:
(tel) (852) 3197 7777
(fax) (852) 2506 9284

Product specifications and descriptions in this document subject to change without notice.

Copyright © 2000 Agilent Technologies
Printed in USA December 17, 2003
5950-3000